



Wayfinding/Signage Design Criteria Manual

Wayfinding Design Standards	1.01	Facilities Signage	4.01	Appendix	6.01
Guiding Principles	1.01	General Information	4.01		
Signage Design Guide	1.02	Facilities Wayfinding Signage	4.02	Signage Location Plans and Message Schedule	6.01
		Campus Signage Standards	5.01	Research Report	6.24
Landside Signage Standards	2.01	General Information	5.01	Existing Conditions Analysis	6.24
General Information	2.01	Standards & Regulations	5.03	Passenger Behavior Analysis	6.28
Landside Wayfinding Signage	2.02	Temporary Signage Standards	5.04	Sense of Place Analysis	6.41
		Building Mounted Signage	5.06		
Terminal Signage Standards	3.01	Free-Standing Signage	5.08		
General Information	3.01				
Standards & Regulations	3.04				
Terminal Wayfinding Signage	3.06				
Temporary Signage Standards	3.33				

Wayfinding Design Standards

Guiding Principles

Signage plays a vital and pervasive role in how we navigate and experience our built environment. When approached with creativity and intension, wayfinding becomes more than just directional – it invites deeper engagement and a more curious exploration of place. Its symbology also serves as a strategic branding tool, creating a distinctive and memorable connection not just between two points, but between Ontario and its passengers.

Effective and compelling signage strikes a delicate balance between standing out and blending in. Often, simplicity is the most powerful approach – especially when planning messages that guide wayfinding. Thoughtful, logical strategies help ensure signage remains clear and intuitive, even when navigating complex environments feels overwhelming.

EASE AND SIMPLICITY

Ontario International Airport is uniquely positioned to offer convenience and experience for its passengers. It is So Cal, So Easy. The signage and wayfinding system needs to reflect this ease and simplicity.

EMBRACE THE REGION

Ontario is in a vibrant, growing area of Southern California. The airport anchors the Inland Empire and serves as a vital transportation hub for the surrounding region. As we look forward to the future of both the region and the airport, a symbiotic relationship is critical to empower both to reach full potential.

RESPECT THE BRAND

While your wayfinding package won't be limited to this, all options will acknowledge and celebrate your current brand.

ESTABLISH AN IDENTITY

Integrating ease and simplicity, while embracing the region and respecting the brand, will help establish a strong and lasting identity. This identity will carry ONT and the surrounding region into the future, therefore the solution must be thoughtful and applied consistently and in alignment with the wayfinding strategies.

BE INNOVATIVE, BUT NOT COMPLICATED

As technology solutions emerge, it is important to keep ONT's signage and wayfinding program innovative, but not complicated. Ease and simplicity is the driving principle when it comes to technology solutions. Passengers have come to expect this from ONT, and it is our responsibility to deliver.

Signage Design Guide

The design put forward carefully considers each of the Guiding Principles created through the feedback and in-depth knowledge shared during the visioning and sense of place listening sessions with the Airport and City audience. Through use of each of these principles as a defining strategy, a versatile and iconic wayfinding language specific to ONT, with timeless styling, and adaptability that will allow it to enhance with future city and airport growth has been created. The intentional and signature design moves described below achieve this in a way that relates to region and branding and creates a finished product the Airport is proud to call its own.

EASE AND SIMPLICITY

The ease and simplicity of the airport experience as well as the lifestyle in Ontario is a repeated theme. This translates into the signage through clear hierarchical messaging with a crisp and non-ornamental fashion focused on guidance and clarity. The stark solid blue with contrasting white font calls to a formality and familiarity of top ranked international airports throughout the United States and situates ONT as a front runner in its own right.

EMBRACE THE REGION

A subtle nod to the geography of the region exists in a design move described as ‘the ascent.’ Beautifully stacked materials create the thickness of the sign, with the blue outermost plate’s rectilinear profile sweeping upward in a simple gesture created by two radii, splitting the sign band distinctly into a steely gray arc and a blue sky that traces it. This action within the sign divides in to create opportunities for hierarchy in messaging and room for a ribbon of cerulean blue light to graze down on to the steel portion below.

RESPECT THE BRAND

The wayfinding package carefully takes note of all items that have been previously and considerately woven into the ONT brand and celebrates them rather than trying to reinvent. Signage primarily exists as the dark blue color from the ONT logo and branding, which offers a high contrast back drop to the white messaging applied to it, sure to stand out and call attention.

ESTABLISH AN IDENTITY

Through considerate usage of a single design move, the ONT wayfinding design lends itself towards an iconic identity that will resonate with passengers and guests each time they see it, subconsciously binding itself with the campus in a way that continuously reminds them of where they are without continual need of the ONT logo.

BE INNOVATIVE, BUT NOT COMPLICATED

The ONT wayfinding strategy celebrates a unique identity without creating a need for monitoring digital content or relying on technology that can be dated. Through a simple celebration of materiality, lighting, and a singular design move, the ONT wayfinding solution finds a way to heighten the passenger experience with minimal effort, ease, and adaptability intrinsically built in.

ONTARIO

INTERNATIONAL AIRPORT

SIGNAGE DESIGN DRIVERS

The primary purpose of an airport sign system is to move passengers through the airport using a concise and comprehensive system of directional, informational, and regulatory messages. In turn, this will improve passenger experience and create a positive impression of not only the airport, but Ontario and the surrounding region.

In order to provide the vital consistency required to clearly communicate to passengers, it will be important to establish fundamental design elements of ONT's wayfinding strategy. These elements are:

- Terminology and Message Hierarchy
- Ascent
- Typography
- Format and Color
- Symbology



TERMINOLOGY AND MESSAGE HIERARCHY

Consistent wording in all forms of communication is critical to clearly communicating to passengers the intent of a sign across the airport campus. Additionally, placement of messages should be done in such a way as to establish a primary message versus secondary messaging.

Hierarchy also includes prioritizing what information to list at a given decision point in the route. In other words, what is the minimum amount of information necessary to move a passenger to the next decision point? The goal is to avoid information overload.

Primary messaging for ONT should be at the top of the sign and utilize the bold typeface. It should be noted that whenever the term 'Gates' or 'Gate' is used in primary messaging that it will be in regular type face. Secondary messaging should be below and utilize the regular typeface.

EXAMPLES OF PRIMARY MESSAGING HIERARCHY AT THE ROADSIDE

Terminal 2
Airport Exit
Return to Terminals
Lot 2
Rental Cars

EXAMPLES OF SECONDARY MESSAGING HIERARCHY AT THE ROADSIDE

Daily
Hourly

EXAMPLES OF PRIMARY MESSAGING HIERARCHY IN THE TERMINALS

Gates 201 - 206
Gate 201
EXIT

EXAMPLES OF SECONDARY MESSAGING HIERARCHY IN THE TERMINALS

Restrooms
Animal Relief Area
Nursing Room
Restaurants & Shops
Information
Check-In
Baggage Claim
Security Checkpoint
Ground Transportation

THE ASCENT

The ascent is not only a visual representation of the contrail from the plane, but also of the mountainous horizon of the surrounding region. It is smooth to indicate ease and relaxation and moves upward to represent the optimism of flight.

The geometry of the ascent consists of two parallel lines adjoined by a line at a 45 degree angle to the parallel. Underneath the ascent line is either the ONT logo or an up arrow symbol. Adequate, equal spacing should be provided underneath the ascent line and the feature element. The top bar of the ascent should be equal to that of the spacing, while the bottom bar should be half of top bar. The fillet of the upper connection should respond appropriately to the feature element to convey a smooth transition at the top. The fillet radius of the lower connection should be equal to that of the height of the bottom bar.

The ascent line will ultimately house a reveal to allow for light to emit from underneath. This light is used not only as an accent feature but to call back to the ONT brand. The use of the dark and light blue represent night and day and its integration into the ascent feature is an elevation of these particular sign types within the ONT campus.

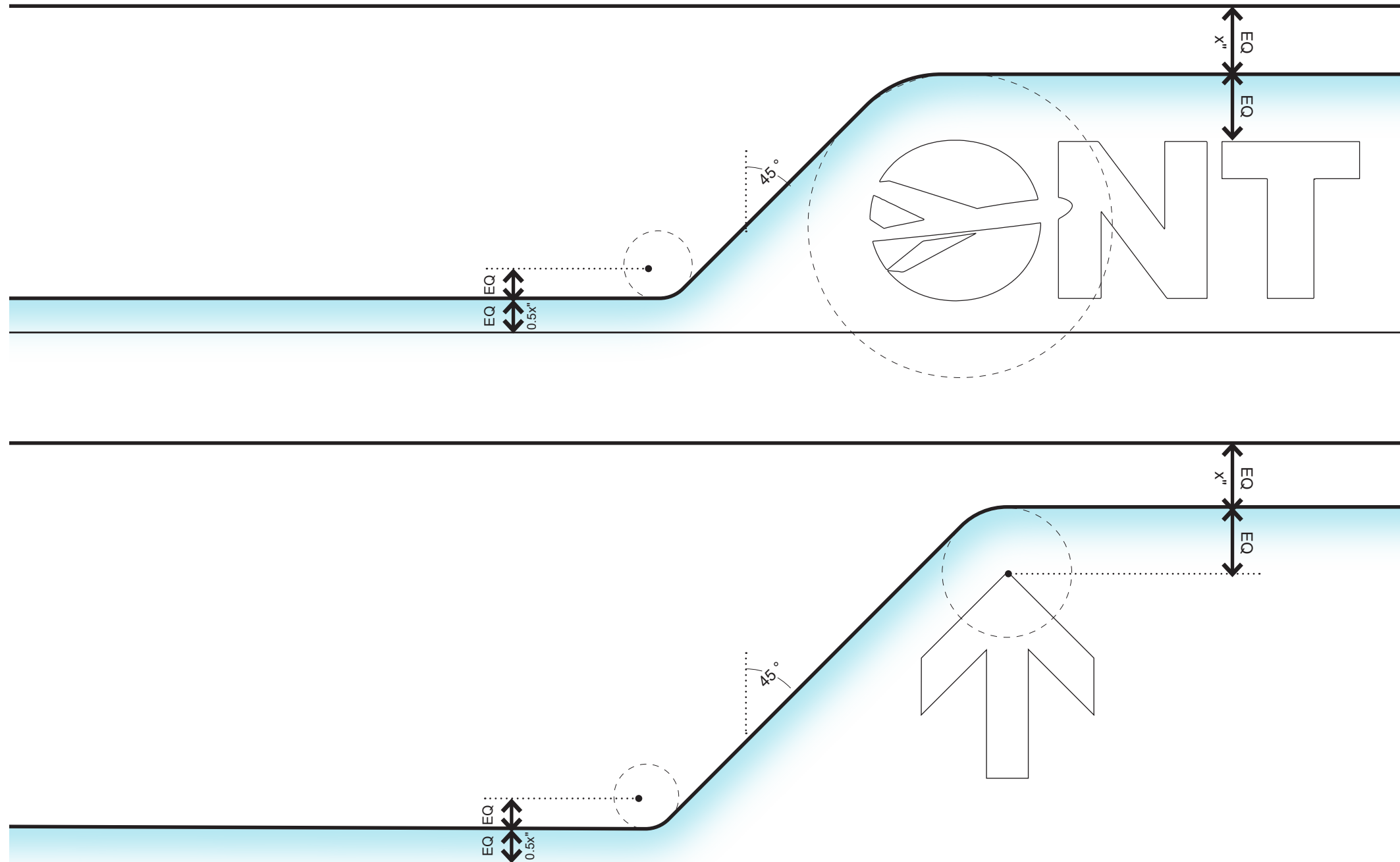

TYPOGRAPHY

The primary signage font is Open Sans. Primary messaging may be bold but should be used conservatively.

Open Sans

ABCDEFGHIJKLMNOPQRSTUVWXYZ
abcdefghijklmnopqrstuvwxyz
1234567890

Open Sans Bold

ABCDEFGHIJKLMNOPQRSTUVWXYZ
abcdefghijklmnopqrstuvwxyz
1234567890

Example Uses

Lot 2
Daily Parking

COLOR

The primary sign color will be the dark blue from the *Ontario International Airport Brand Guide*. The lettering will be white.

When pictograms are used with accompanying text, they are to be enclosed in a rounded white square with the pictogram being dark blue. When pictograms are used as the only element on the sign, they will be white on the dark blue sign. Arrows should always be white and never be enclosed in a rounded square.

Accent lighting is incorporated into the sign to draw attention to the sign. This accent lighting is to match the cerulean blue from the *Ontario International Airport Brand Guide*. Some signage will incorporate a stainless steel accent panel. It should remain unfinished, closely matching ONT cool gray as shown in the signage primary palette.

SIGNAGE PRIMARY PALETTE



PANTONE: 7687 C
CMYK: 76, 53, 0, 45
RGB: 33, 65, 139
HEX: 21418B

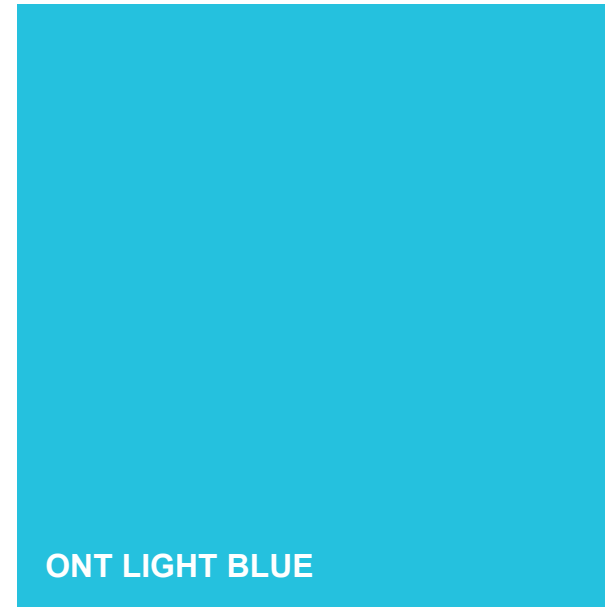

PANTONE: 311 C
CMYK: 83,13, 0, 13
RGB: 37, 193, 222
HEX: 25C1DE



PANTONE: Cool Gray 9C
CMYK: 55 M.47 Y.44 K.11
RGB: 119 G.118 B.121
HEX: 767679

SIGNAGE SUPPORT PALETTE

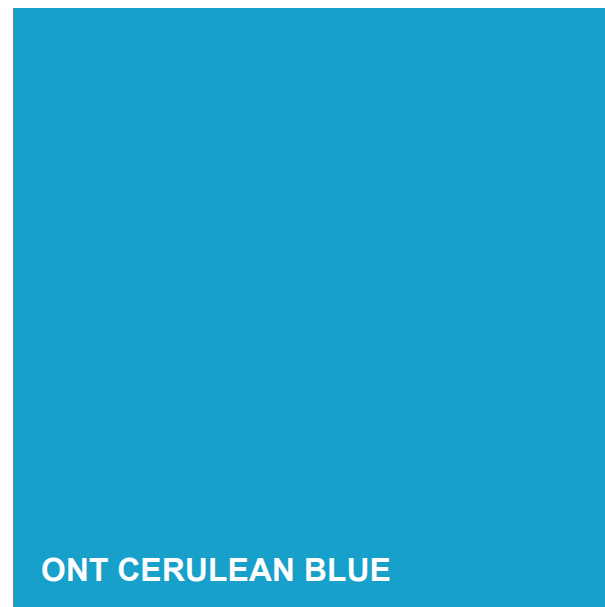

PANTONE: 2200 C
CMYK: 87,20, 0, 21
RGB: 27, 161, 202
HEX: #1BA1CA

SYMBOLGY

Pictograms are the universal vocabulary that can transcend words, languages, locations, and cultures. Symbol design is a critical component of graphic design. While words are the primary conveyors of key information, symbols are often needed to augment and sometimes even replace words. Especially in aviation facilities, symbols identify key destinations or services quickly, regardless of the language understood by the user.

Signage at Ontario International Airport will utilize the symbol family created by the American Institute of Graphic Arts for the U.S. Department of Transportation. This is widely considered the standard for international airports in the United States and should be used for consistency of message.

Pictogram readability is a function of many combined factors including size, view angle, distance, color and background contrast. To ensure pictograms are proportioned appropriately, they will live within a rounded square, where the pictogram extends to fill 70% of the square, maximizing in either height or width of pictogram. The rounded corner will be a fillet of approximately 12.5% the overall width of the square.

Where pictograms are provided as designations of permanent interior rooms and spaces, they shall comply with requirements for minimum field height, finish and contrast, and they shall be accompanied by compliant tactile (raised letter and braille) descriptors. Directional and informational pictograms are not required to have tactile descriptors.

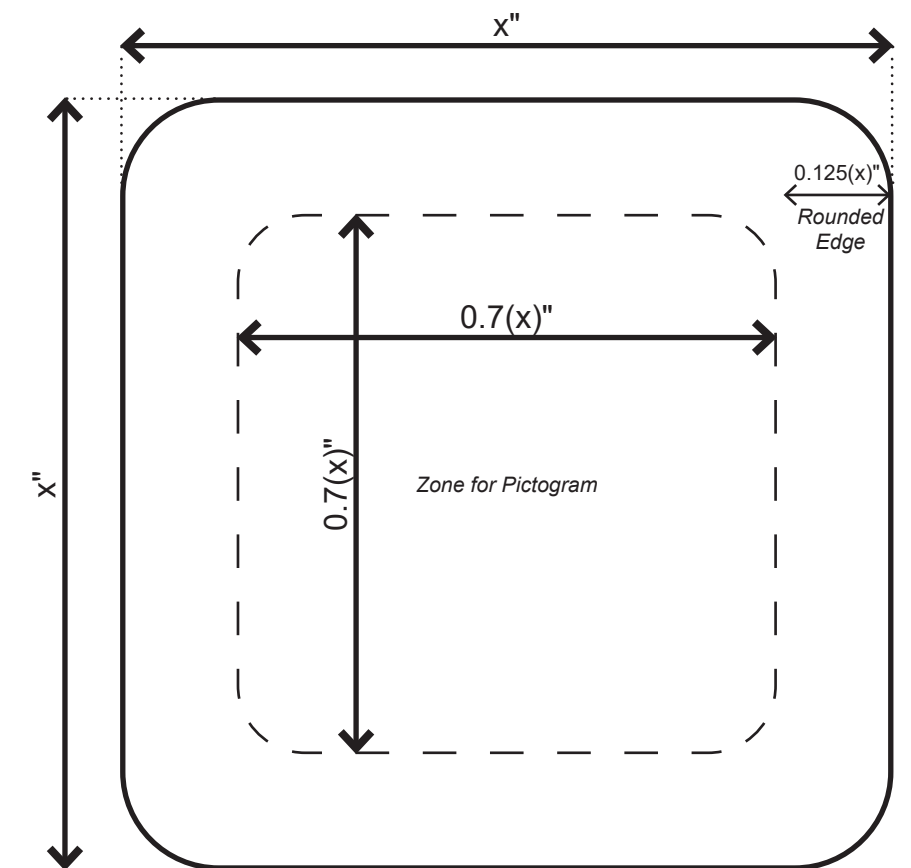

Dimensional Control of the Pictogram













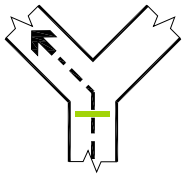

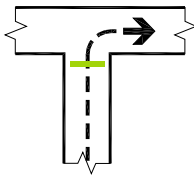



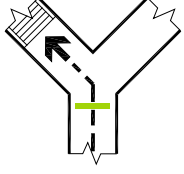

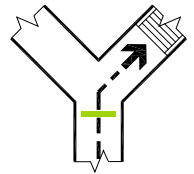
Pictograms

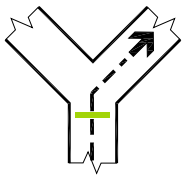

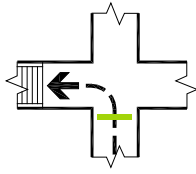
Pictograms

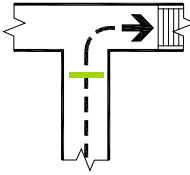

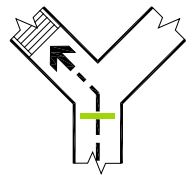
PATHWAYS - ORIENTATION AND INTERPRETATION

Orientation	Location Plan	Interpretation	Orientation	Location Plan	Interpretation	Orientation	Location Plan	Interpretation
		STRAIGHT AHEAD			AHEAD ON LEFT			RIGHT
		UP			UP ON LEFT			DOWN ON RIGHT
					AHEAD ON RIGHT			LEFT
					UP ON RIGHT			DOWN ON LEFT
								DOWN

Landside Signage Standards

General Information

Colors & Fonts

Colors and fonts are limited to the ONT branding only.

Material

Typical sign construction must be painted aluminum or acrylic with applied vinyl, exceptions noted on each sign.

Illumination (internal or external) to be coordinated and field verified according to location.

Code Requirement

All signage to conform to the current sign codes.

Landside Signs

Building Mounted Signage

- Curbside Overhead Signs
- Overhead Portal Signs
- Door Identification Signs

Freestanding Signage

- Pylon Signs
- Post & Panel Signs

Outline of Sign Types

Landside Wayfinding Signage



L-A1 CURBSIDE OVERHEAD SIGN



L-C1 DOOR IDENTIFICATION SIGN



L-B1 OVERHEAD PORTAL SIGN

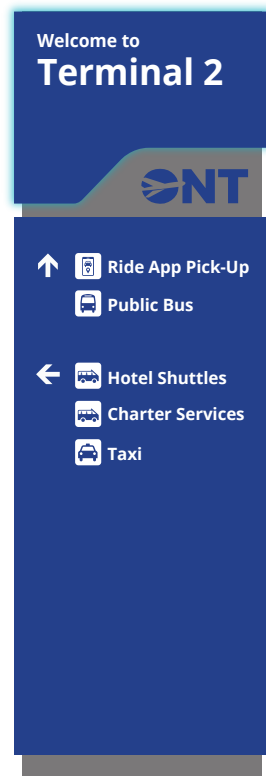

L-D2 FREESTANDING PYLON (SINGLE-SIDED OR DOUBLE SIDED)



L-E1 FREESTANDING PYLON (VERTICAL)



L-E2 LARGE POST & PANEL



L-F1 FREESTANDING PYLON (HORIZONTAL)

L-A1 CURBSIDE OVERHEAD SIGN

Overhead signs to be placed at the curbside, to direct passengers to drop-off and pick-up for departures, arrivals and various ground transportation services.

Construction Notes:

1. Double faced, 2" deep ceiling mounted fabricated aluminum sign with LED accent light and internal framing as required.
2. Sign panel to be painted as noted.
3. Copy and graphics to be reflective vinyl die cut in colors indicated.
4. 1/8" thick painted aluminum gate number/ arrow to be attached on sign panel, fabricator to match existing ONT standards.
5. Designer to field verify and determine best method of installation with minimal visual impact. Fabricator to provide structural engineering calculations as required and coordinate with general contractor for structural requirements.
6. Field verify existing conditions.
7. Vertical supports and bracket with decorative cladding as required. Provide smallest diameter as allowed by structural engineering calculations.

Note: The scale of signage and graphics is subject to change in order to be compliant with ADA guidelines.

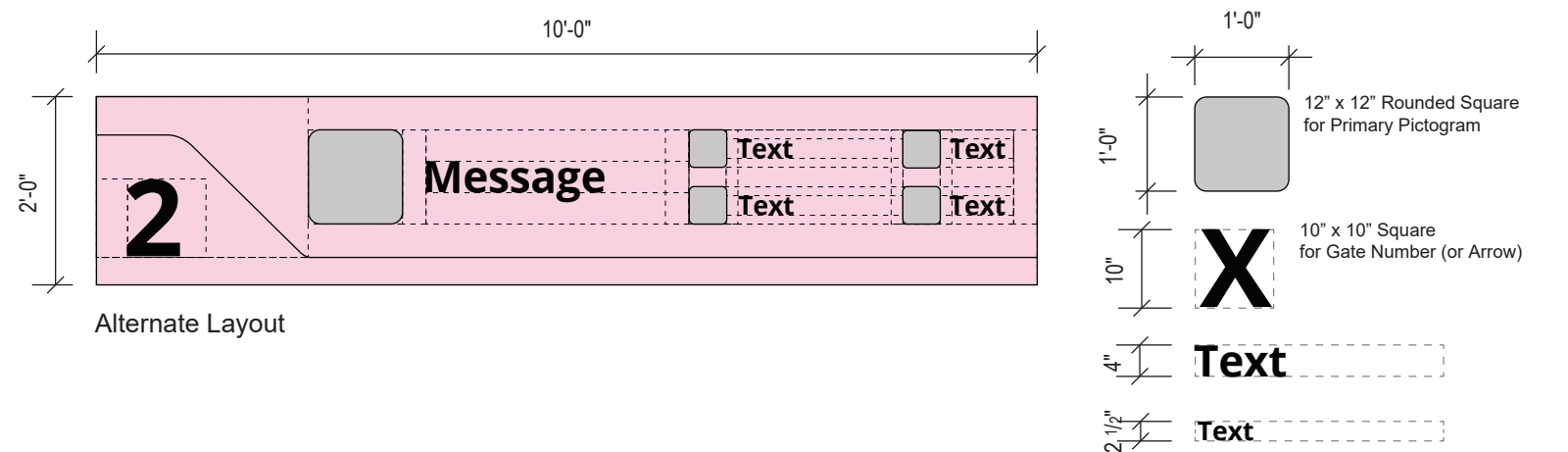
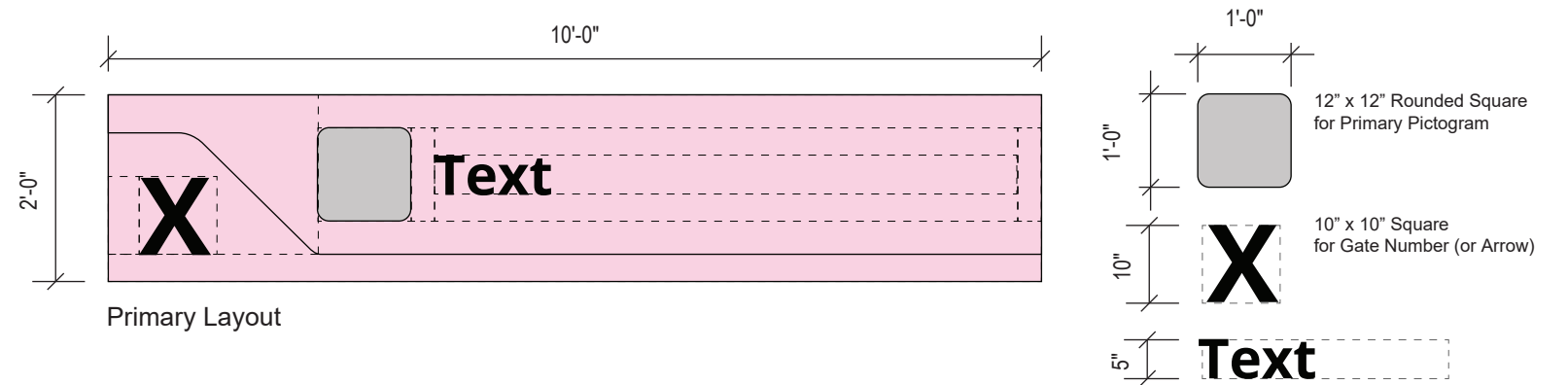
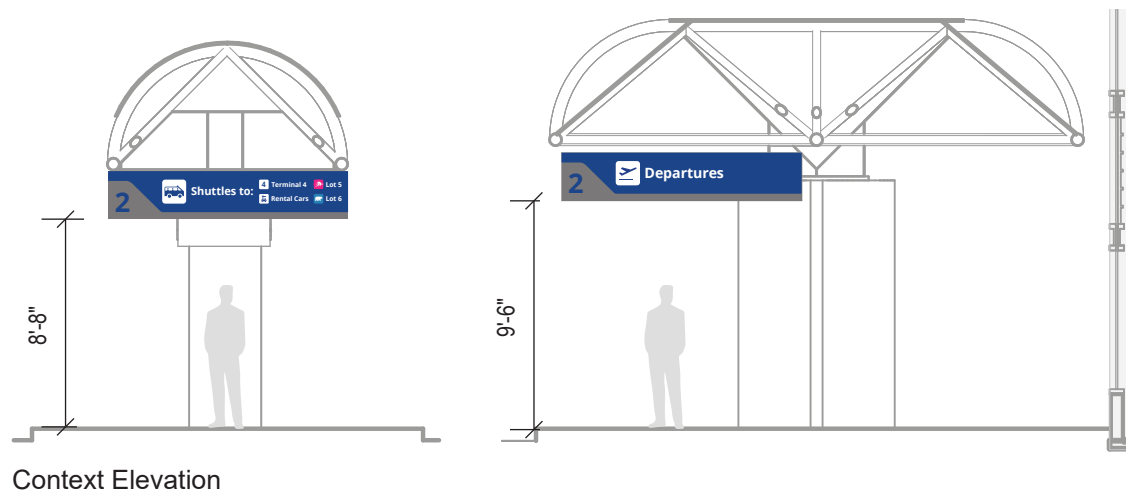

L-A1 CURBSIDE OVERHEAD SIGN



L-A1 - Static Sign
Departures/ Arrivals Curb



L-A1 - Static Sign
Shuttles/ Taxi Median

L-A1 CURBSIDE OVERHEAD SIGN - ALTERNATE

Overhead signs to be placed at the curbside, to direct passengers to drop-off and pick-up for departures, arrivals and various ground transportation services.

Construction Notes:

1. Double faced, ceiling mounted fabricated aluminum sign with LED display and static gate number, internal framing as required.
2. Sign panel to be painted as noted.
3. Static copy and graphics to be reflective vinyl die cut in colors indicated.
4. LED Display specifications to be approved by ONT. Provide manufacturer's requirements for ventilation in sign cabinet. Allow for ease of maintenance with inconspicuous access panels. Depth of signage may vary according to display requirements.
5. Designer to field verify and determine best method of installation with minimal visual impact. Fabricator to provide structural engineering calculations as required and coordinate with general contractor for structural requirements.
6. Field verify existing conditions.
7. Vertical supports and bracket with decorative cladding as required. Provide smallest diameter as allowed by structural engineering calculations.

Note: The scale of signage and graphics is subject to change in order to be compliant with ADA guidelines.

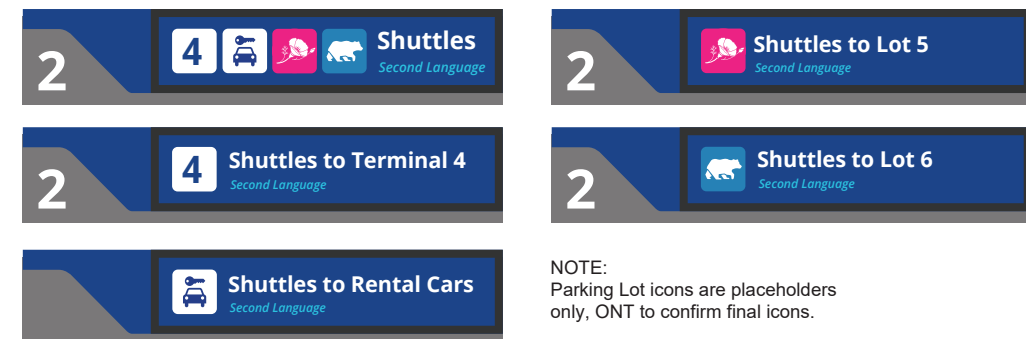
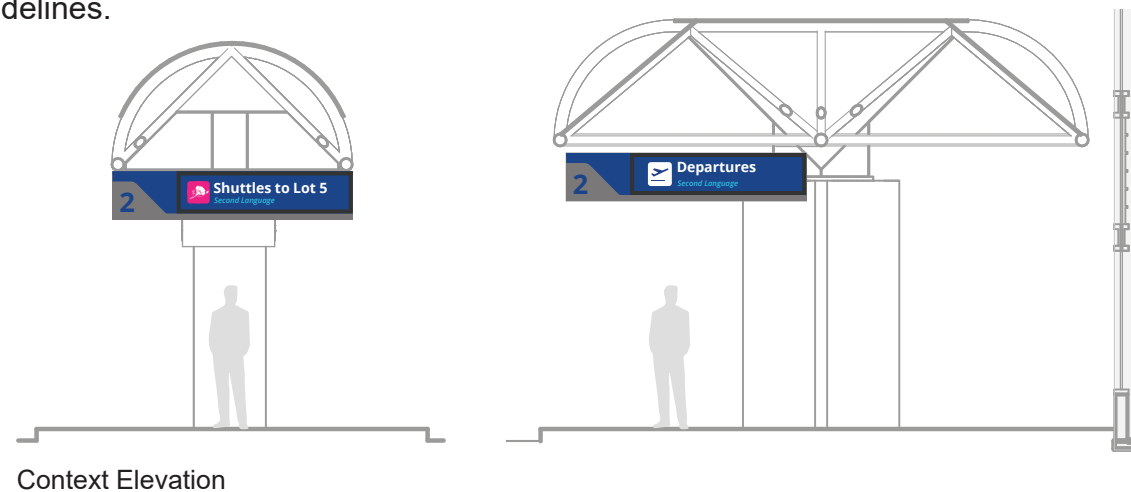
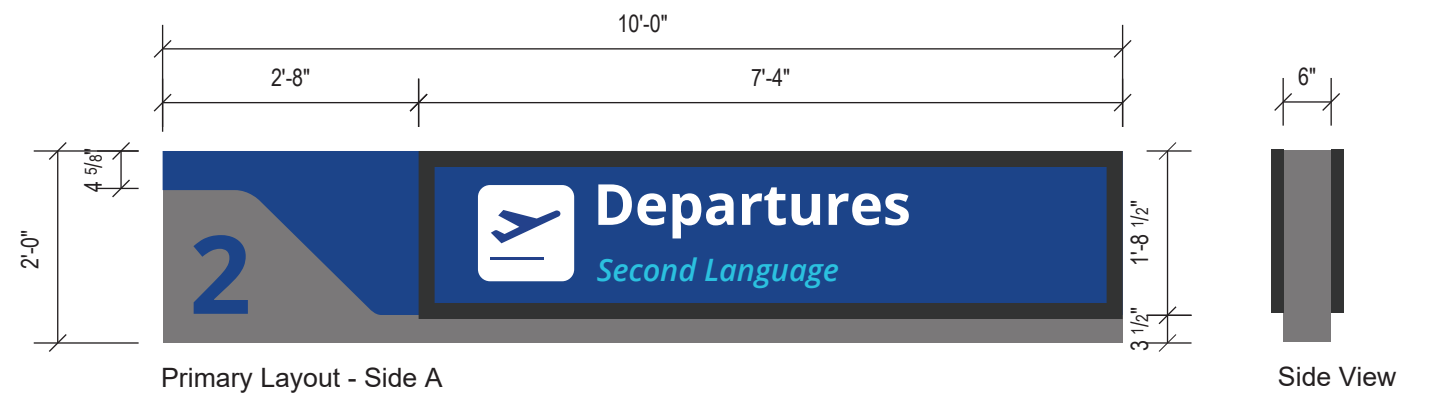
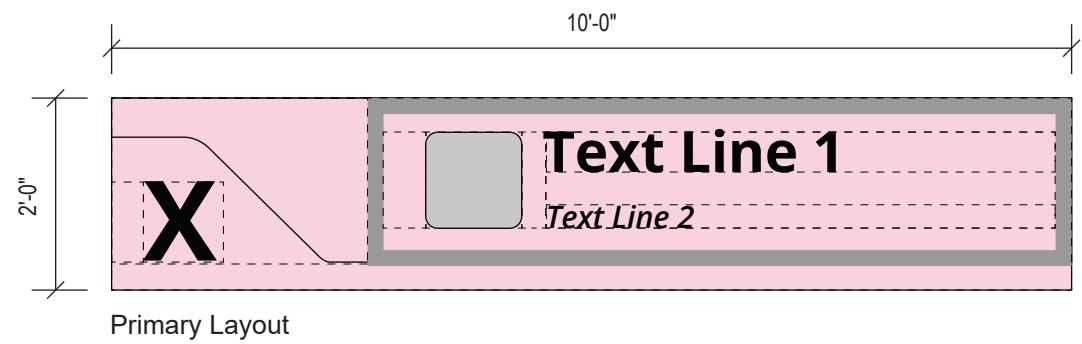
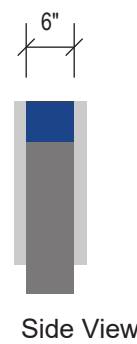

NOTE: Parking Lot icons are placeholders only, ONT to confirm final icons.

L-A1 CURBSIDE OVERHEAD SIGN - ALTERNATE



L-A1-ALTERNATE - Digital Sign
Departures/ Arrivals Curb



L-A1-ALTERNATE - Digital Sign
Shuttles/ Taxi Median

L-B1 OVERHEAD PORTAL SIGN (SINGLE SIDED)

Overhead signs to be placed over terminal entry portals, to direct passengers to drop-off and pick-up for departures, arrivals and various ground transportation services.

Construction Notes:

1. Single faced, 4" deep wall mounted fabricated aluminum sign with LED accent light. Fabricated sign cabinet with internal framing as required.
2. Sign panel to be fabricated aluminum with paint as noted.
3. Copy and graphics to be reflective vinyl die cut in colors indicated.
4. Designer to field verify and determine best method of installation with minimal visual impact. Fabricator to provide structural engineering calculations as required and coordinate with general contractor for structural requirements.
5. Field verify existing conditions.

Note: The scale of signage and graphics is subject to change in order to be compliant with ADA guidelines.

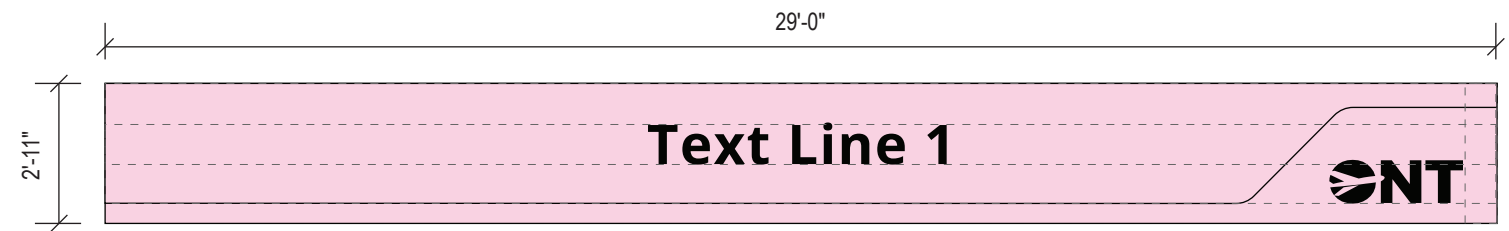

Primary Layout

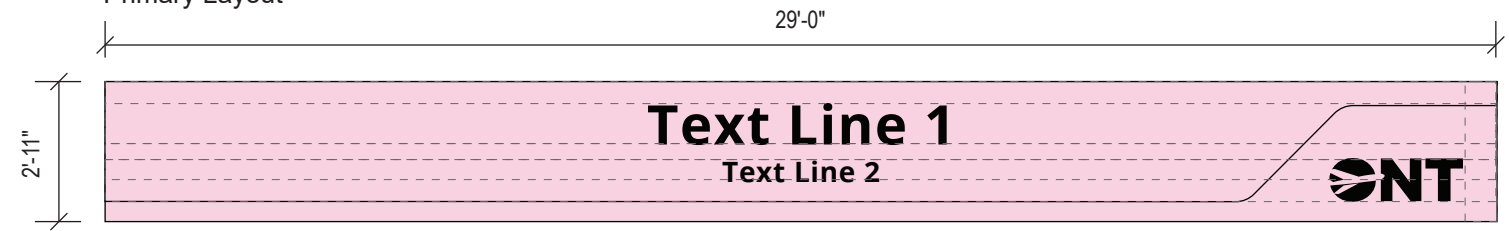

Alternate Layout

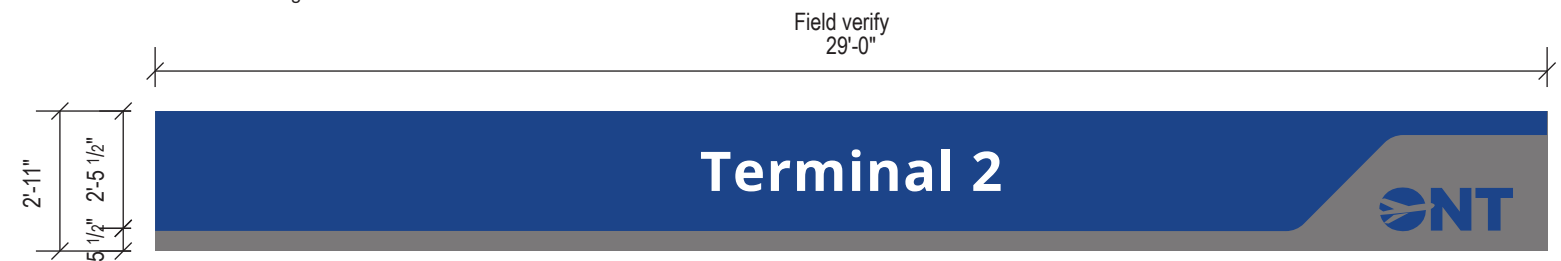
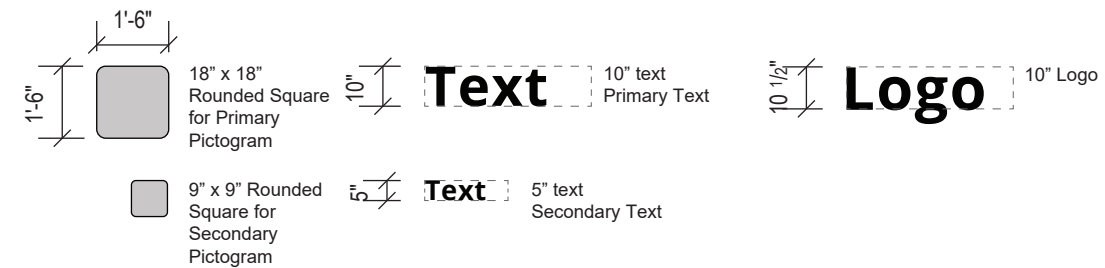

Primary Layout



Alternate Layout

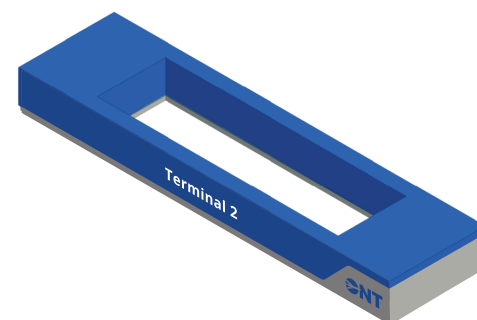

Axonometric

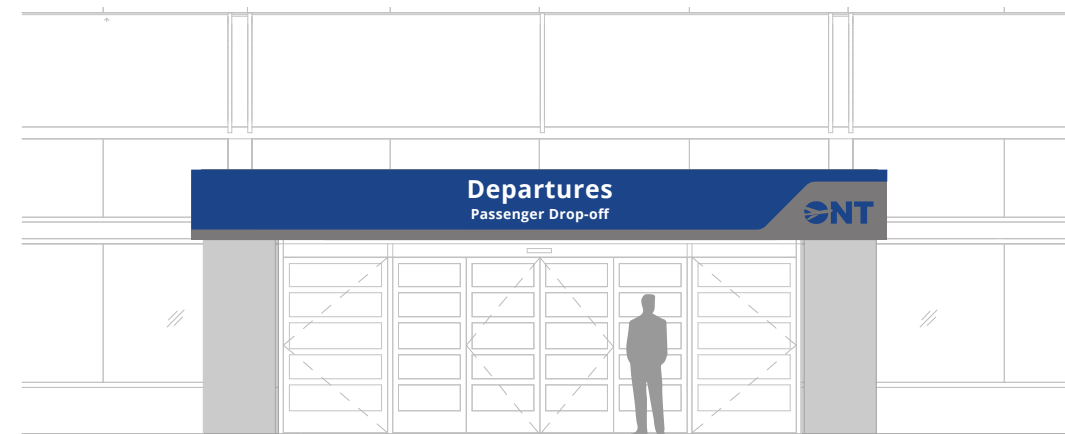

Context Elevation

L-B1 OVERHEAD PORTAL SIGN (SINGLE SIDED)



L-B1 - Static Sign
Departures/ Arrivals Curb

L-B2 OVERHEAD PORTAL SIGN (DOUBLE SIDED)

Overhead signs to be placed over shuttle/ taxi median, to direct passengers to drop-off and pick-up for various ground transportation services.

Construction Notes:

1. Single faced, wall mounted fabricated aluminum sign with LED accent light. Fabricated sign cabinet with internal framing as required. Sign is wrapped around existing canopy and portals, all dimensions to be field verified to match existing architectural conditions at entry portals and canopy.
2. Sign panel to be fabricated aluminum with paint as noted
3. Copy and graphics to be reflective vinyl die cut in colors indicated.
4. Designer to field verify and determine best method of installation with minimal visual impact. Fabricator to provide structural engineering calculations as required and coordinate with general contractor for structural requirements.
5. Field verify existing conditions.

Note: The scale of signage and graphics is subject to change in order to be compliant with ADA guidelines.

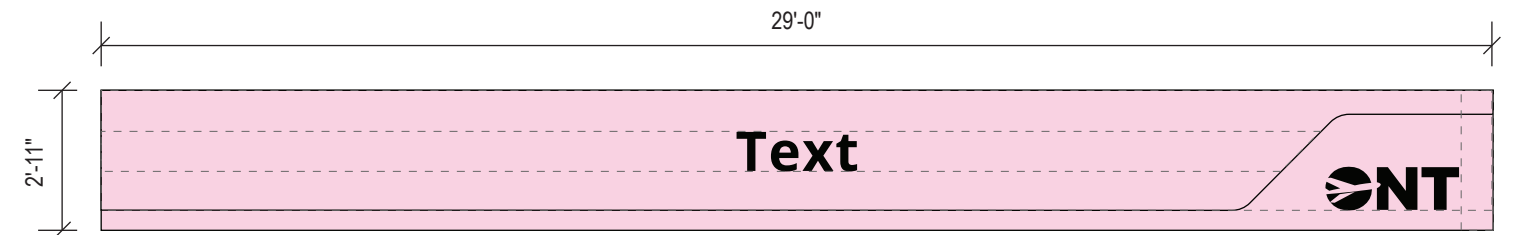

Primary Layout

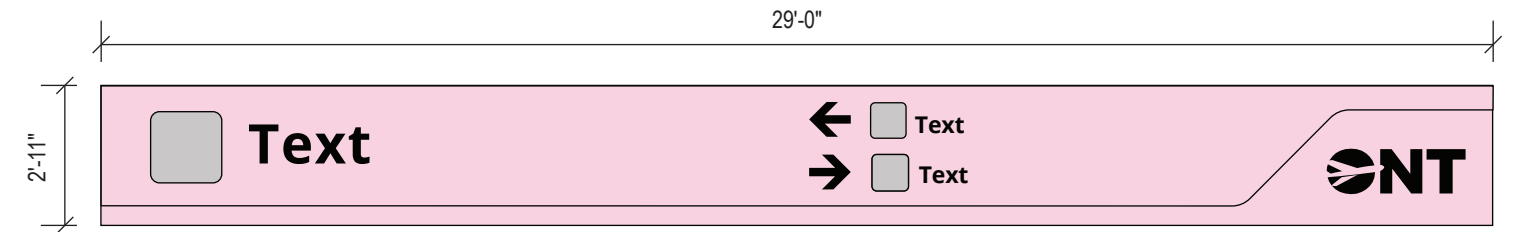

Alternate Layout

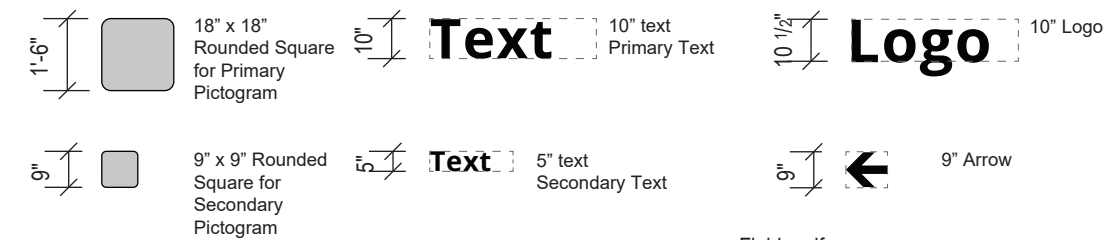

Field verify
29'-0"



Layout - Side A

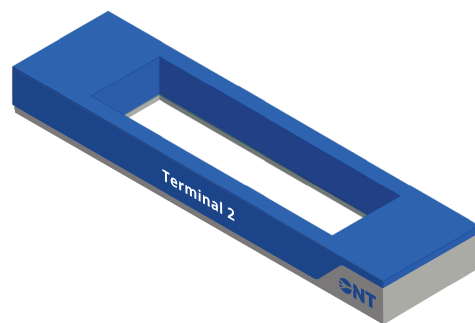

Axonometric

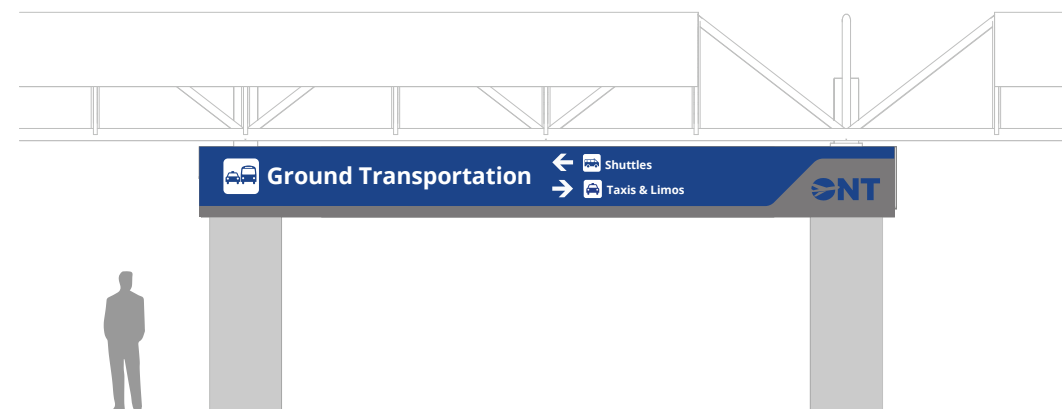

Context Elevation



Layout - Side B

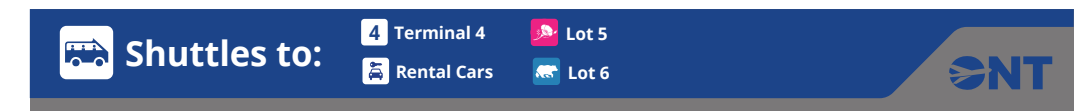

Alternate Layouts

NOTE:
Parking Lot icons are placeholders only, ONT to confirm final icons.

L-B2 OVERHEAD PORTAL SIGN (DOUBLE SIDED)



L-B2 - Side A
Shuttle/ Taxi Median



L-B2 - Side B
Shuttle/ Taxi Median

L-C1 DOOR IDENTIFICATION

Vinyl signs on terminal entry doors, to help identify door numbers.

Construction Notes:

1. Single faced, vinyl sign applied first surface at entry doors. All dimensions to be field verified to match existing door conditions.
2. Copy and graphics to be vinyl die cut in colors indicated.
3. Designer to field verify and determine best method of installation with minimal visual impact. Fabricator to coordinate with general contractor for installation requirements.
4. Field verify existing conditions.

Note: The scale of signage and graphics is subject to change in order to be compliant with ADA guidelines.

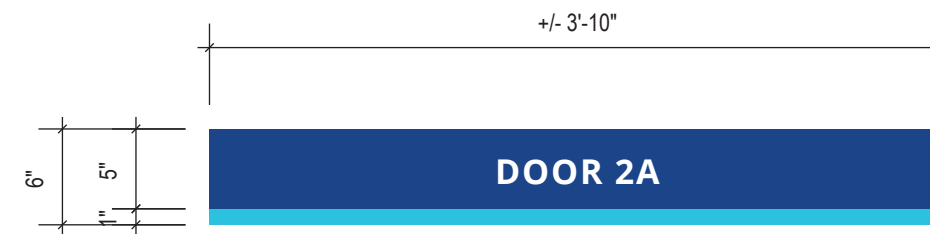

Sign Layout

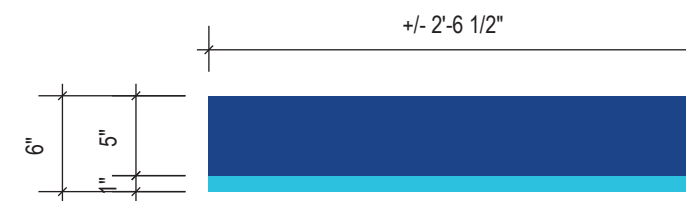

Alternate Vinyl Layout

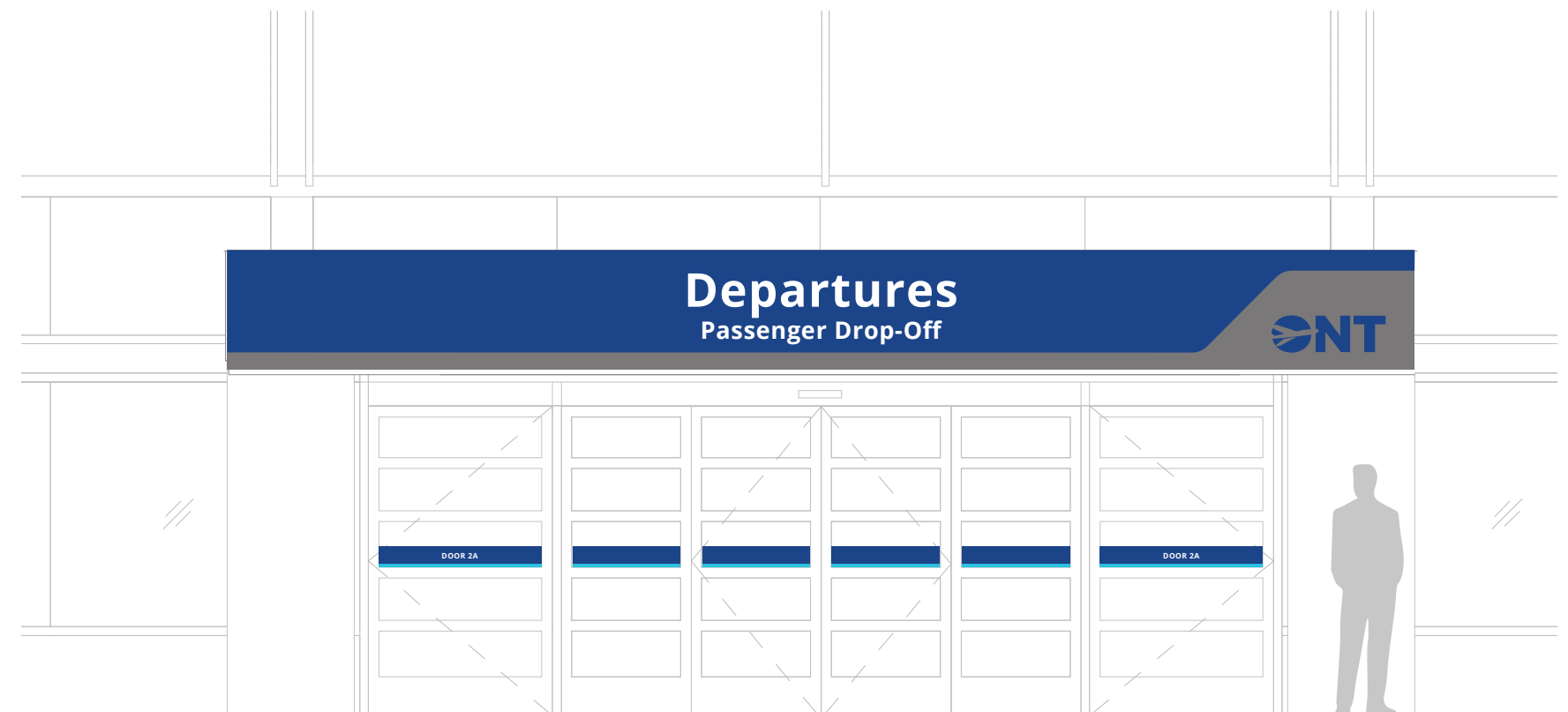

Context Elevation

L-D1 FREESTANDING PYLON (ONE SIDED)

Static freestanding pylon signs at curbside, to help direct arriving passengers to various ground transportation services.

Construction Notes:

1. Single-faced, 8" deep exterior freestanding directional pylon sign with LED accent light.
2. Fabricated aluminum cabinet with internal structure as required.
3. Sign panel to be fabricated aluminum with paint as noted.
4. Copy and graphics to be reflective vinyl die cut in colors indicated.
5. Designer to field verify and determine best method of installation with minimal visual impact, sign to be anchored to concrete. Designer to provide structural engineering calculations as required and coordinate with general contractor for structural requirements.
6. Field verify existing conditions.

Note: The scale of signage and graphics is subject to change in order to be compliant with ADA guidelines.

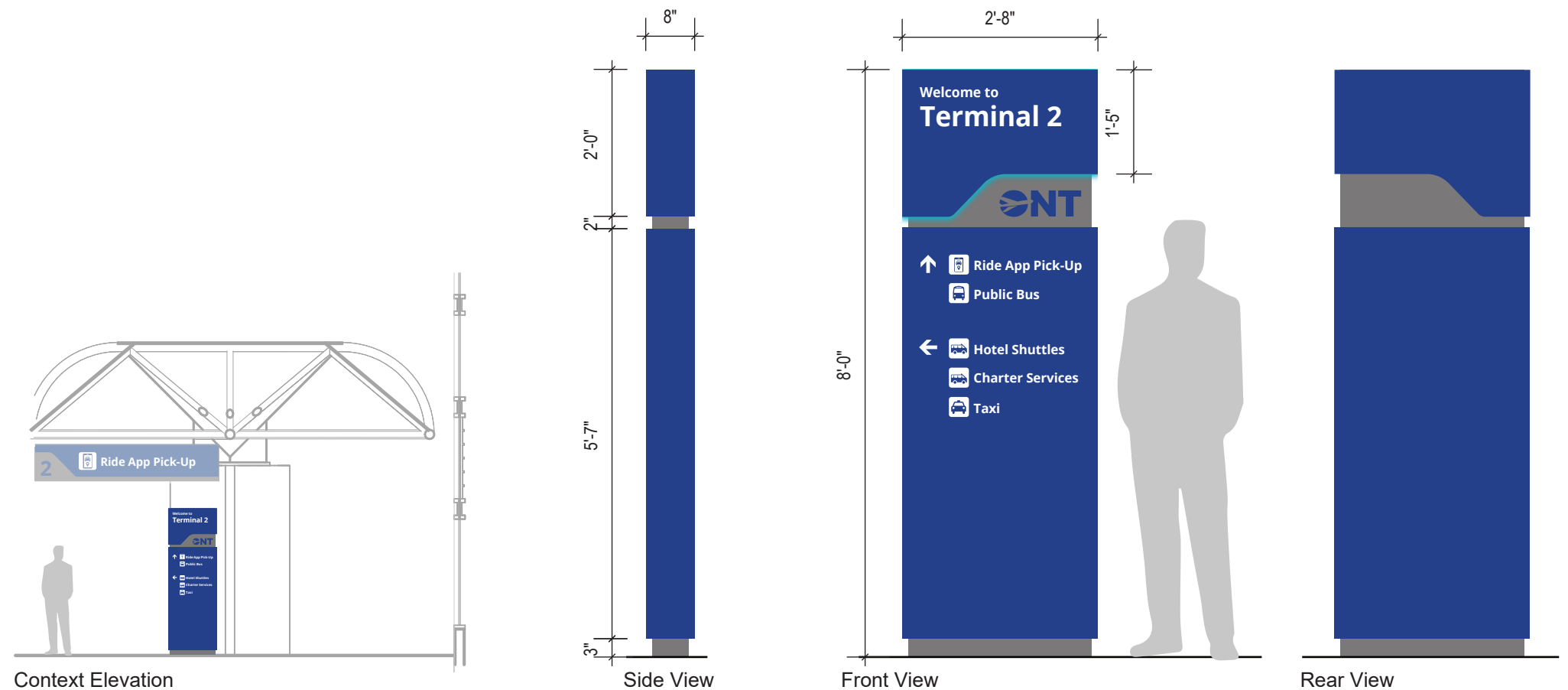

L-D1 FREESTANDING PYLON (ONE SIDED)



L-D1 - Static Freestanding Pylon (Single sided)
Departures/ Arrivals Curb

L-D1 FREESTANDING PYLON (ONE SIDED) ALTERNATE

Digital freestanding pylon signs at curbside, to help direct arriving passengers to various ground transportation services.

Construction Notes:

1. Single-faced, 8" deep exterior freestanding directional pylon sign with LED accent light.
2. Fabricated aluminum cabinet with internal structure as required.
3. Sign panel to be fabricated aluminum with paint as noted.
4. Copy and graphics to be reflective vinyl die cut in colors indicated.
5. When required, LED Display specifications to be approved by ONT. Provide manufacturer's requirements for ventilation in sign cabinet. Allow for ease of maintenance with inconspicuous access panels. Depth of sign may vary according to display specifications.
6. Designer to field verify and determine best method of installation with minimal visual impact, sign to be anchored to concrete. Designer to provide structural engineering calculations as required and coordinate with general contractor for structural requirements.
7. Field verify existing conditions.

Note: The scale of signage and graphics is subject to change in order to be compliant with ADA guidelines.



Context Elevation

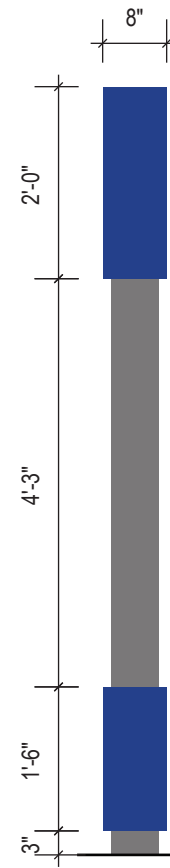

Side View

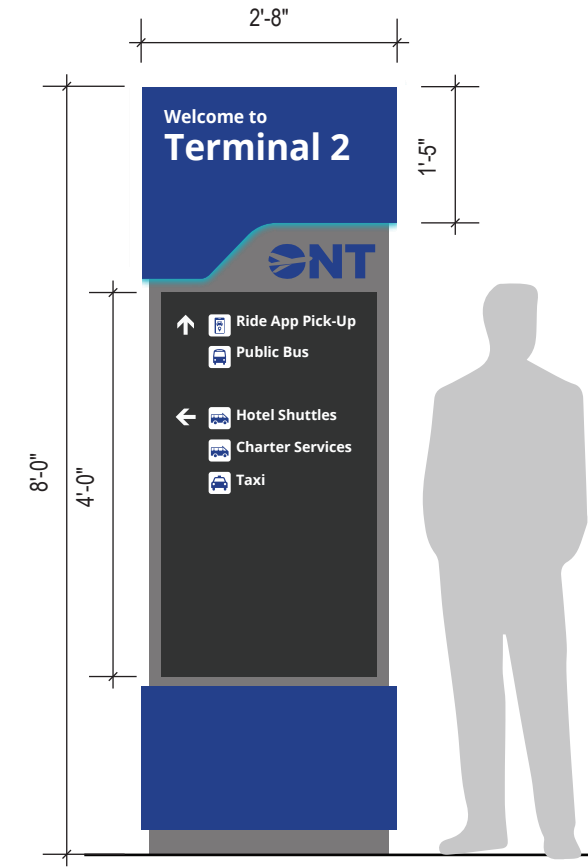

Front View

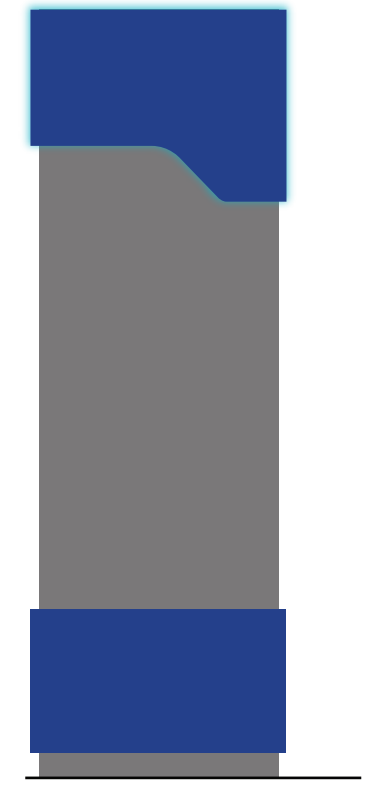

Rear View

L-D1 FREESTANDING PYLON (ONE SIDED) ALTERNATE



L-D1-ALTERNATE - Digital Freestanding Pylon (Single sided)
Departures/ Arrivals Curb

L-D2 FREESTANDING PYLON (DOUBLE SIDED)

Static freestanding pylon signs at median, to help direct arriving passengers to various ground transportation services.

Construction Notes:

1. Double-sided, 8" deep exterior freestanding directional pylon sign with LED accent light.
2. Fabricated aluminum cabinet with internal structure as required.
3. Sign panel to be fabricated aluminum with paint as noted..
4. Copy and graphics to be reflective vinyl die cut in colors indicated.
5. Designer to field verify and determine best method of installation with minimal visual impact, sign to be anchored to concrete. Designer to provide structural engineering calculations as required and coordinate with general contractor for structural requirements.
6. Field verify existing conditions.

Note: The scale of signage and graphics is subject to change in order to be compliant with ADA guidelines.

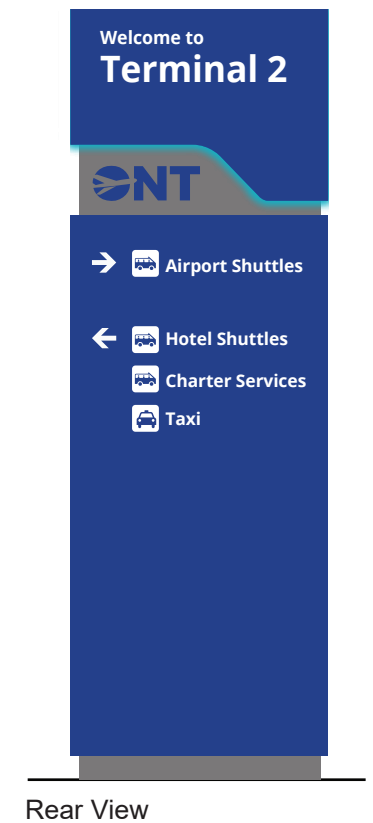
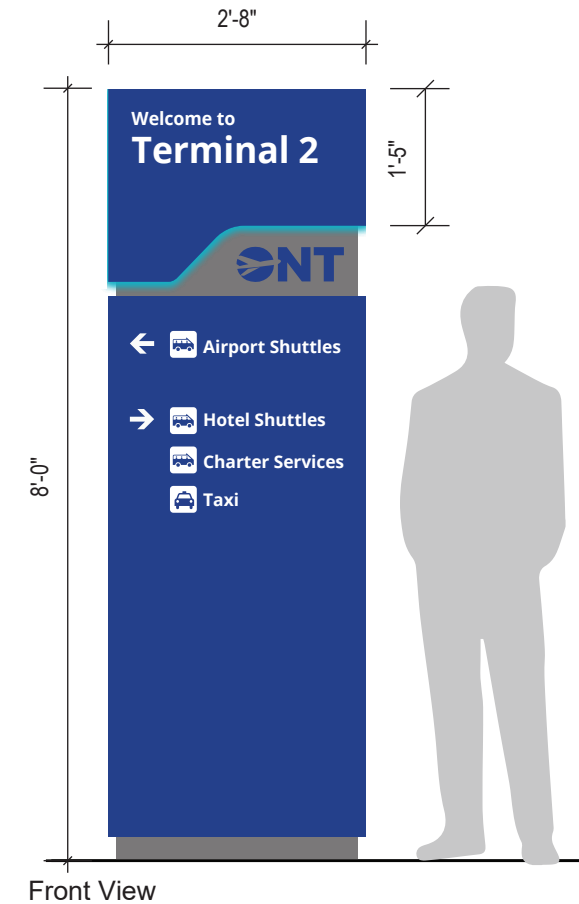
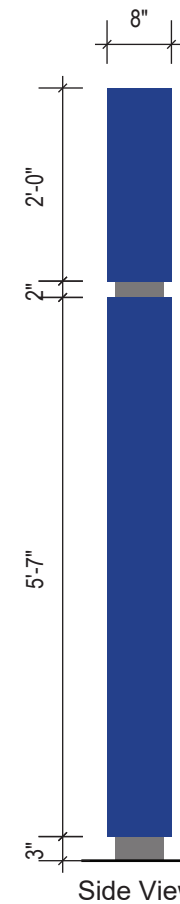
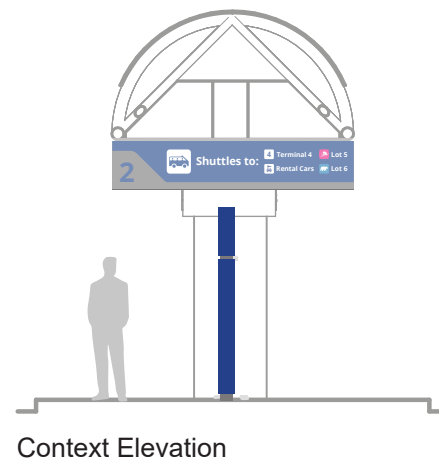

L-D2 FREESTANDING PYLON (DOUBLE SIDED)



L-D2 - Static Freestanding Pylon (Double sided)
Shuttles/ Taxi Median

L-D2 FREESTANDING PYLON (DOUBLE SIDED) ALTERNATE

Digital freestanding pylon signs at median, to help direct arriving passengers to various ground transportation services.

Construction Notes:

1. Double-sided 8" deep exterior freestanding directional pylon sign with LED accent light.
2. Fabricated aluminum cabinet with internal structure as required.
3. Sign panel to be fabricated aluminum with paint as noted.
4. Copy and graphics to be reflective vinyl die cut in colors indicated.
5. When required, LED Display specifications to be approved by ONT. Provide manufacturer's requirements for ventilation in sign cabinet. Allow for ease of maintenance with inconspicuous access panels. Depth of sign may vary according to display specifications.
6. Designer to field verify and determine best method of installation with minimal visual impact, sign to be anchored to concrete. Designer to provide structural engineering calculations as required and coordinate with general contractor for structural requirements.
7. Field verify existing conditions.

Note: The scale of signage and graphics is subject to change in order to be compliant with ADA guidelines.

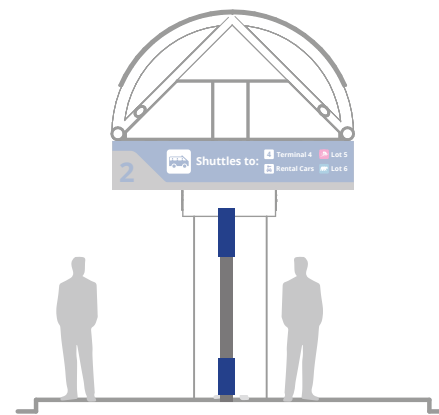

Context Elevation

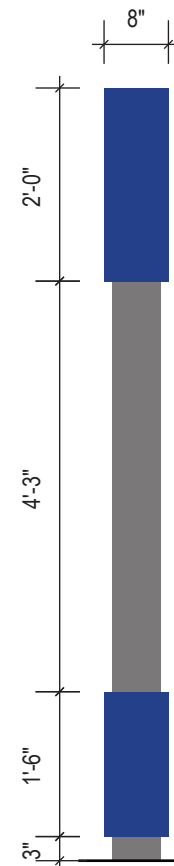

Side View

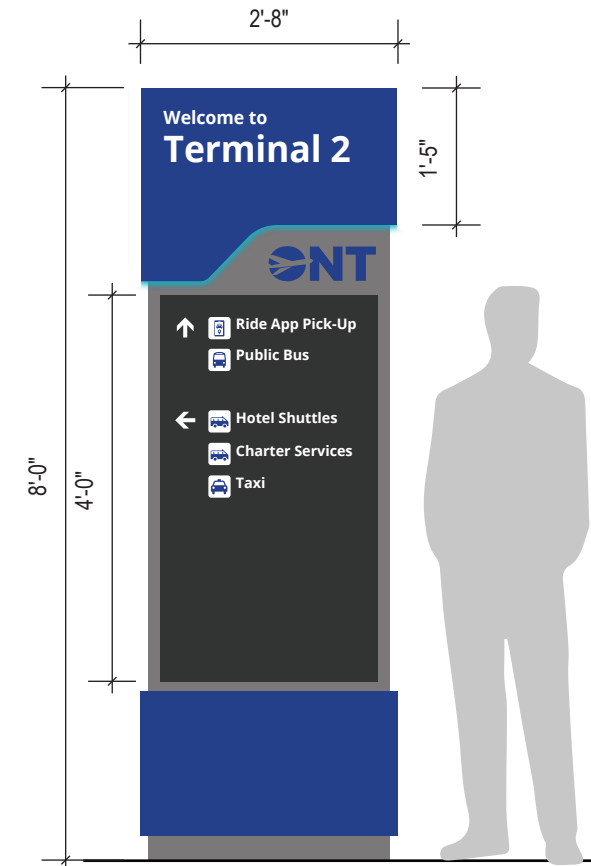

Front View

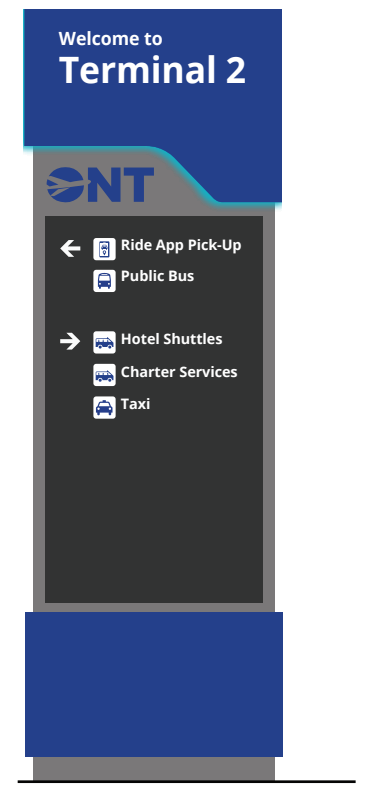

Rear View

L-D2 FREESTANDING PYLON (DOUBLE SIDED) ALTERNATE



L-D2-ALTERNATE - Digital Freestanding Pylon (Double sided)
Shuttles/ Taxi Median

L-E1 FREESTANDING PYLON SIGN (VERTICAL)

Static freestanding pylon signs on sidewalks near parking lots, to help direct passengers to the terminals and provide airline information.

Construction Notes:

1. Single-faced, 8" deep exterior freestanding directional pylon sign.
2. Fabricated aluminum cabinet with internal structure as required.
3. Sign panel to be fabricated aluminum with paint as noted.
4. Copy and graphics to be reflective vinyl die cut in colors indicated.
5. Designer to field verify and determine best method of installation with minimal visual impact, sign to be anchored to concrete. Designer to provide structural engineering calculations as required and coordinate with general contractor for structural requirements.
6. Field verify existing conditions.

Note: The scale of signage and graphics is subject to change in order to be compliant with ADA guidelines.

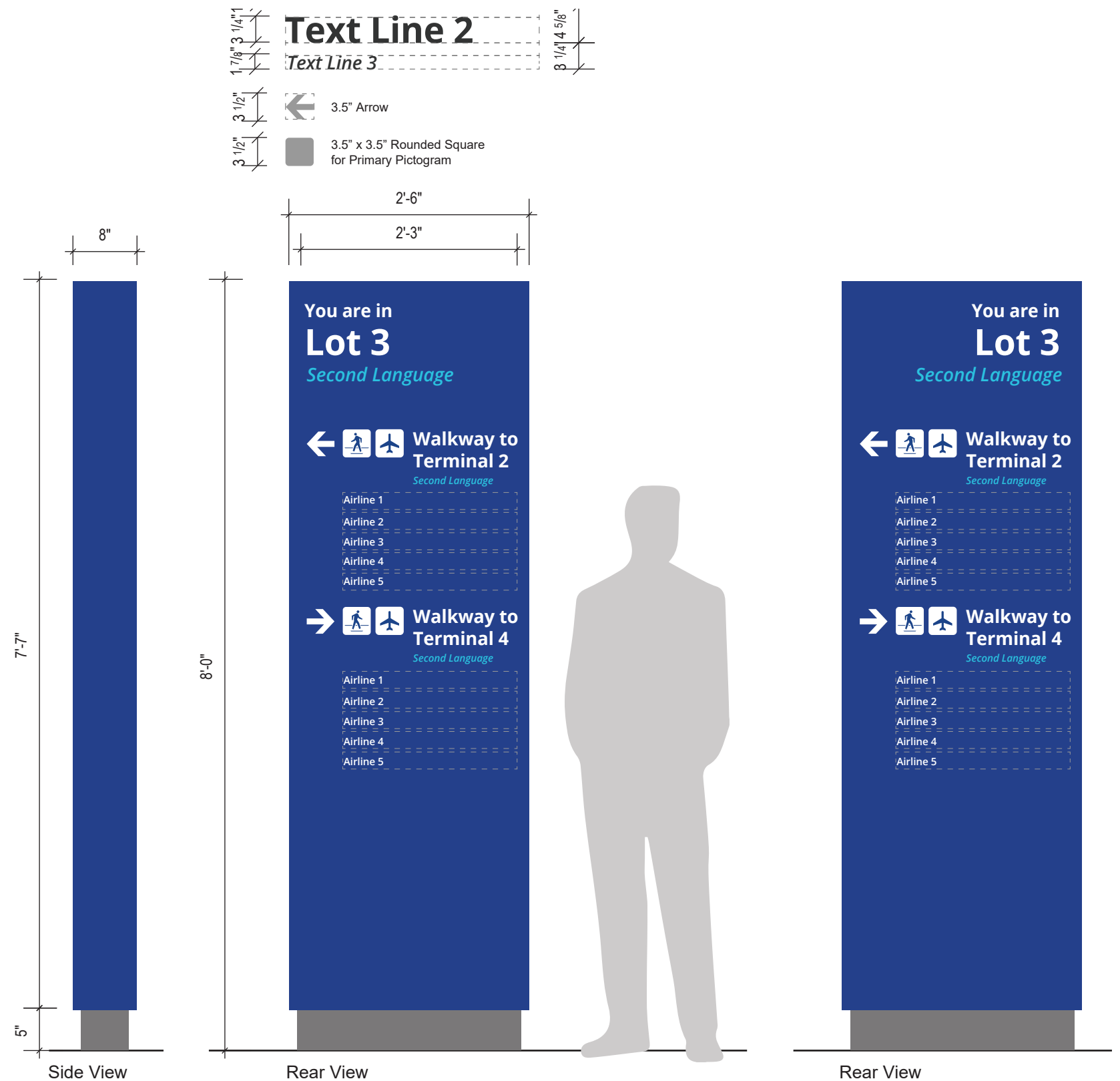

L-E1 FREESTANDING PYLON SIGN (VERTICAL) - ALTERNATE

Digital freestanding pylon signs on sidewalks near parking lots, to help direct passengers to the terminals and provide additional information through digital screens. Content for digital screen can be programmed according to functional needs at specific locations.

Construction Notes:

1. Double faced, 8" deep exterior freestanding directional pylon sign.
2. Fabricated aluminum cabinet with internal structure as required.
3. Sign panel to be fabricated aluminum with paint as noted.
4. Copy and graphics to be reflective vinyl die cut in colors indicated.
5. When required, LED Display specifications to be approved by ONT. Provide manufacturer's requirements for ventilation in sign cabinet. Allow for ease of maintenance with inconspicuous access panels. Depth of sign may vary according to display specifications.
6. Designer to field verify and determine best method of installation with minimal visual impact, sign to be anchored to concrete. Designer to provide structural engineering calculations as required and coordinate with general contractor for structural requirements.
7. Field verify existing conditions.

Note: The scale of signage and graphics is subject to change in order to be compliant with ADA guidelines.

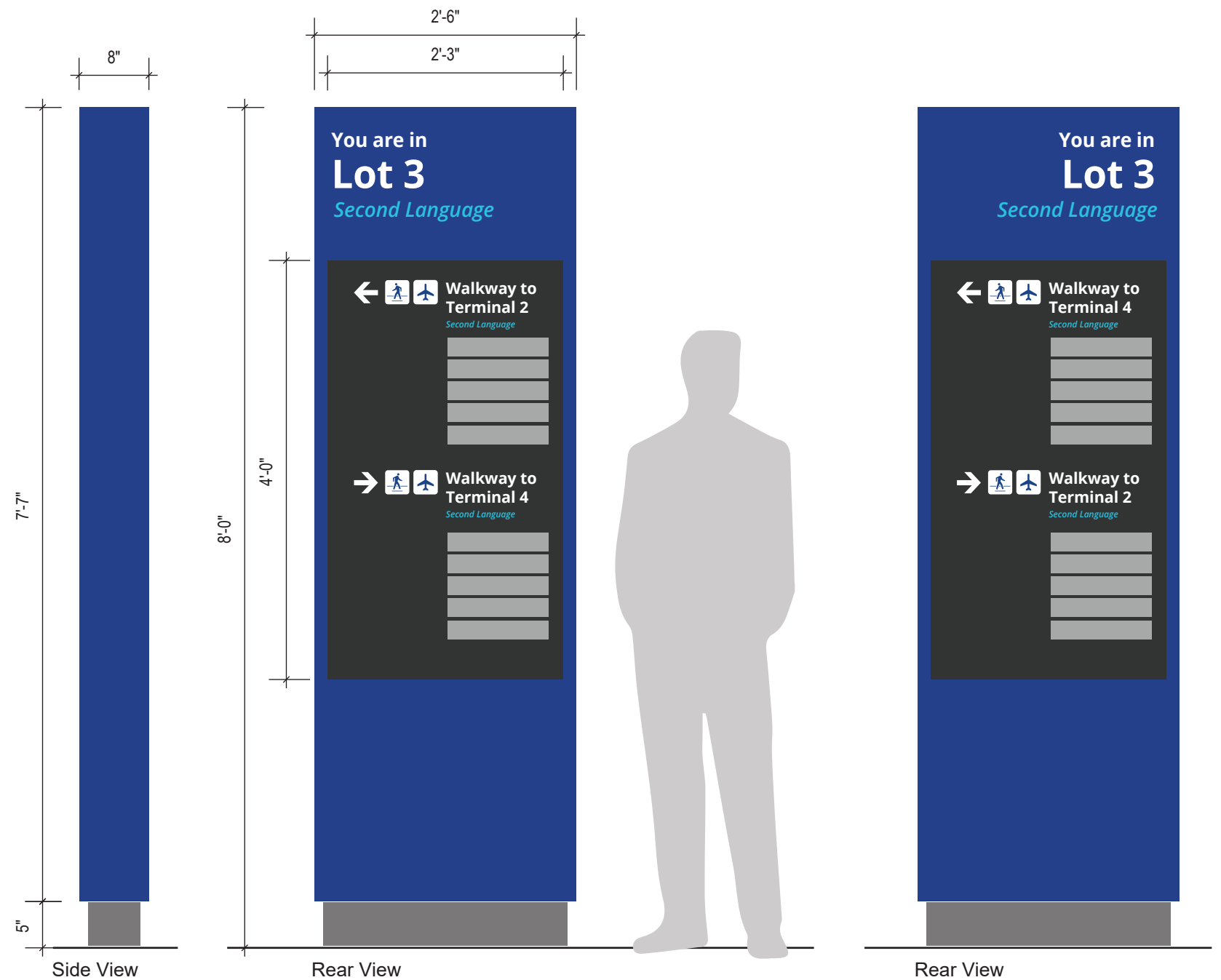

L-E2 LARGE POST & PANEL SIGN

Post and panel signs near parking lot medians, to help direct passengers to the terminals from the parking lot.

Construction Notes:

1. 3" deep double-sided ground mounted post & panel sign.
2. Fabricated painted aluminum sign with applied reflective vinyl graphics in colors as indicated.
3. Painted direct burial aluminum posts, in colors as indicated.
4. Designer to field verify and determine best method of installation with minimal visual impact. Designer to provide structural engineering calculations as required and coordinate with general contractor for structural requirements.
5. Field verify existing conditions.

Note: The scale of signage and graphics is subject to change in order to be compliant with ADA guidelines.

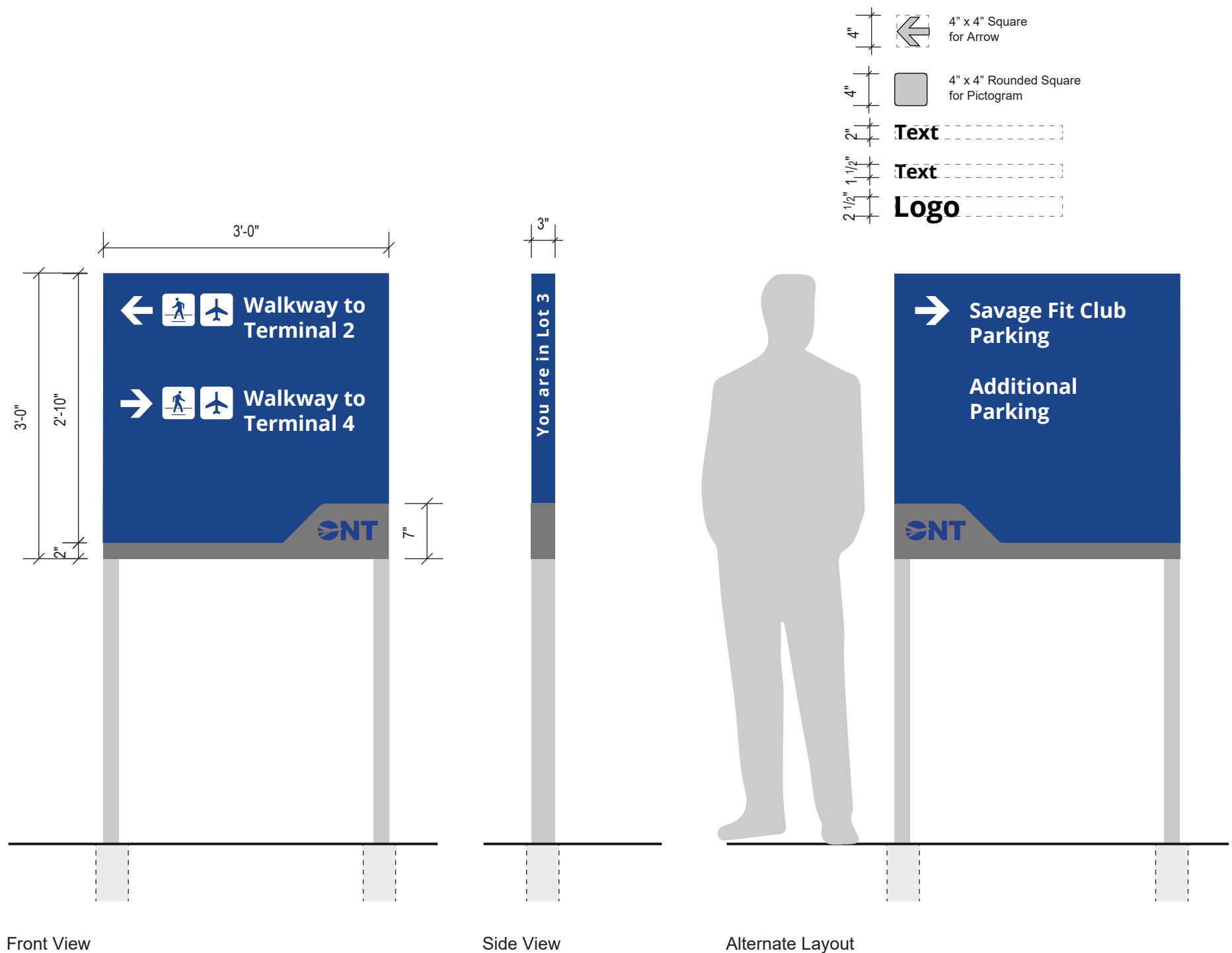

L-E2 LARGE POST & PANEL SIGN



L-E2 - Post and panel sign
Parking Lot Median

L-F1 FREESTANDING PYLON SIGN (HORIZONTAL)

Freestanding pylon signs near building entrances, to help drivers identify the building address and name.

Construction Notes:

1. Double-faced, 10" deep internally illuminated painted aluminum sign with push-thru acrylic letters and concrete base.
2. Copy and graphics to be in colors indicated.
3. Light blue LED accent lighting on the ascent.
4. ONT logo to be lit dark blue at night. Fabricator to coordinate color match and lighting method, approval by ONT is required.
5. Fabricated aluminum cabinet with internal structure as required.
6. Designer to field verify and determine best method of installation with minimal visual impact, sign to be anchored to concrete. Designer to provide structural engineering calculations as required and coordinate with general contractor for structural requirements.
7. Field verify existing conditions.

Alternate: Externally illuminated sign with painted aluminum structure with LED accent light. Copy and graphics to be reflective vinyl in colors as indicated.

Note: The scale of signage and graphics is subject to change in order to be compliant with ADA guidelines.

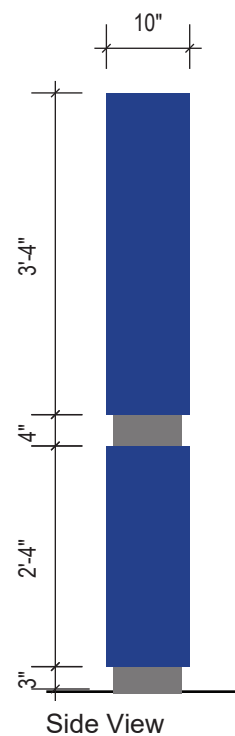
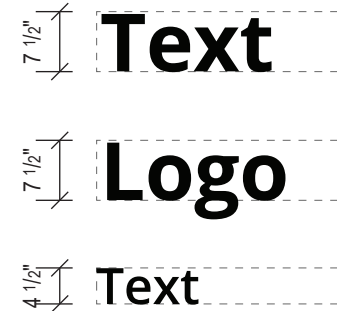

Terminal Signage Standards

General Information

Image & Text Size

Imagery is limited to the corporate branding elements only; no additional copy, slogans or information.

Colors & Fonts

Colors and fonts are limited to the ONT branding only.

Material

Typical sign construction must be painted aluminum or acrylic with applied vinyl, exceptions noted on each sign.

Illumination (internal or external) to be coordinated and field verified according to location.

Code Requirement

All signage to conform to the current sign codes.

Terminal Signs

Exterior

Building Identification Signs

Interior

Directional Signs

Identification Signs

Freestanding Pylon

Room Identification Signs

Door Identification Signs

Restroom Identification Signs

Authorized Personnel Only Signs

Check In Backwall

Check In Desk

Queue

Pylons

Gate Counter Backwall

Gate Counter

Baggage Claim

Baggage Service Office

Terminal Signage Standards

General Information

People looking for destinations and information require signs—both text and graphic elements to guide them. In a civic environment such as ONT, signs identify traffic routes, buildings, facilities, and activities.

Graphic elements are an integral part of the visual landscape at ONT—the image overlap of two and three dimensional forms together make up our civic architecture. It is important that these elements, which identify and inform, be visually integrated to their site and structure.

The ONT Terminal Signage Standards are designed to promote a well-integrated, complete signage program that will help the public use the airport efficiently and with a minimum amount of confusion. These standards cover both exterior as well as interior signage for all of the Terminal property under the jurisdiction of Ontario International Airport Authority (OIAA).

These Standards will function as an efficient reference source, while at the same time promote terminal signage that is attractive and utilizes colors and materials that are compatible with its surroundings.

Please note that these Terminal Signage Standards are not applicable to concession signage or advertising. Inquiries regarding these topics should be directed to OIAA.

INTENT OF TERMINAL SIGNAGE AT ONT

Tenants are encouraged to be expressive and imaginative when designing signs to aid the public in using airport facilities efficiently and with a minimum of confusion. In short, the acceptable criteria for each sign is that it address the immediate needs of airport users.

The intent of signage is to provide adequate direction so that the sign systems will:

1. Provide an effective source of needed information
2. Maintain quality of design that is compatible with the aesthetics of ONT. Great importance is placed on good taste, originality, and fine materials.
3. Be attractive and use colors and materials that are compatible with the design of individual Terminals.

PURPOSE OF THE TERMINAL SIGNAGE STANDARDS

The Tenant Signage Standards establish conformance criteria for all signage proposed for existing, new and remodeled facilities under OIAA jurisdiction at the airport and its environs. These Standards are meant to provide the maximum limitations for tenant signing of any kind allowed in these areas.

The Standards will be periodically reviewed by OIAA and are subject to revision at its discretion.

SIGN SUBMITTAL & OIAA APPROVAL

All signs must be approved by the OIAA prior to installation. New, changed or renovated signs must conform to these Standards.

If any existing sign exceeds the limitation stated in the Standards, but has been previously approved by OIAA, that sign will be replaced to conform to the current standards in a reasonable amount of time as determined by OIAA.

Temporary signs must be submitted for review and approval prior to installation. Refer to the “Temporary Signage Standards” section for details.

REVIEW & COMPLIANCE

All signs are subject to periodic reviews by OIAA to ensure compliance to these Standards. Signs will be inspected for content compliance and to ensure that the minimum sign fabrication quality is maintained. This will include sign structure, paint or finish, and applied materials, i.e. plastics, vinyl lettering, fasteners, etc. Internally illuminated signs will be checked for proper working order before final acceptance.

In the event that an existing sign is found to be out of compliance with these Standards, OIAA will notify the tenant with a written notice. The tenant is required to remove and refurbish the sign up to or exceeding the quality of the original permitted condition according to the guidelines described in the Regulation Enforcement section of these Standards. If the tenant’s sign does not satisfy permitted condition standards at the end of the prescribed adjustment period, OIAA reserves the right to directly resolve the matter by removing it and billing all costs to the tenant.

REGULATION ENFORCEMENT

All tenants must obtain the written approval of OIAA for each sign. Any sign installed without the written approval of OIAA must be removed within 48 hours.

If the tenant does not remove the sign in the allotted time, OIAA reserves the right to directly resolve the matter by removing it and billing all costs to the tenant.

Previously approved existing signs that do not conform to these Standards will be replaced to conform to the current Standards in a reasonable amount of time as determined by OIAA.

Tenants may change or alter an existing permanent sign only with the written approval of OIAA. If leaseholds are modified or improved, any existing signage within the improvement area must conform to these Standards. Such existing signage may require a full replacement.

OIAA WAYFINDING SIGNS

Airport wayfinding signs are under the sole jurisdiction of OIAA. Included in this sign category are roadway signs, parking structure signs, terminal under-canopy signs located along the curbside, the interior terminal wayfinding signs and directional signs in public buildings controlled by the airport authority.

All designations are at the sole discretion of OIAA.

U.S. CUSTOMS SIGNAGE GUIDELINES

Signage in the Federal Inspection Service Area (FIS) is the responsibility of OIAA.

All signage in the Federal Inspection Service Areas are mandated to strictly adhere to U.S. Customs and Border Protection signage guidelines for verbiage, colors and sign specifications.

Standards & Regulations

RESPONSIBILITY & INTENT

1. Signage in public areas is the responsibility of OIAA. Signage within leased areas is the responsibility of the tenant.
2. All signs will be of an informative nature designed to meet the immediate needs of the public. Signs of an advertising or promotional nature are not permitted unless an executed Advertising Agreement is in place with OIAA.
3. Signs not covered in these standards are to be approved by OIAA.

APPLICABLE CODE REQUIREMENTS

The tenant will have sole responsibility for compliance with all applicable federal, state, and local building codes, ordinances and other jurisdictional regulations including ADA.

SIGN PLACEMENT

1. No signs will be permitted on doors or windows except those required to meet safety or regulatory standards. Some exceptions are noted in these Standards.
2. No signs will be permitted on the roof of any building. This regulation also applies to any structure atop a building.
3. All signs are to be surfaced-mounted within the architectural elevation of the demised premises unless otherwise approved by OIAA.

ILLUMINATION

1. Only individually mounted, internally illuminated letters, pin mounted and back washed letters are acceptable.
2. No exposed neon, animated, or flashing signs are permitted. Internally illuminated signs will be kept to a minimum using translucent acrylic diffusion to control the brightness. Illuminated signs will be allowed only in specific circumstances mentioned in the text of these standards. All illuminated signs will meet all code requirements and bear the label of the Underwriters Laboratories, Inc.

ACCEPTABLE MATERIALS

1. Porcelain enamel on aluminum or aluminized sheet steel
2. Anodized aluminum
3. Paint on aluminum—paint must be linear polyurethane for all under coats and top coats
4. Acrylic and fiberglass with satin finish only
5. Copy application must be achieved by screen process or cut-out lettering applique only.
6. Other materials may be reviewed and considered by OIAA.

The materials listed above are not acceptable for illuminated signs.

FABRICATION & INSTALLATION

The fabrication and installation of all signs will be of a permanent nature using established methods and quality materials and hardware. Only high-quality workmanship performed by qualified tradespeople will be permitted.

Attachment hardware and connections of all signs must be non-corrosive and engineered to ensure public safety. No exposed can, raceways, or crossovers will be permitted. Fabrication and installation must comply with all applicable City of Ontario Building and Sign Codes.

MAINTENANCE

Tenants must maintain each approved sign in a neat, clean, orderly and safe manner. Failure to maintain an approved sign will result in revocation of approval and subsequent removal.

OIAA STANDARD FONTS

Open Sans is the font standard for exterior and interior wayfinding signs for Ontario International Airport. The approved font should be used as the default typefaces respectively for all directional and secondary text on signage where the tenant's corporate font is not used. The Ontario International Airport Brand Guide shall be used to determine the fonts and colors where appropriate.

OIAA STANDARD FONTS AND PRIMARY BRANDING COLORS

Open Sans

ABCDEFGHIJKLMNOPQRSTUVWXYZ
abcdefghijklmnopqrstuvwxyz
1234567890

Open Sans Bold

ABCDEFGHIJKLMNOPQRSTUVWXYZ
abcdefghijklmnopqrstuvwxyz
1234567890



PANTONE: 7687 C
CMYK: 76, 53, 0, 45
RGB: 33, 65, 139
HEX: 21418B



PANTONE: 311 C
CMYK: 83,13, 0, 13
RGB: 37, 193, 222
HEX: 25C1DE



PANTONE: Cool Gray 9C
CMYK: 55 M.47 Y.44 K.11
RGB: 119 G.118 B.121
HEX: 767679

Outline of Sign Types

Terminal Wayfinding Signage



T-A1 OVERHEAD DIRECTIONAL LARGE - CEILING MOUNTED

T-A2 OVERHEAD DIRECTIONAL LARGE - WALL MOUNTED



T-B1 GATE ID - CEILING MOUNTED



T-C1 SYMBOL ID - FLAG MOUNTED

T-C2 SYMBOL ID - WALL MOUNTED



T-E1 ELEVATOR ID - WALL MOUNTED



T-F1 OVERHEAD DIRECTIONAL SMALL - CEILING MOUNTED



T-D1 FREESTANDING PYLON

Outline of Sign Types

Terminal Wayfinding Signage

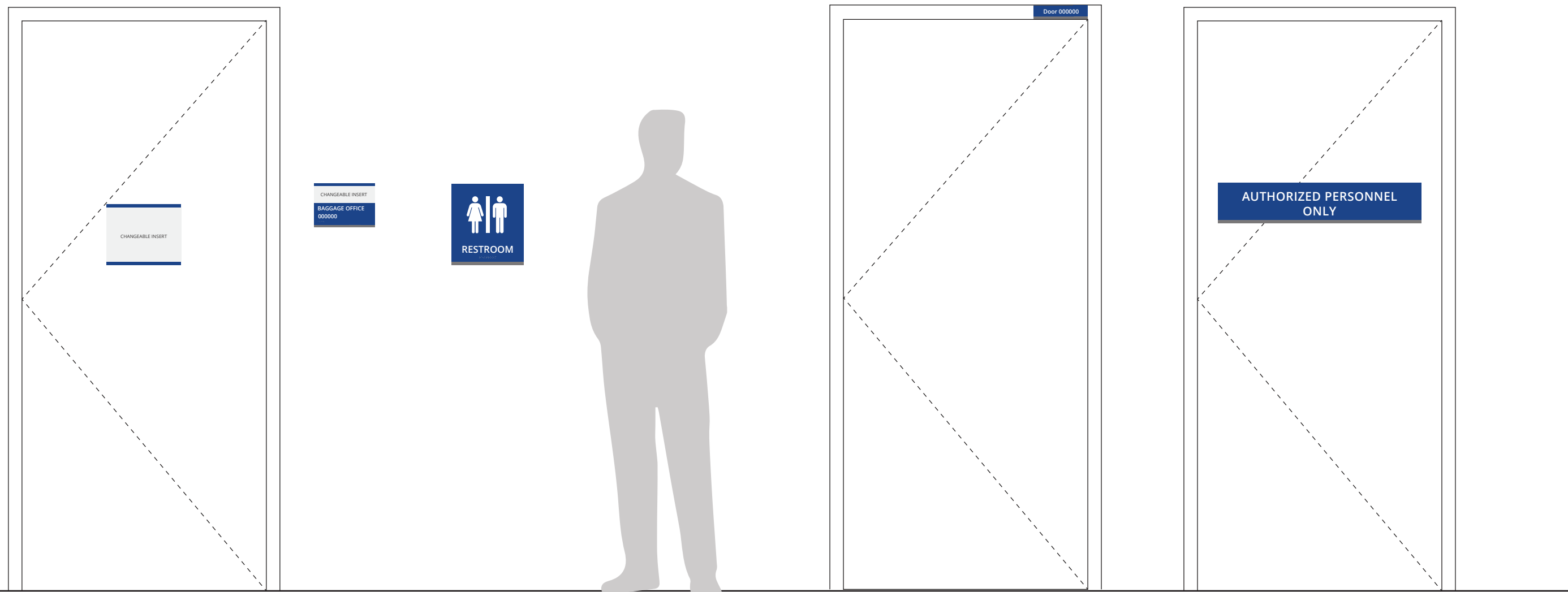

T-G1 ROOM IDENTIFICATION SIGN

T-G2 RESTROOM IDENTIFICATION SIGN

T-G3 DOOR IDENTIFICATION SIGN

T-G4 AUTHORIZED PERSONNEL ONLY SIGN

Outline of Sign Types

Terminal Wayfinding Signage

Terminal

T-H1 BUILDING IDENTIFICATION CHANNEL LETTERS

2222 International Way

T-H2 BUILDING ADDRESS DIMENSIONAL LETTERS

Dianne Feinstein
International
Terminal



T-J1 BUILDING IDENTIFICATION SIGN

T-A1 OVERHEAD DIRECTIONAL LARGE - CEILING MOUNTED

Ceiling mounted directional signs to be placed in the terminal, to guide passengers to their destinations.

Construction Notes:

1. Double faced, ceiling mounted fabricated aluminum sign with LED accent light.
2. Fabricated sign cabinet with internal framing as required.
3. Sign panel to be fabricated aluminum with paint as noted.
4. Copy and graphics to be vinyl die cut in colors indicated.
5. Designer to field verify and determine best method of installation with minimal visual impact. Designer to provide structural engineering calculations as required and coordinate with general contractor for structural requirements.
6. Field verify existing conditions.
7. Vertical supports and bracket with decorative cladding as required. Provide smallest diameter as allowed by structural engineering calculations.

Note: The scale of signage and graphics is subject to change in order to be compliant with ADA guidelines.

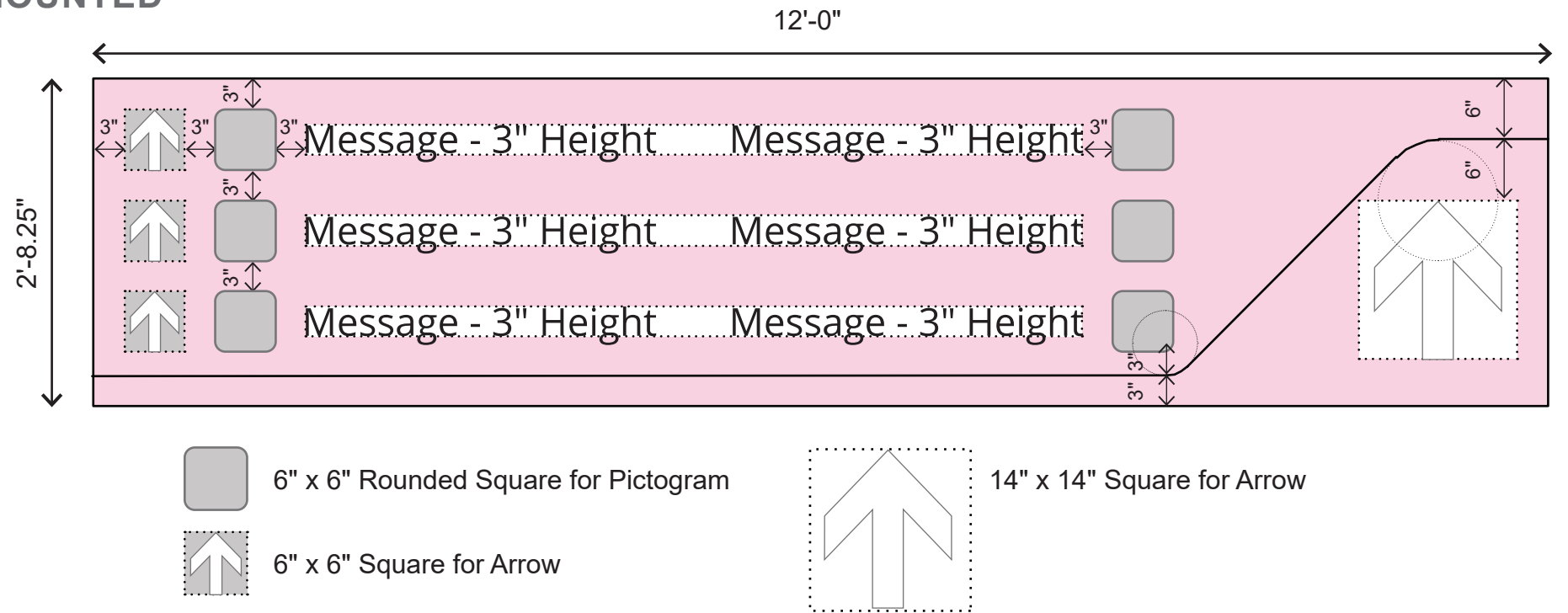

Primary Layout

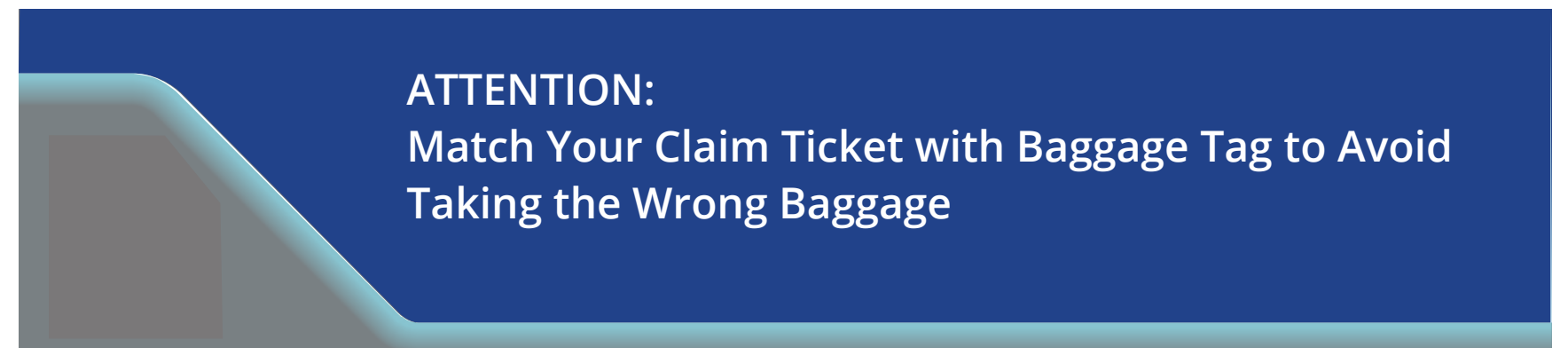

Alternate Layout

T-A2 OVERHEAD DIRECTIONAL LARGE - WALL MOUNTED

Wall mounted directional signs to be placed in the terminal, to guide passengers to their destinations.

Construction Notes:

1. Single faced, wall mounted fabricated aluminum sign with LED accent light.
2. Fabricated sign cabinet with internal framing as required.
3. Sign panel to be fabricated aluminum with paint as noted.
4. Copy and graphics to be vinyl die cut in colors indicated.
5. Designer to field verify and determine best method of installation with minimal visual impact. Designer to provide structural engineering calculations as required and coordinate with general contractor for structural requirements.
6. Field verify existing conditions.
7. Vertical supports and bracket with decorative cladding as required. Provide smallest diameter as allowed by structural engineering calculations.

Note: The scale of signage and graphics is subject to change in order to be compliant with ADA guidelines.

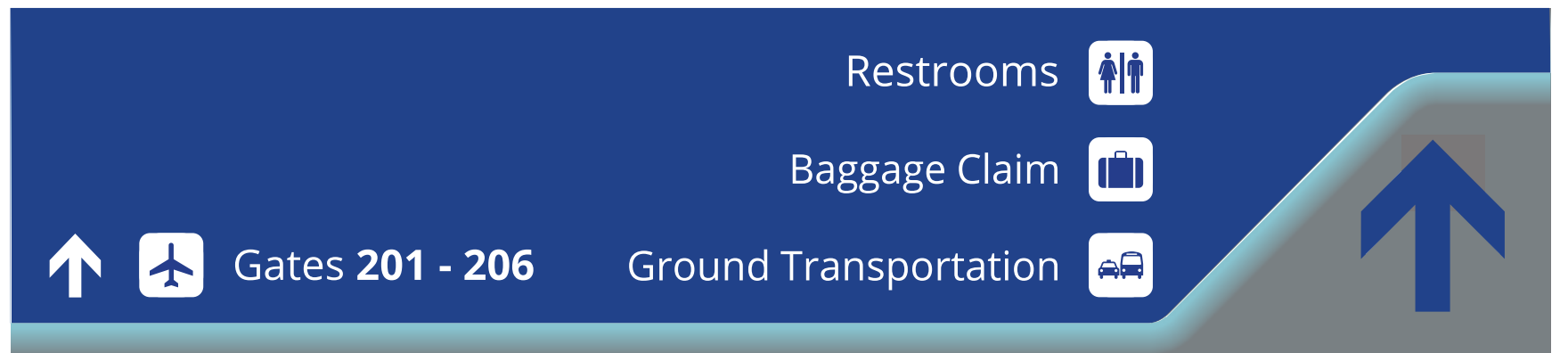
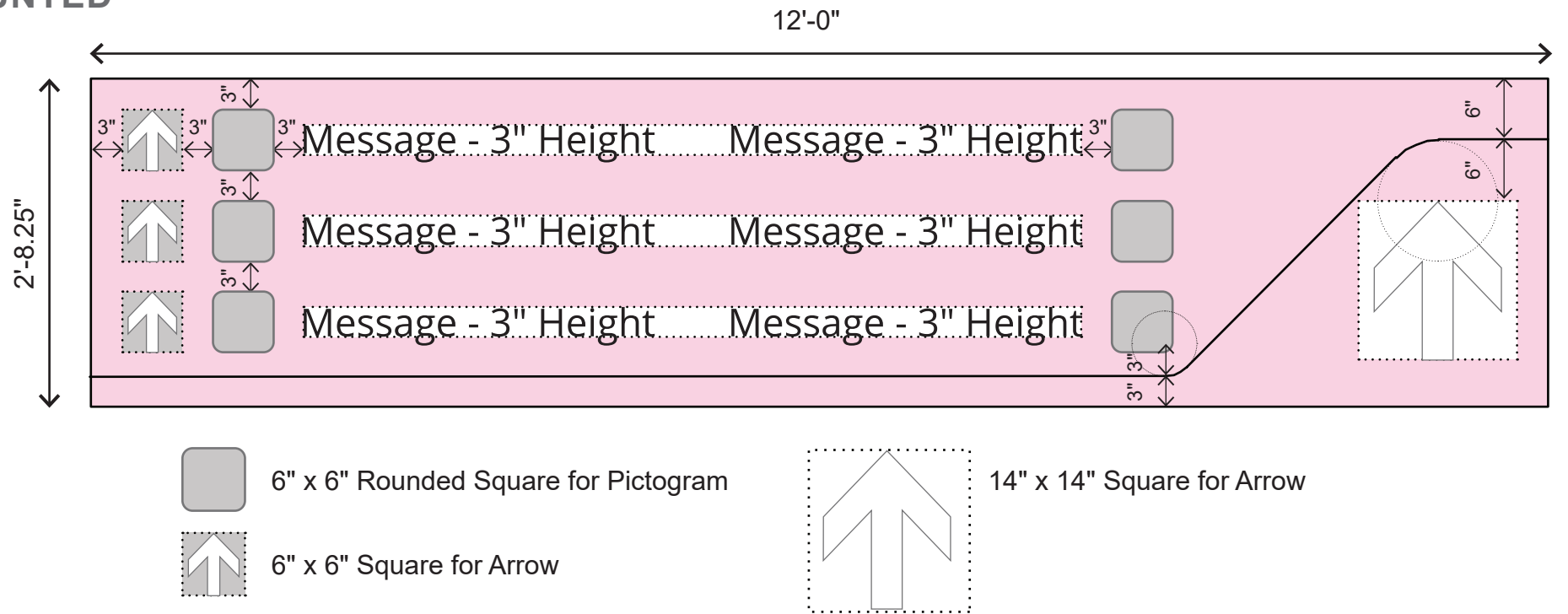

Primary Layout

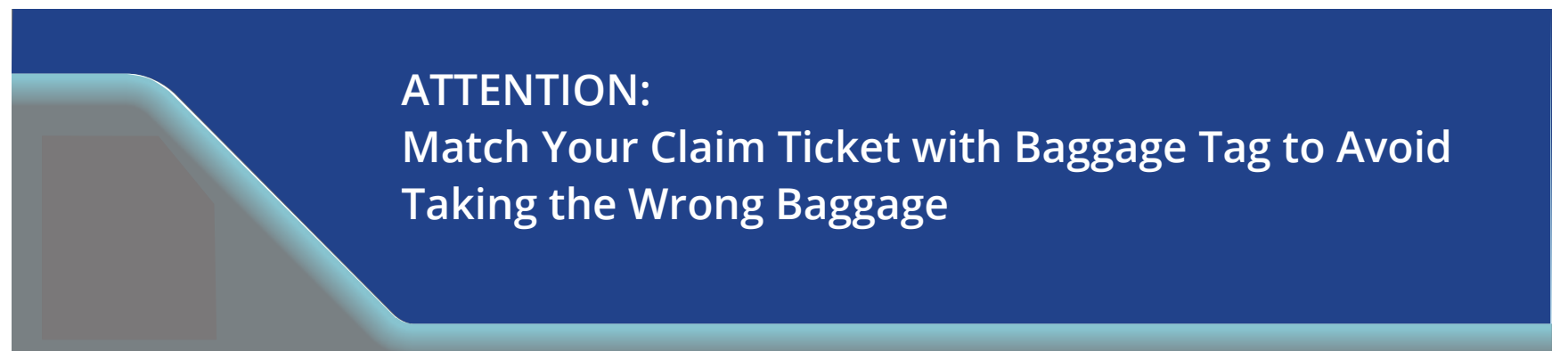

Alternate Layout

T-B1 GATE ID - CEILING MOUNTED

Ceiling mounted signs to help passengers identify their gate numbers in the terminal.

Construction Notes:

1. Double faced, ceiling mounted fabricated aluminum sign with LED accent light.
2. Fabricated sign cabinet with internal framing as required.
3. Sign panel to be fabricated aluminum with paint as noted
4. Pictograms to be flat-cut out 1/4" thick aluminum painted in colors as noted. Pictograms to be mounted to sign panel with hidden mechanical fasteners.
5. Designer to field verify and determine best method of installation with minimal visual impact. Designer to provide structural engineering calculations as required and coordinate with general contractor for structural requirements.
6. Field verify existing conditions.
7. Vertical supports and bracket with decorative cladding as required. Provide smallest diameter as allowed by structural engineering calculations.

Note: The scale of signage and graphics is subject to change in order to be compliant with ADA guidelines.

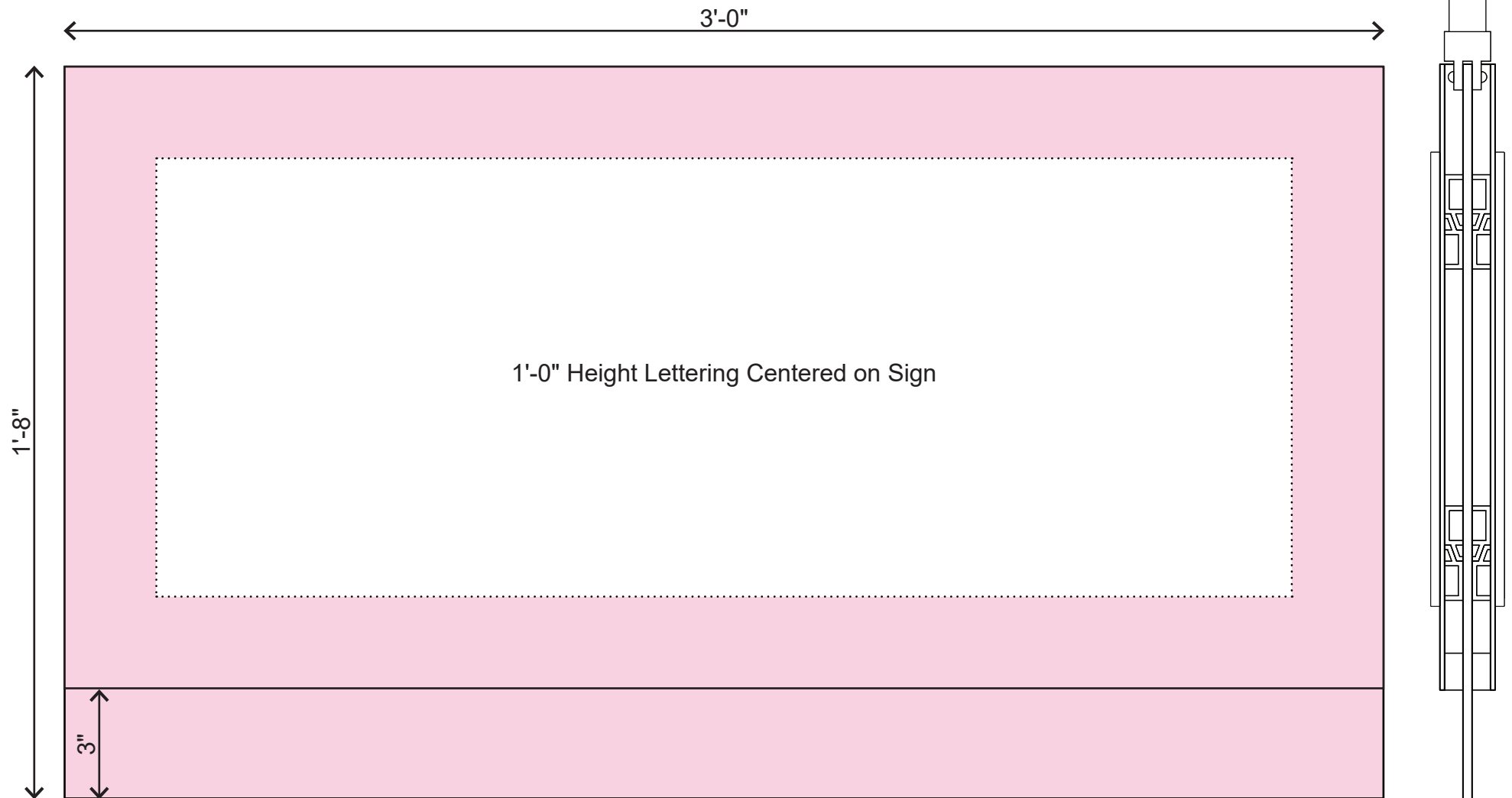

T-C1 SYMBOL ID - FLAG MOUNTED

Flag mounted identification signs, to help passengers find their way to restrooms and similar services like nursing room and service animal relief area.

Construction Notes:

1. Double faced, wall mounted fabricated aluminum sign with LED accent light.
2. Fabricated sign cabinet with internal framing as required.
3. Sign panel to be fabricated aluminum with paint as noted.
4. Pictograms to be flat-cut out 1/4" thick aluminum painted in colors as noted. Pictograms to be mounted to sign panel with hidden mechanical fasteners.
5. Designer to field verify and determine best method of installation with minimal visual impact. Designer to provide structural engineering calculations as required and coordinate with general contractor for structural requirements.
6. Field verify existing conditions.

Note: The scale of signage and graphics is subject to change in order to be compliant with ADA guidelines.

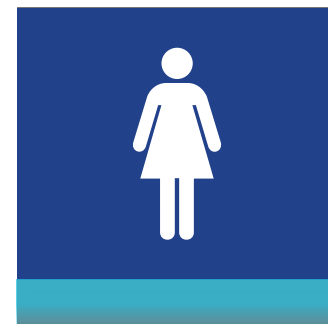
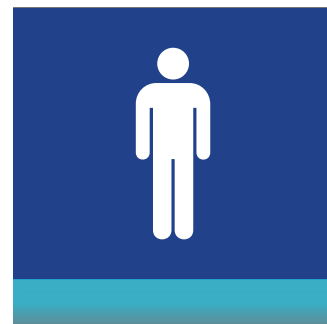
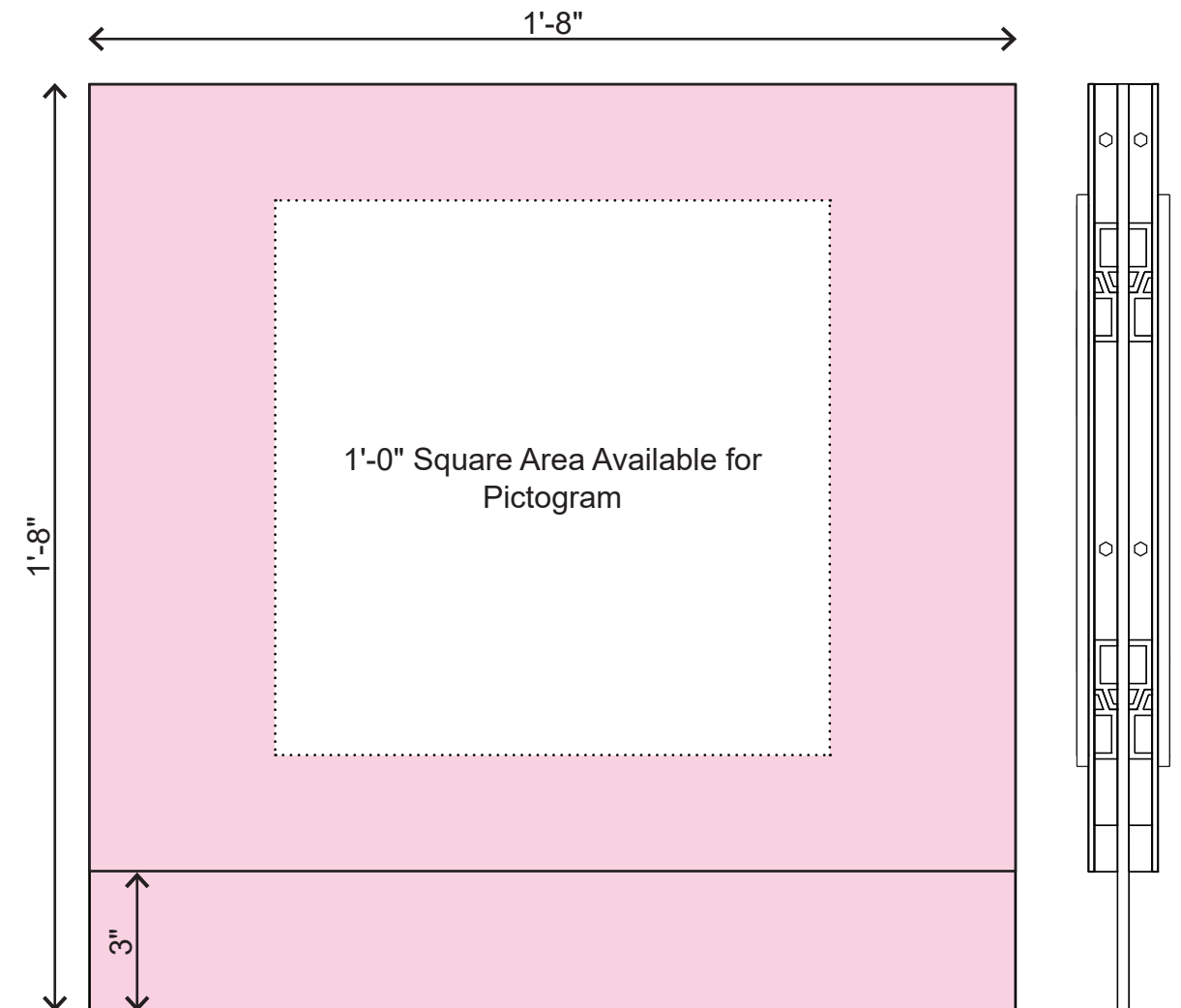

T-C2 SYMBOL ID - WALL MOUNTED

Wall mounted identification signs, to help passengers find their way to restrooms and similar services like nursing room and service animal relief area.

Construction Notes:

1. Single faced, wall mounted fabricated aluminum sign with LED accent light.
2. Fabricated sign cabinet with internal framing as required.
3. Sign panel to be fabricated aluminum with paint as noted.
4. Pictograms to be flat-cut out 1/4" thick aluminum painted in colors as noted. Pictograms to be mounted to sign panel with hidden mechanical fasteners.
5. Designer to field verify and determine best method of installation with minimal visual impact. Designer to provide structural engineering calculations as required and coordinate with general contractor for structural requirements.
6. Field verify existing conditions.

Note: The scale of signage and graphics is subject to change in order to be compliant with ADA guidelines.

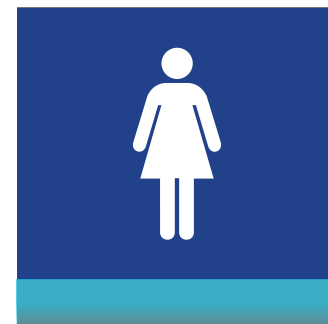
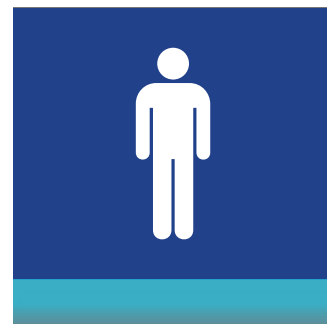
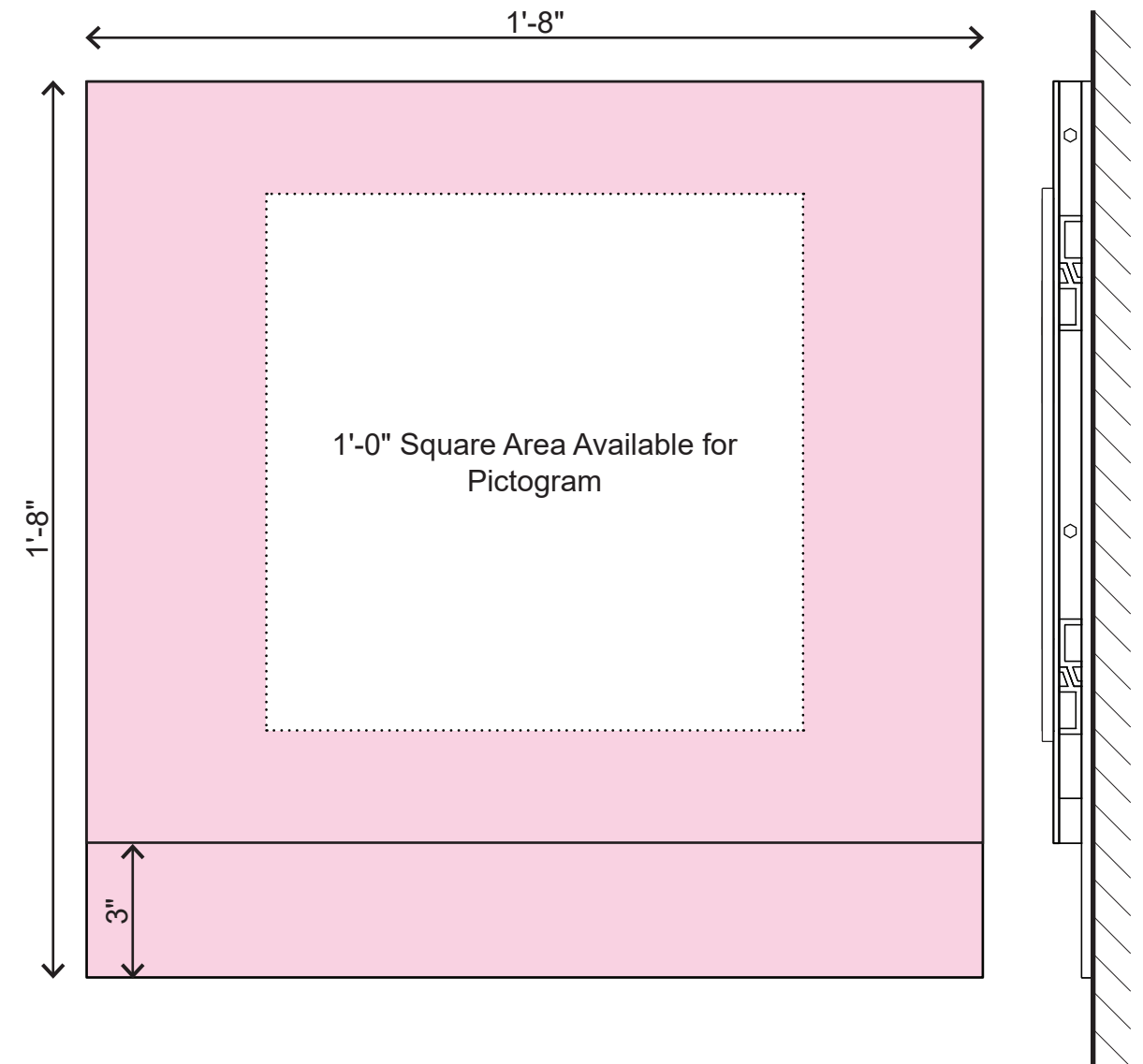

T-D1 FREESTANDING PYLON

Freestanding pylon sign in the terminal to guide passengers to their desired gates.

Construction Notes:

1. Double-faced, freestanding pylon sign with replaceable, illuminated map directory, or LED Display depending on ONT requirements.
2. Fabricated aluminum cabinet with internal structure as required.
3. Sign panel to be fabricated aluminum with paint as noted.
4. Copy and graphics to be vinyl die cut in colors indicated.
5. When required, LED Display specifications to be approved by ONT. Provide manufacturer's requirements for ventilation in sign cabinet. Allow for ease of maintenance with inconspicuous access panels.
6. Designer to field verify and determine best method of installation with minimal visual impact. Designer to provide structural engineering calculations as required and coordinate with general contractor for structural requirements.
7. Field verify existing conditions.

Note: The scale of signage and graphics is subject to change in order to be compliant with ADA guidelines.

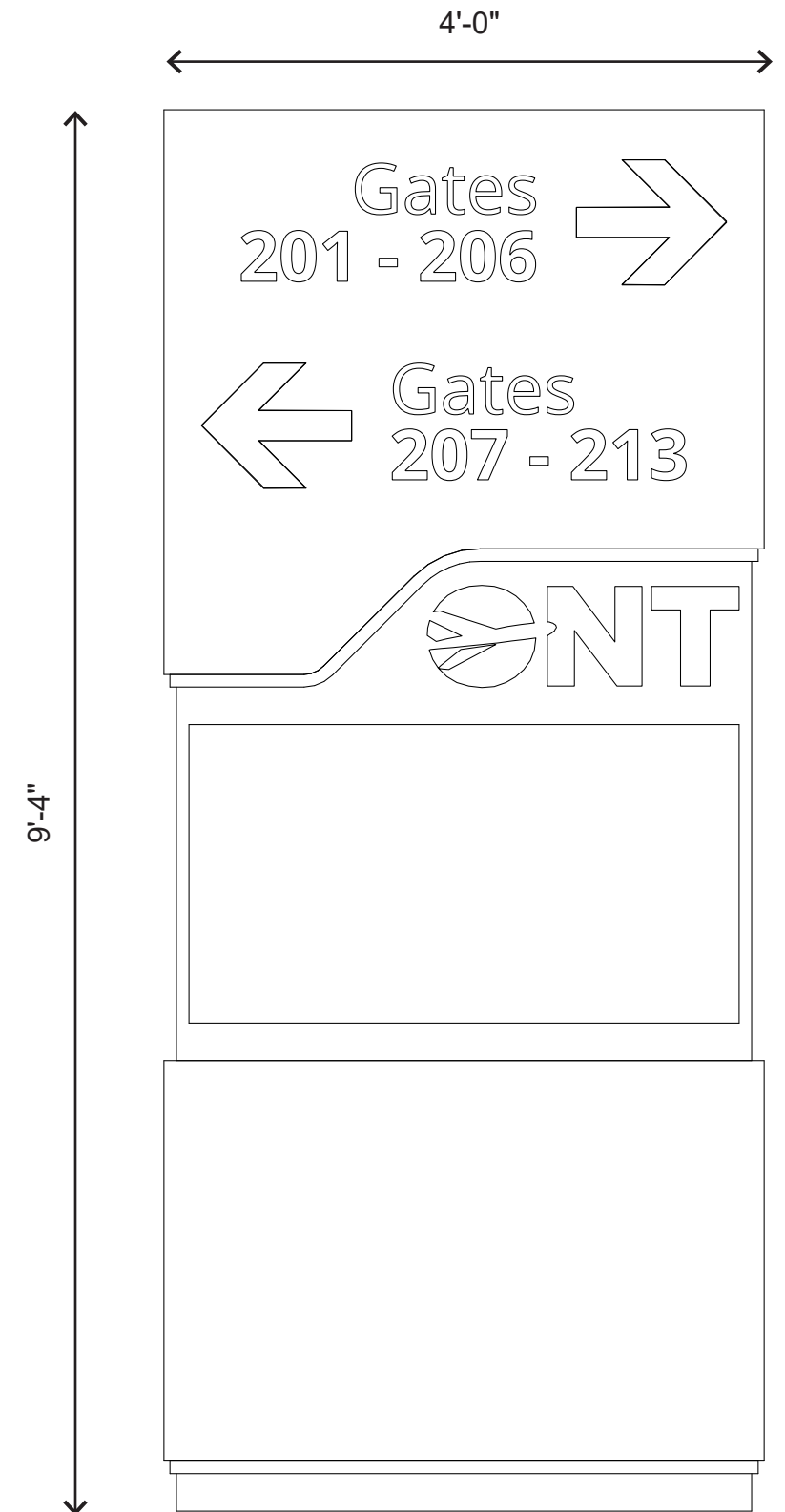

T-E1 ELEVATOR ID - WALL MOUNTED

Wall mounted identification signs, to help passengers identify elevators in the terminal.

Construction Notes:

1. Single faced, wall mounted fabricated aluminum sign with LED accent light.
2. Fabricated sign cabinet with internal framing as required.
3. Sign panel to be fabricated aluminum with paint as noted.
4. Pictograms to be flat-cut out 1/4" thick aluminum painted in colors as noted. Pictograms to be mounted to sign panel with hidden mechanical fasteners.
5. Designer to field verify and determine best method of installation with minimal visual impact. Designer to provide structural engineering calculations as required and coordinate with general contractor for structural requirements.
6. Field verify existing conditions.

Note: The scale of signage and graphics is subject to change in order to be compliant with ADA guidelines.

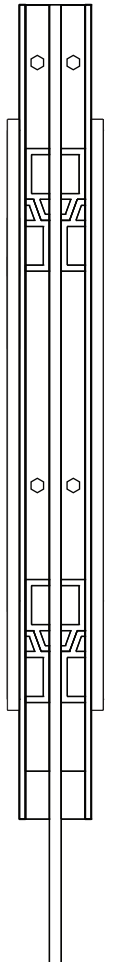
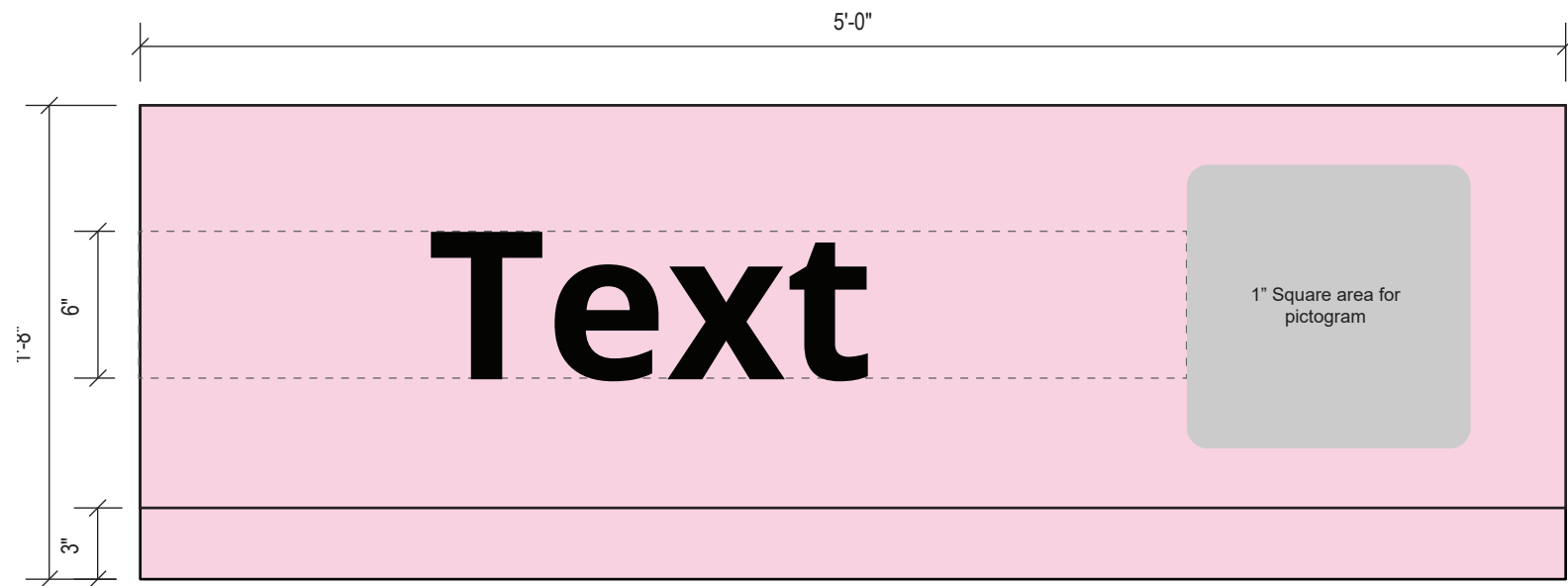

T-F1 OVERHEAD DIRECTIONAL SMALL - CEILING MOUNTED

Ceiling mounted signs to help passengers find their way to elevators in the terminal.

Construction Notes:

1. Double faced, ceiling mounted fabricated aluminum sign with LED accent light.
2. Fabricated sign cabinet with internal framing as required.
3. Sign panel to be fabricated aluminum with paint as noted
4. Pictograms to be flat-cut out 1/4" thick aluminum painted in colors as noted. Pictograms to be mounted to sign panel with hidden mechanical fasteners.
5. Designer to field verify and determine best method of installation with minimal visual impact. Designer to provide structural engineering calculations as required and coordinate with general contractor for structural requirements.
6. Field verify existing conditions.
7. Vertical supports and bracket with decorative cladding as required. Provide smallest diameter as allowed by structural engineering calculations.

Note: The scale of signage and graphics is subject to change in order to be compliant with ADA guidelines.

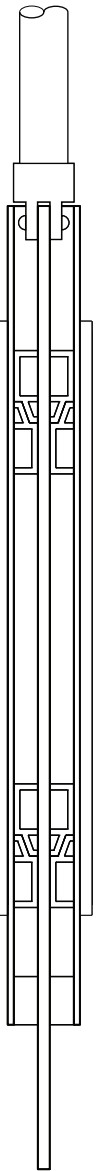
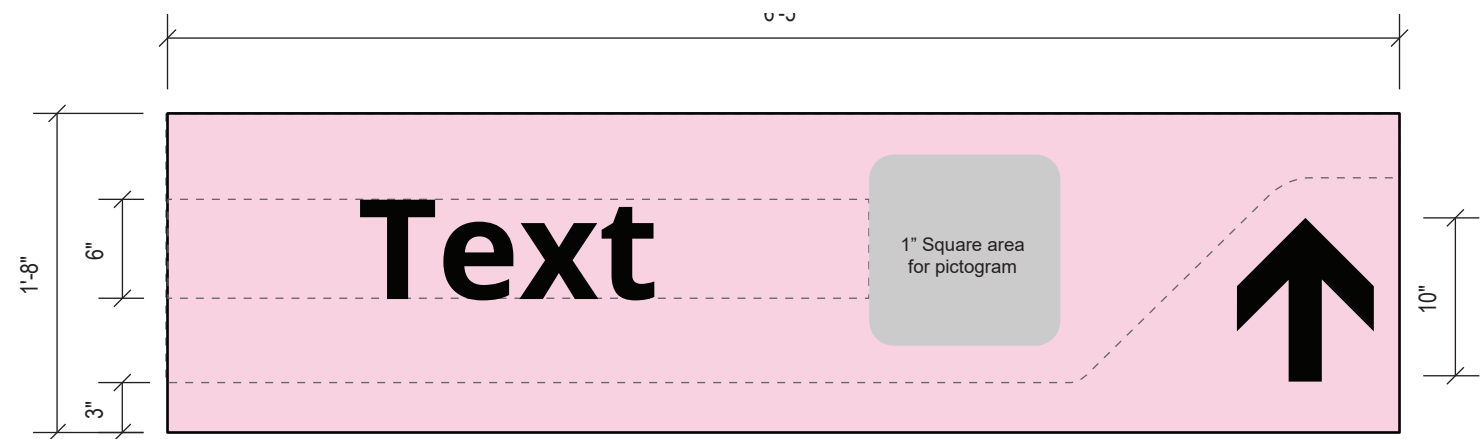

T-G1 ROOM IDENTIFICATION SIGN

Wall mounted ADA sign panel with window for changeable paper inserts, optional window sign with changeable insert to be added on door as needed by facility.

Construction Notes:

1. 1/8" painted acrylic sign panel in colors as indicated.
2. Tactile letters and grade 2 braille to comply with local codes and ADA requirements, fabricator to confirm as required.
3. Optional window sign with changeable inserts. OIAA to confirm locations as needed with room identification.
4. Sign to be mounted on wall with VHB tape and adhesive as required.
5. Designer to field verify and determine best method of installation with minimal visual impact. Designer to provide structural engineering calculations as required and coordinate with general contractor for structural requirements.
6. Field verify existing conditions.

Note: The scale of signage and graphics is subject to change in order to be compliant with ADA guidelines.

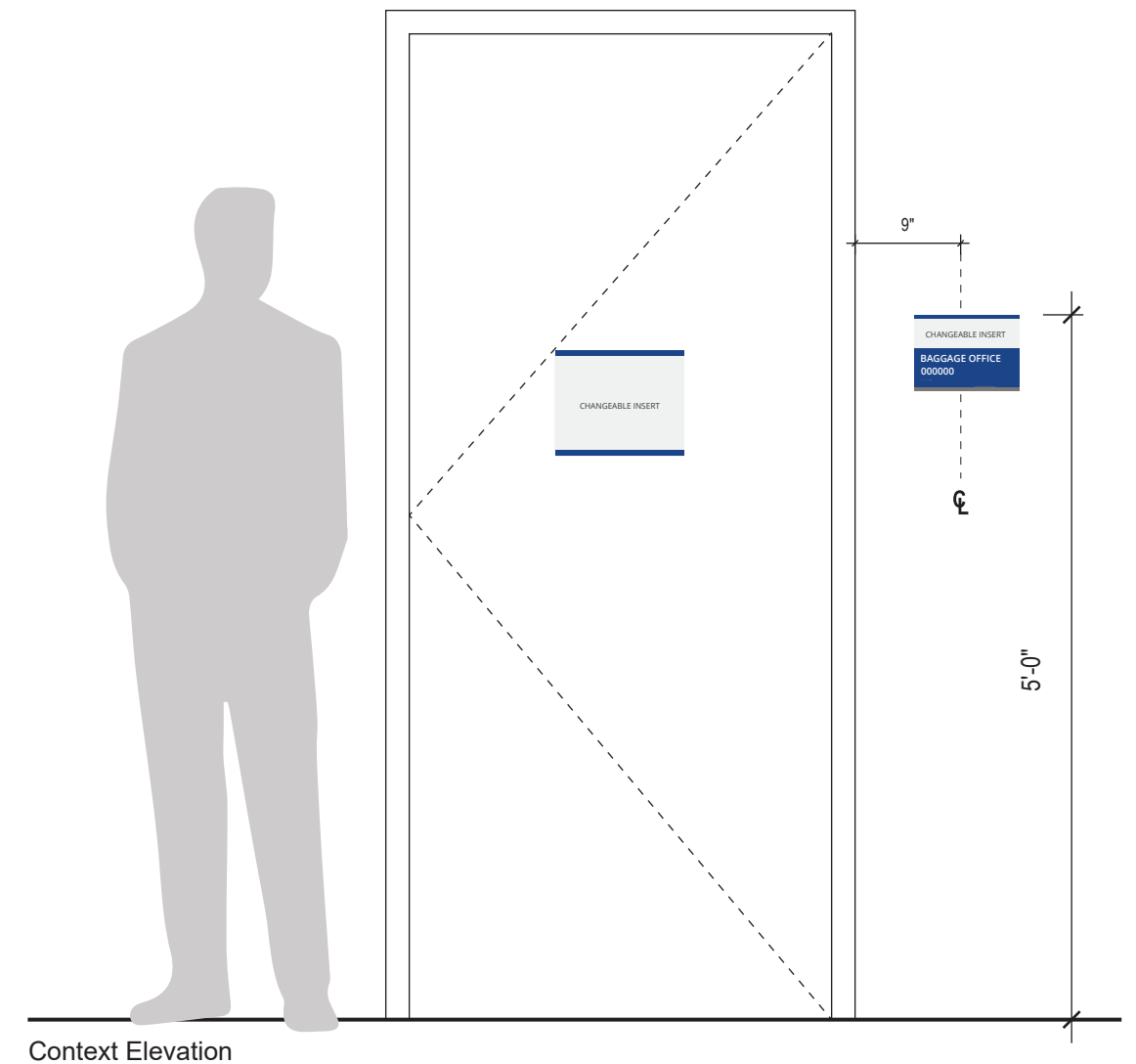
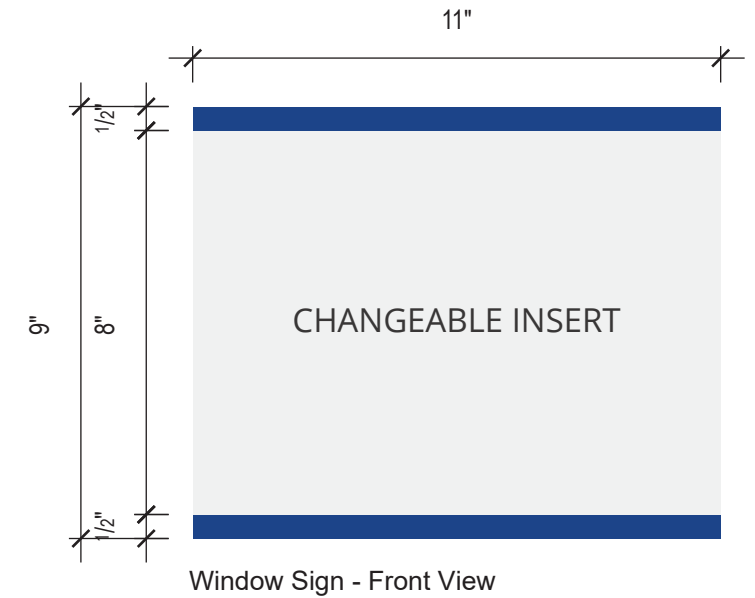
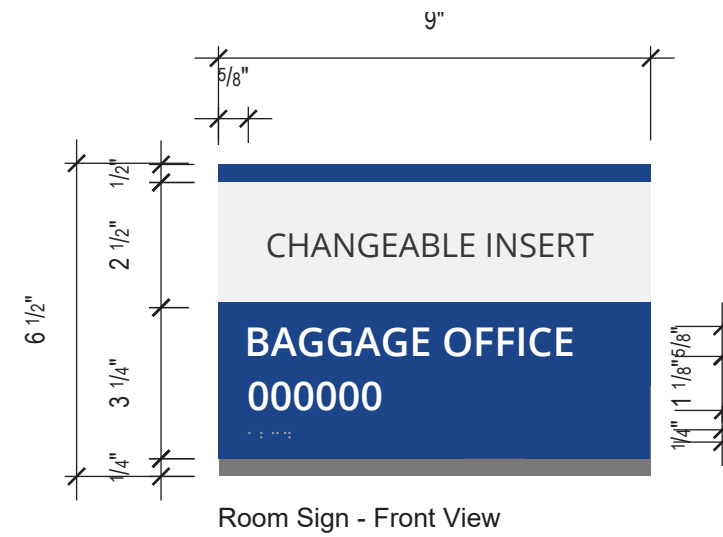

T-G2 RESTROOM IDENTIFICATION SIGN

Wall mounted ADA sign panel to identify restrooms.

Construction Notes:

1. 1/8" painted acrylic sign panel in colors as indicated.
2. Tactile letters and grade 2 braille to comply with local codes and ADA requirements, fabricator to confirm as required.
3. Sign to be mounted on wall with VHB tape and adhesive as required.
4. Designer to field verify and determine best method of installation with minimal visual impact. Designer to provide structural engineering calculations as required and coordinate with general contractor for structural requirements.
5. Field verify existing conditions.

Note: The scale of signage and graphics is subject to change in order to be compliant with ADA guidelines.

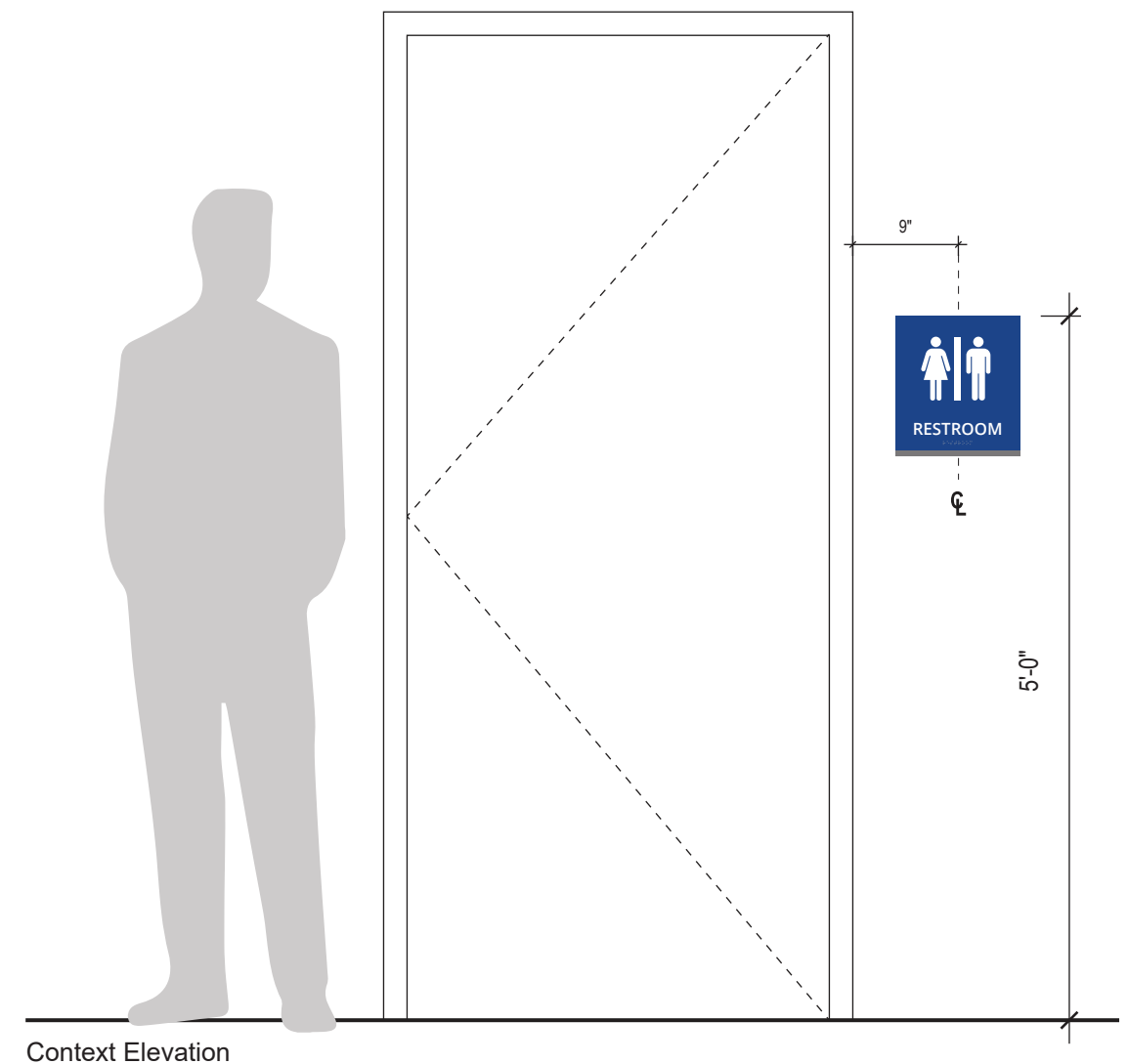
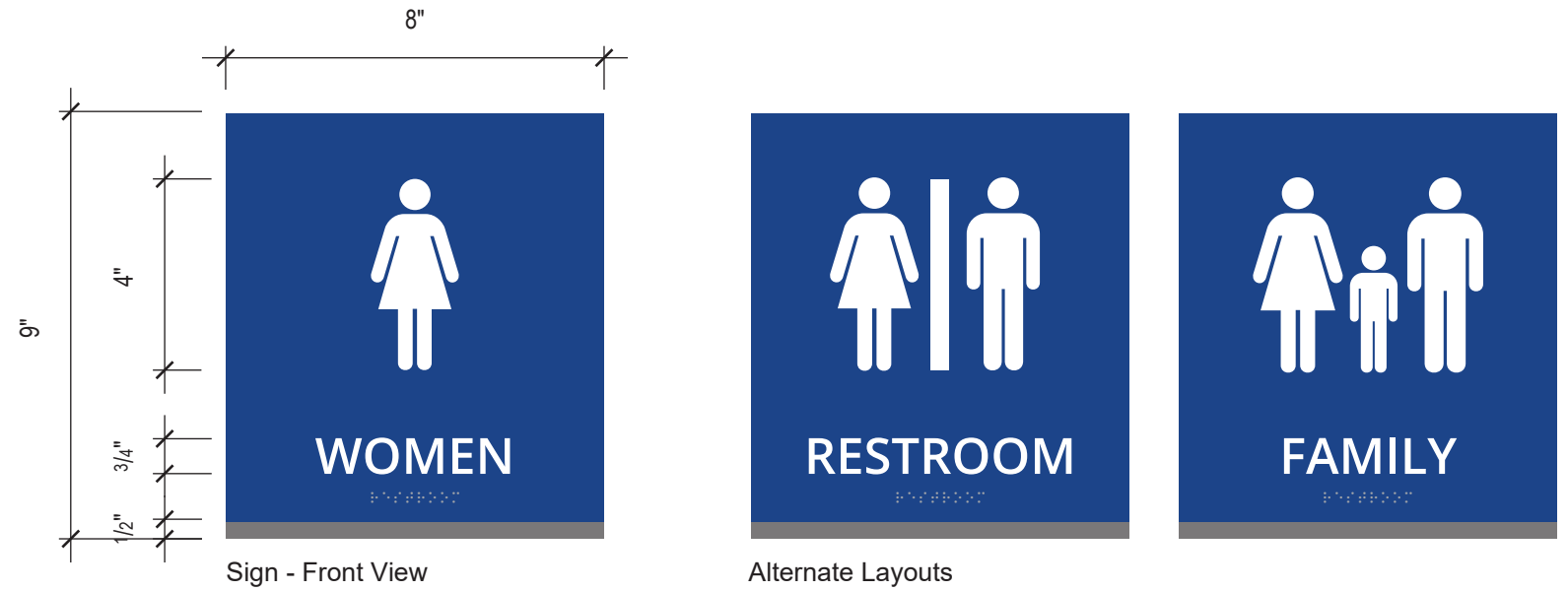

T-G3 DOOR IDENTIFICATION SIGN

Door mounted sign panel to identify door number.

Construction Notes:

1. 1/8" painted acrylic sign panel in colors as indicated.
2. Copy to be die cut vinyl in colors as indicated.
3. Sign to be mounted on door as shown with VHB tape and adhesive as required.
4. Designer to field verify and determine door dimensions and best method of installation with minimal visual impact. Designer to provide structural engineering calculations as required and coordinate with general contractor for structural requirements.
5. Field verify existing conditions.

Note: The scale of signage and graphics is subject to change in order to be compliant with ADA guidelines.

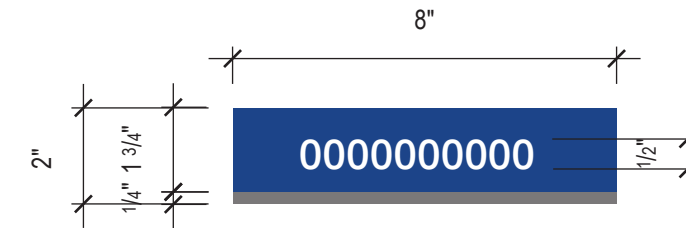

Front View

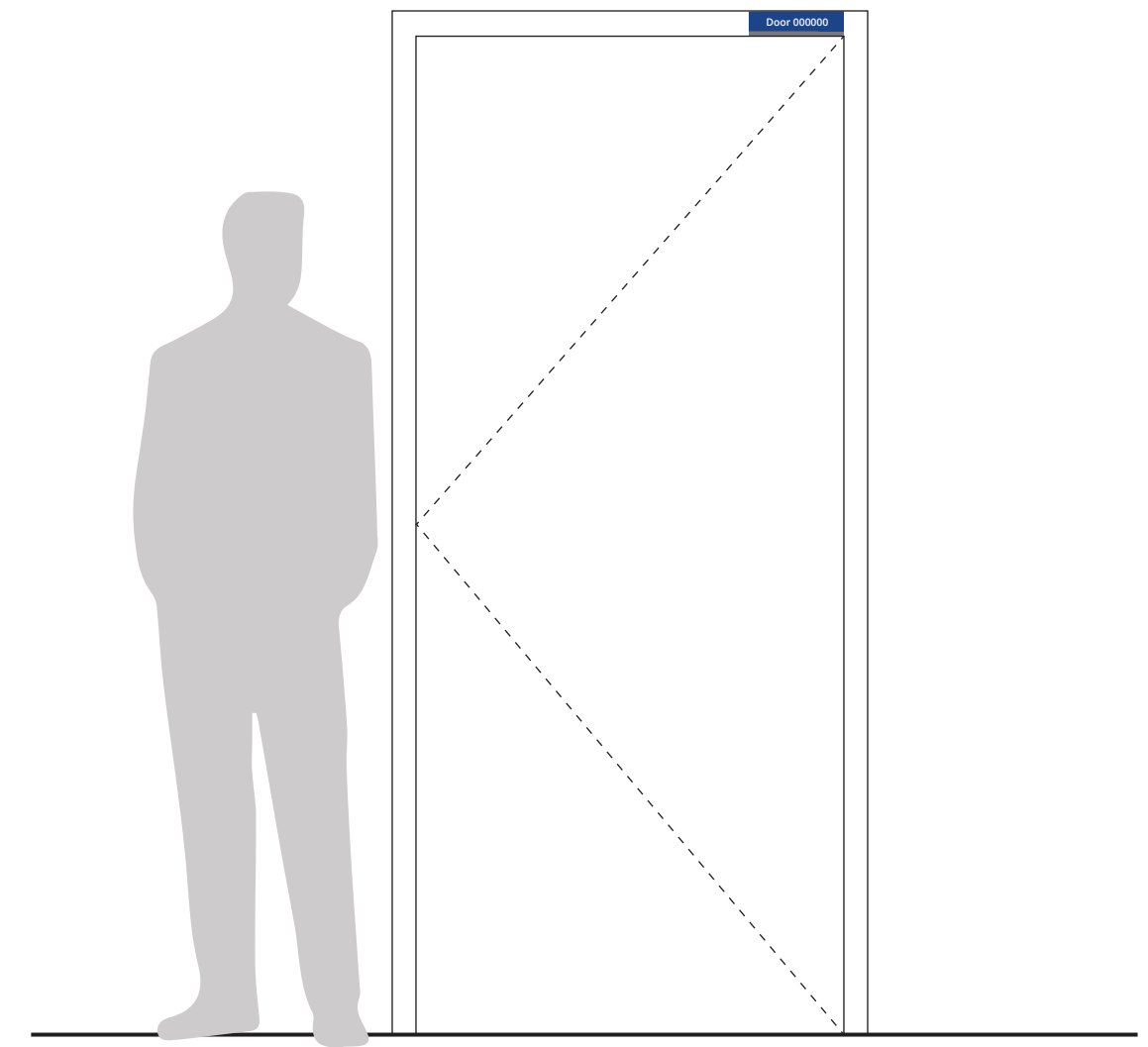

Context Elevation

T-G4 AUTHORIZED PERSONNEL ONLY SIGN

Door mounted vinyl sign to identify restricted areas for use by authorized airport personnel.

Construction Notes:

1. Direct printed vinyl graphic in colors as indicated.
2. Sign to be applied centered on door as shown in drawing.
3. Designer to field verify and determine door dimensions and best method of installation with minimal visual impact.
4. Field verify existing conditions.

Note: The scale of signage and graphics is subject to change in order to be compliant with ADA guidelines.

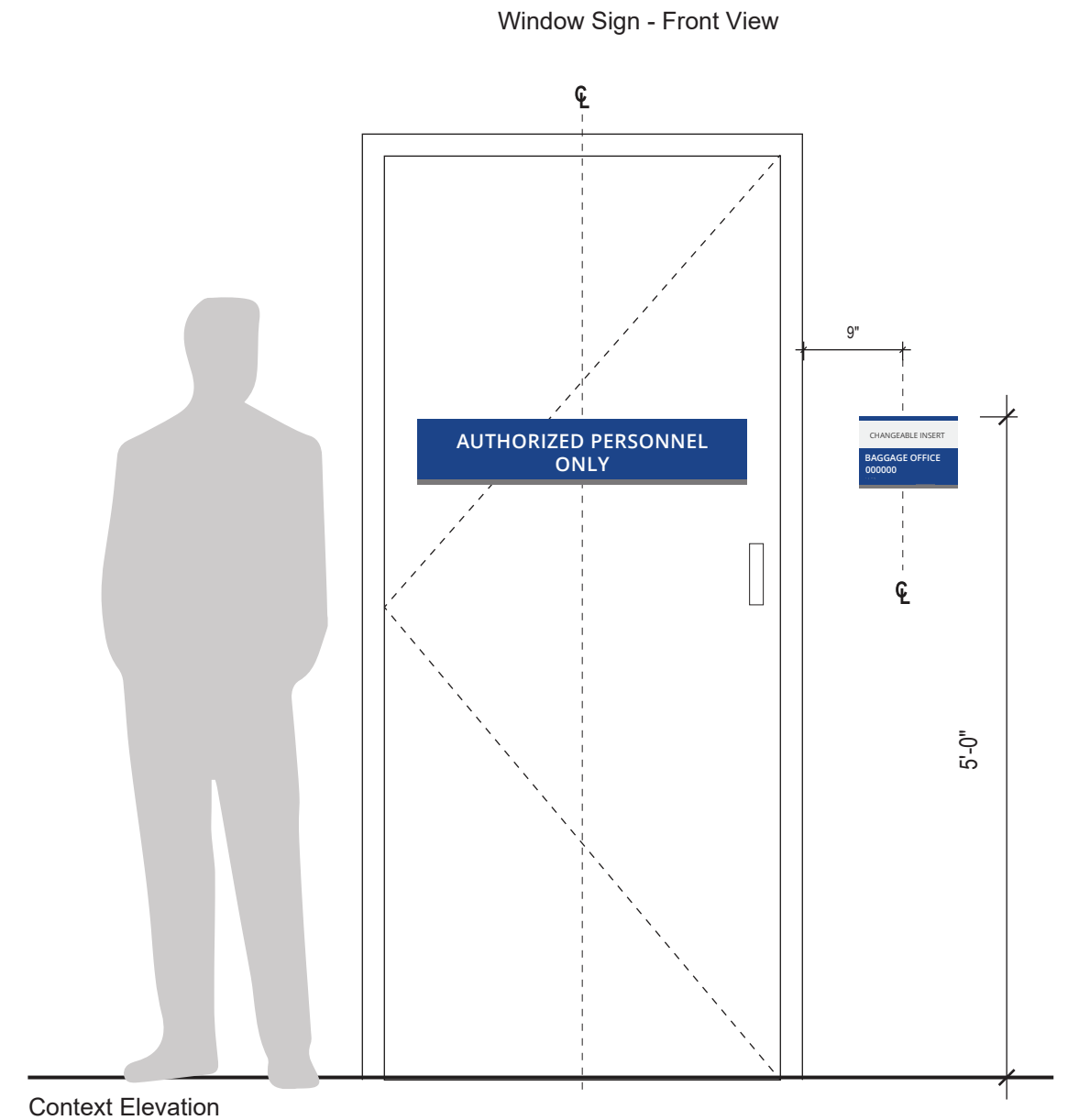

T-H1 BUILDING IDENTIFICATION CHANNEL LETTERS

Dimensional letters to help identify a facility.

Construction Notes:

1. Internally illuminated 6" Deep channel letters mechanically attached to a baseplate anchored to existing exterior canopy structure.
2. Applied perforated dark blue vinyl film and dark blue painted returns, colors to be approved by ONT.
3. Designer to field verify and determine best method of installation with minimal visual impact. Designer to provide structural engineering calculations as required and coordinate with general contractor for structural and electrical requirements.
4. Field verify existing conditions.

Note: The scale of signage and graphics is subject to change in order to be compliant with ADA guidelines.

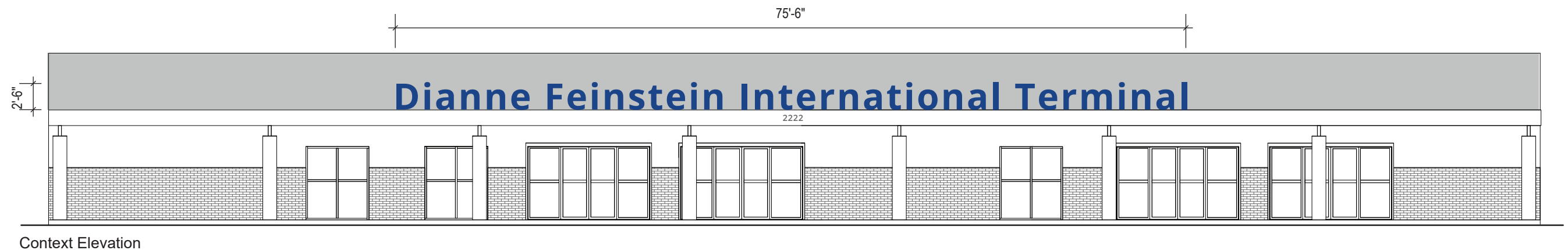

T-H1 BUILDING IDENTIFICATION CHANNEL LETTERS



T-H1 - Building ID Letters
International Arrivals Facility

T-H2 BUILDING ADDRESS DIMENSIONAL LETTERS

Dimensional letters on a building, to help identify building address.

Construction Notes:

1. 1/2" thick painted acrylic letters mounted on building with concealed mechanical fasteners.
2. Returns to be painted on all sides with dark blue color, ONT to confirm.
3. Designer to field verify and determine best method of installation with minimal visual impact. Designer to coordinate with general contractor for structural requirements.
4. Field verify existing conditions.

Note: The scale of signage and graphics is subject to change in order to be compliant with ADA guidelines.

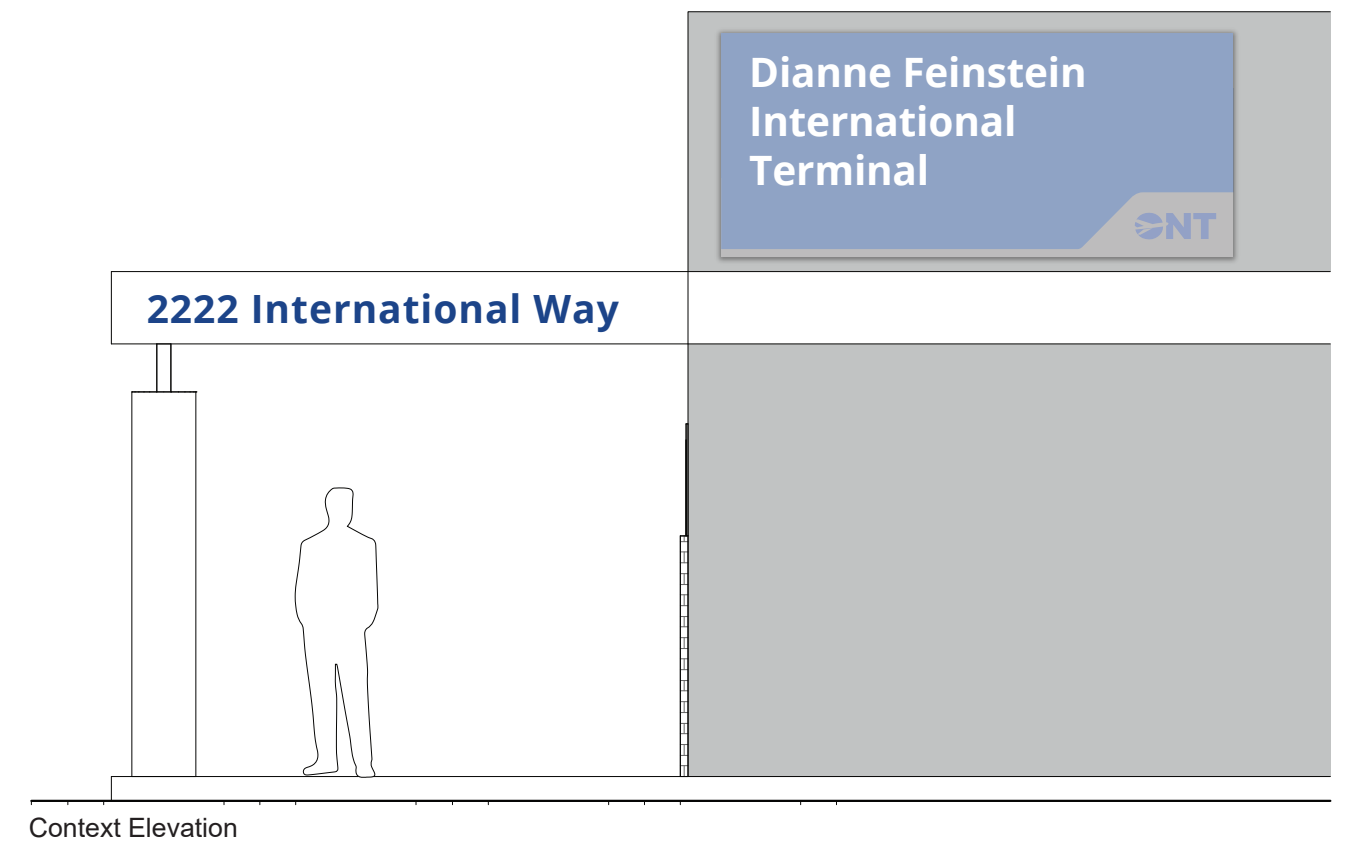
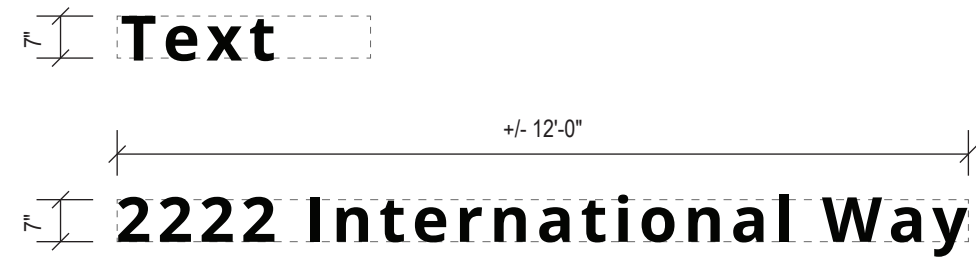

T-J1 BUILDING IDENTIFICATION SIGN

Building mounted identification signs to help identify various buildings on airport campus.

Construction Notes:

1. Single faced, 4" wall mounted fabricated aluminum sign.
2. Fabricated sign cabinet with internal framing as required.
3. Sign panel to be fabricated aluminum with paint as noted.
4. Copy and graphics to be reflective vinyl die cut in colors indicated.
5. Designer to field verify and determine best method of installation with minimal visual impact. Fabricator to provide structural engineering calculations as required and coordinate with general contractor for structural requirements.
6. Field verify existing conditions.
7. Supports and brackets as required. Provide smallest diameter as allowed by structural engineering calculations.

Note: The scale of signage and graphics is subject to change in order to be compliant with ADA guidelines.

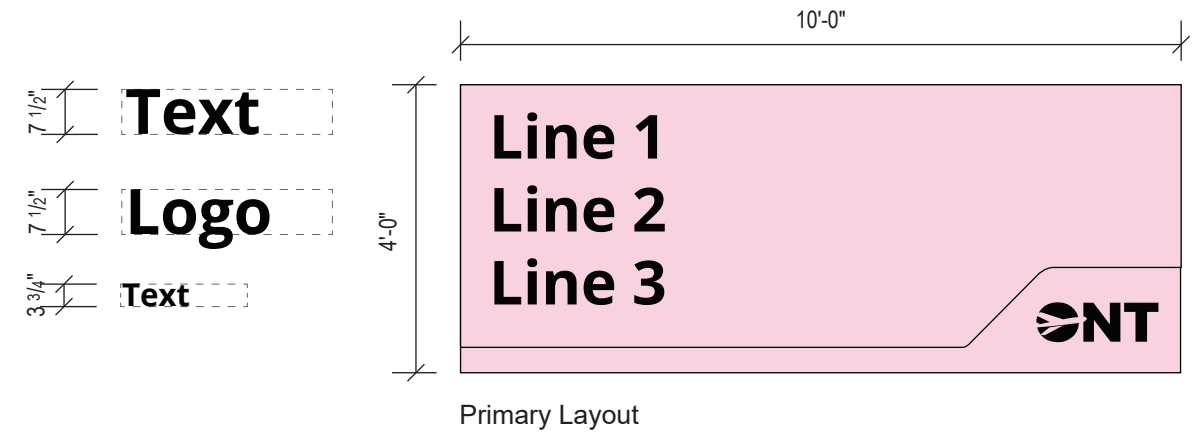

Side View

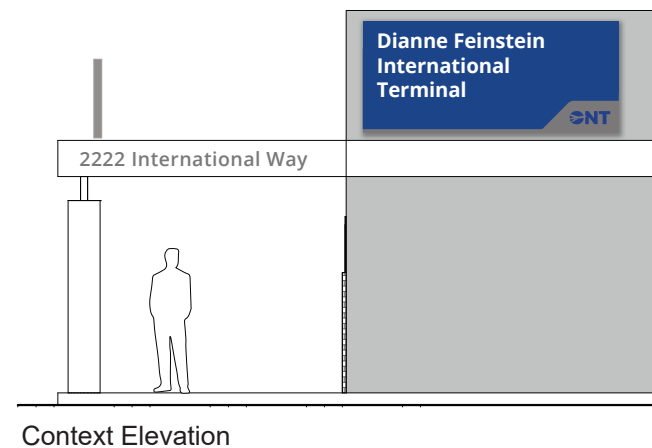

T-J1 BUILDING IDENTIFICATION SIGN



T-H2 - Building Address Letters

T-J1 - Building ID Sign

International Arrivals Facility

INTERIOR | CHECK IN BACKWALL

Please see general requirements for image & text size, colors & fonts, and materials. Additionally, requirements are outlined below.

Description

Tenant corporate signature signs may be displayed on the wall behind the check in desk. Non-standard sign types, (e.g., edge-lit or back washed illumination) as well as wall treatments (subdued graphics, wall textures) are acceptable with approval.

Location

The signature sign will be centered vertically over the check in desk on the wall directly behind the check in desk.

Sign Size

The total length will not exceed 75% of the length of the lease line.

Image & Text Size

The preferred sign is an individually mounted dimensional tenant corporate signature with a logo/logotype maximum height of 18 inches.

Quantity

One (1) sign is permitted for each 25 feet of the lease line.

Common Use

Tenants should anticipate Common Use digital signage applications to be integrated into the Check In Hall to be developed in the near future.

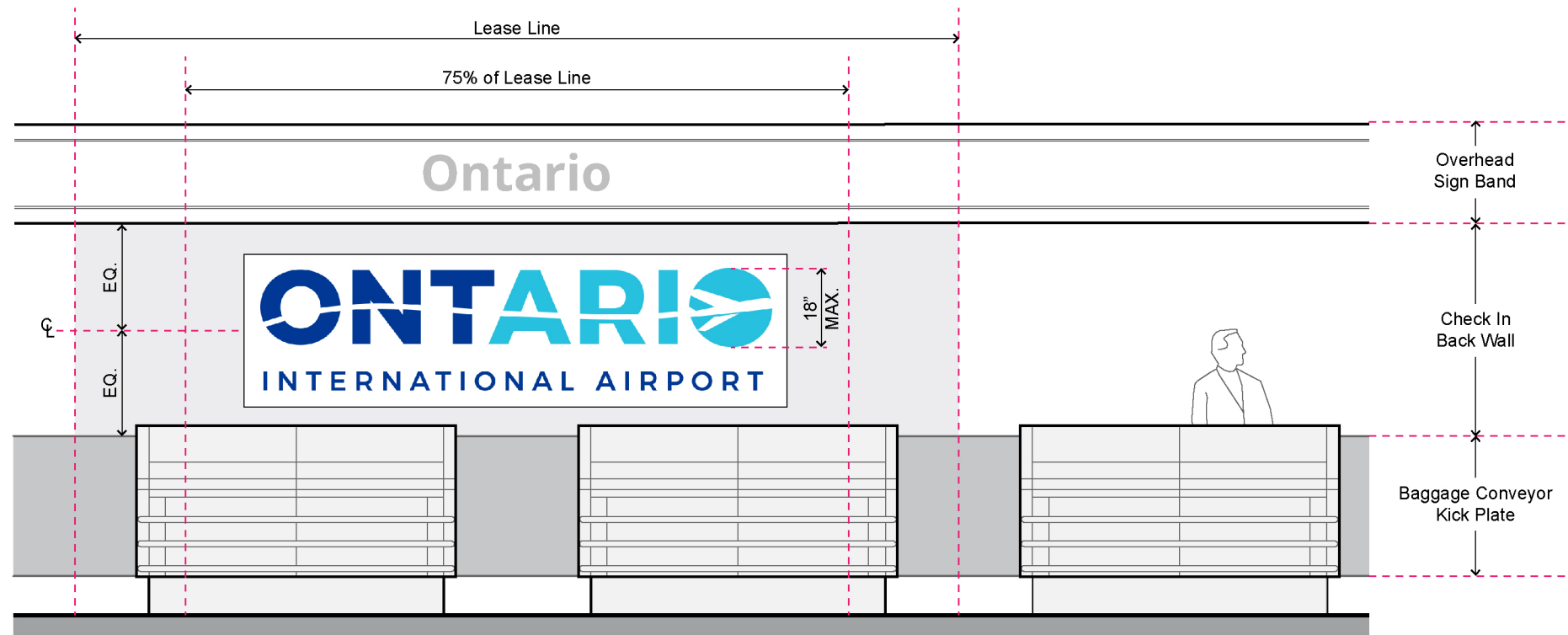

X No Permanent Banners, Temporary banners are permissible with prior OIAA Approval



X No Branding will be allowed on the Overhead Sign Band



? Attachments, temporary or otherwise are permissible with prior OIAA Approval See Temporary Signage Section

INTERIOR | CHECK IN DESK

Please see general requirements for image & text size, colors & fonts, and materials. Additionally, requirements are outlined below.

Description

Display signs consisting of the tenant's corporate signature and accompanying informational text will be permitted on check in desk. OIAA will establish a start and end date for display signs.

Location

Display signs will be displayed on check in desk counters only. No display signs will be permitted on—or attached to—other surfaces including ticket kiosks, conveyor systems, housings, stanchions or structures.

Sign Size

Maximum dimensions are 8.5 inches by 11 inches.

Materials

Acceptable material is acrylic frame with insert or window with metal or plastic support. Temporary signage adhered via tape or another adhesive not acceptable.

Quantity

One (1) sign is permitted per counter position.



X No Attachments to the Check In Counter, temporary or otherwise



? Temporary Airline Initiatives are permissible with prior OIAA Approval See Temporary Signage Section

INTERIOR | QUEUE

Please see general requirements for image & text size, colors & fonts, and materials. Additionally, requirements are outlined below.

Description

Queue area signs are permissible on queue ribbons and stanchion toppers in tenant leased spaces only.

Location

Stanchion top signs will be framed and firmly attached to the stanchion post top only. No queue area signs will be permitted on—or attached to—other surfaces including floors, walls, structural supports, columns, and ceilings.

Copy on queue ribbons will be printed graphics of one piece with the tape material. No signs will be attached to the ribbon.

Sign Size

Frame dimensions are a maximum of 11 inches wide by 14 inches high.

The corporate signature height will fit comfortably on the ribbon.

Image & Text Size

The corporate signature and accompanying text will fit comfortably within a panel sign.

Materials

Standard frame as provided by manufacturer.

Screened copy on ribbon fabric.

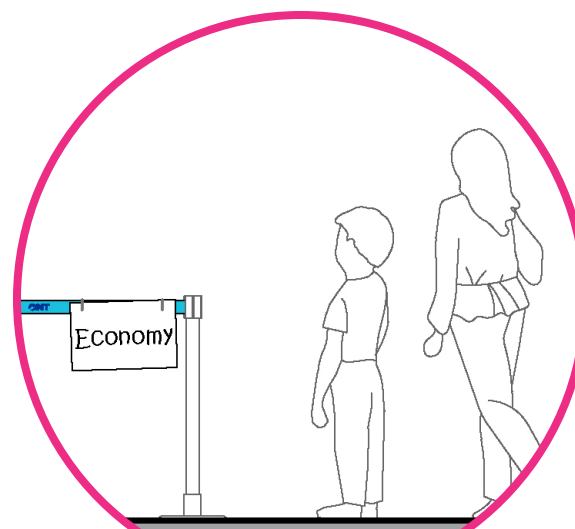
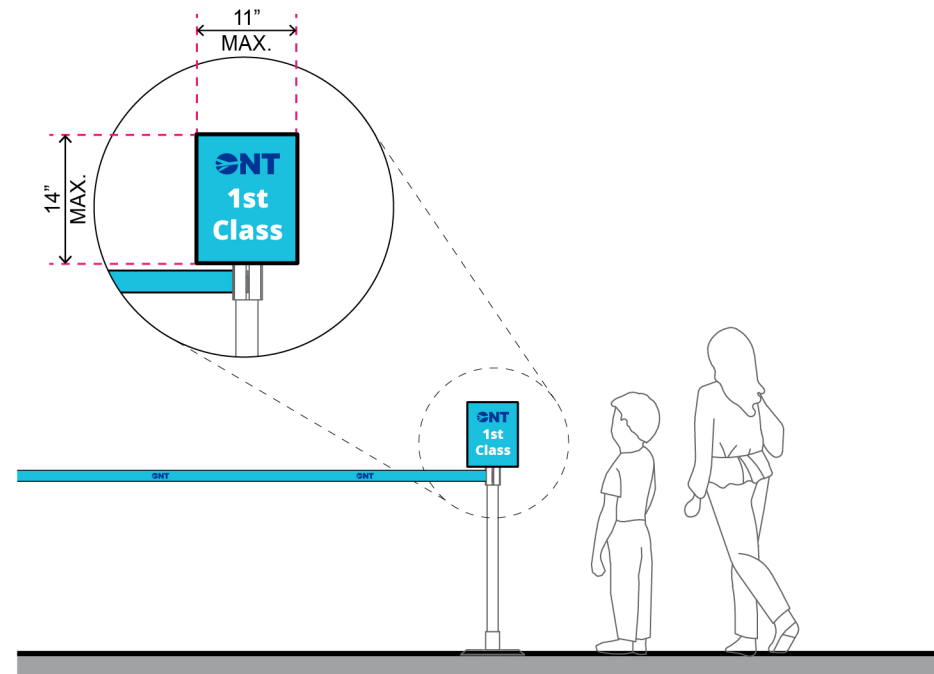

X No Attachments to the Queue Ribbon, temporary or otherwise

INTERIOR | PYLONS

Please see general requirements for image & text size, colors & fonts, and materials. Additionally, requirements are outlined below.

Description

Pylon signs consisting of the tenant's corporate signature and accompanying informational text will be permitted within the check in hall. Pylons will be weighted but not attached to the floor.

Location

Pylon signs will be displayed within tenant queue areas only. Public circulation through the check in hall must be maintained.

The number of pylons and the spacing of pylons are subject to periodic review by OIAA to ensure visibility and circulation within the Check In Hall is maintained.

Sign Size

Pylon dimensions are a maximum of 3 feet wide by 7 feet tall.

Materials

Standard frame as provided by manufacturer.

Common Use

Tenants should anticipate Common Use digital signage applications to be integrated into the Check In Hall to be developed in the near future.

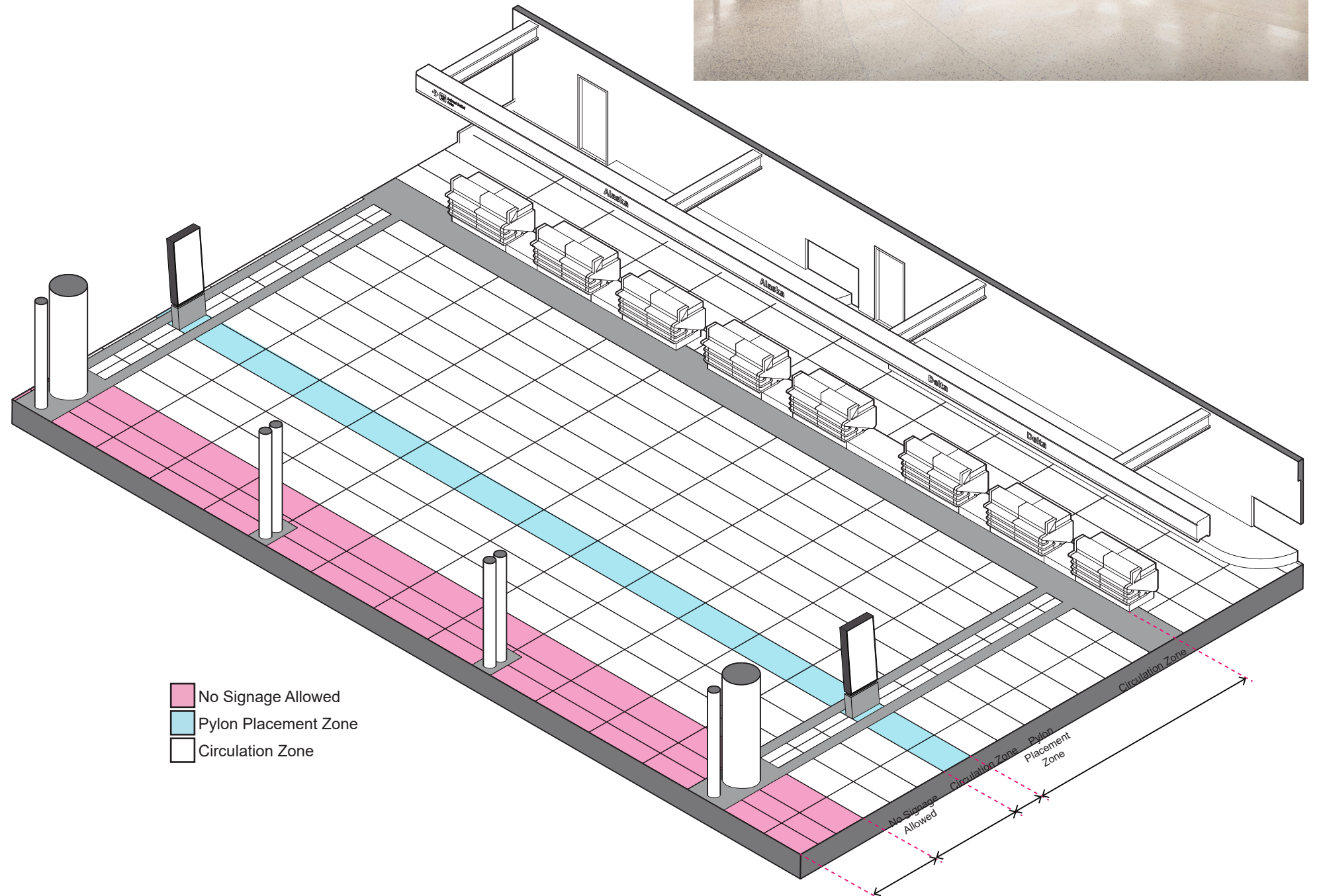

INTERIOR | GATE COUNTER BACKWALL

Please see general requirements for image & text size, colors & fonts, and materials. Additionally, requirements are outlined below.

Description

Tenant signature and informational signs are permitted on the gate counter backwall within the provided back lit displays. These signs will be reviewed and approved by OIAA on a case-by-case basis. All signs will be of an informative nature designed to meet the needs of the traveling public. No promotional or advertising copy or graphics will be allowed.

Fixed signage will be permitted instead of the back lit display, as long as the signage does not extend beyond the intended back lit display area. A fixed sign will be either screened or vinyl copy applied to an acrylic panel or other existing substrate. These signs will be reviewed and approved by OIAA on a case-by-case basis.

If flight schedule monitors are provided by OIAA, electronic message displays will be controlled remotely from each gate podium by the airline agents.

Location

Signs are permitted within the center panel of the OIAA provided gate counter backwall.

Sign Size

Determined by the back lit displays.

Image & Text Size

Image and text sizes will be determined by the monitor's capabilities.

Copy may consist of a corporate signature and flight information only.

Materials

Determined by the back lit displays.

Quantity

One (1) display sign per service position.

Common Use

Tenants should anticipate Common Use digital signage applications to be integrated into the Concourse Gate Areas in the near future.

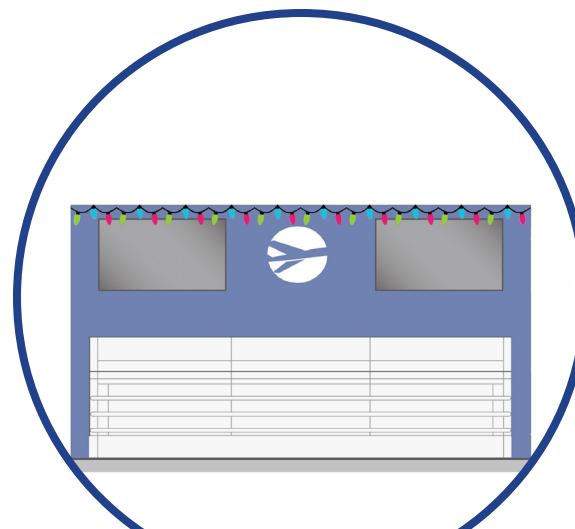
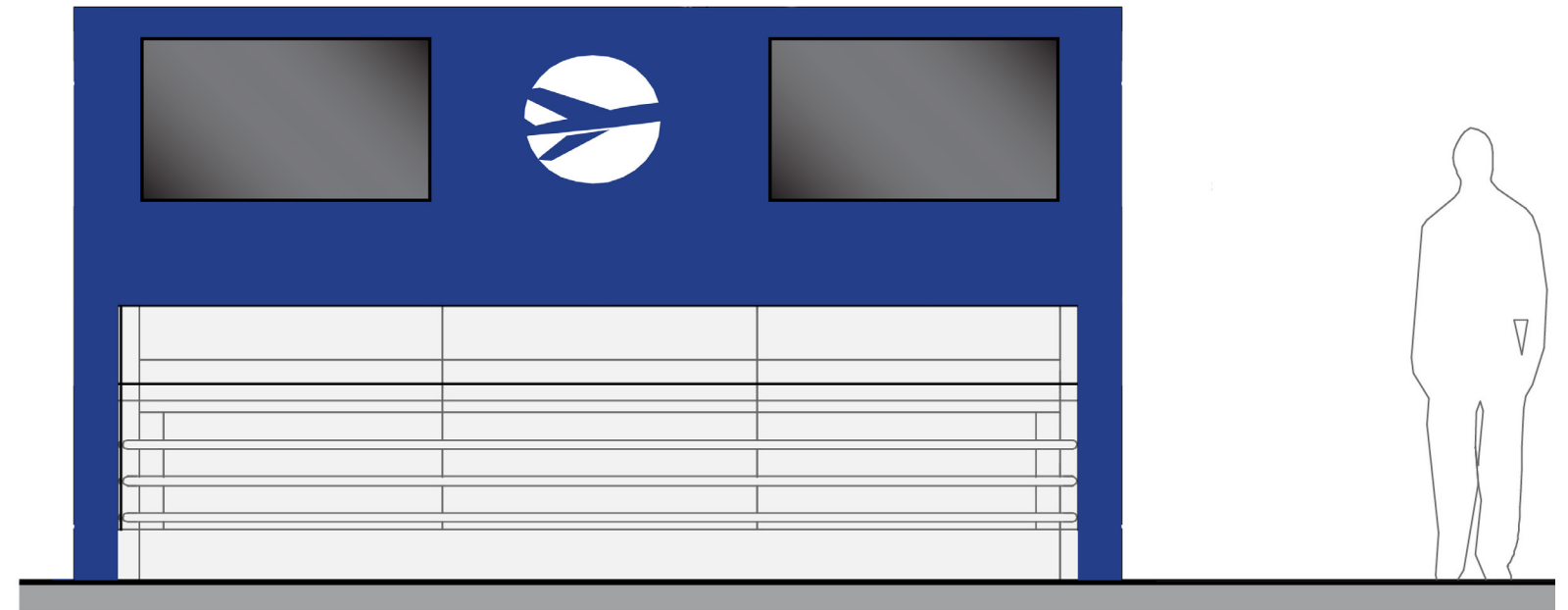

? Attachments to the Gate Counter are permissible with prior OIAA Approval See Temporary Signage Section

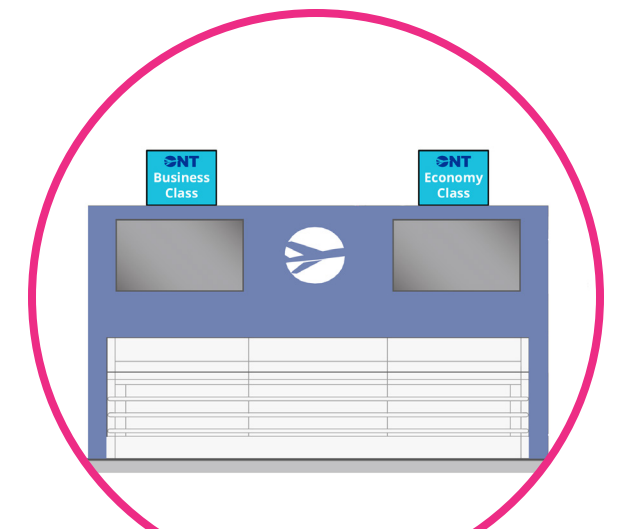

X No additional signage on top of Gate Counter Backwall

INTERIOR | GATE COUNTER

Please see general requirements for image & text size, colors & fonts, and materials. Additionally, requirements are outlined below.

Description

Display signs consisting of the tenant's corporate signature and accompanying informational text will be permitted on gate counters. OIAA will establish a start and end date for display signs.

Location

Display signs will be displayed on gate counters only. No display signs will be permitted on—or attached to—other surfaces including ticket kiosks, conveyor systems, housings, stanchions or structures.

Sign Size

Maximum dimensions are 8.5 inches by 11 inches.

Materials

Acceptable material is acrylic frame with insert or window with metal or plastic support. Temporary signage adhered via tape or another adhesive not acceptable.

Quantity

One (1) sign is permitted per counter position.

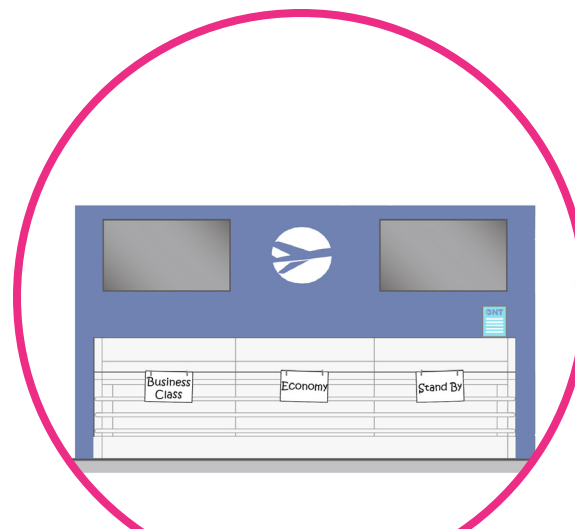
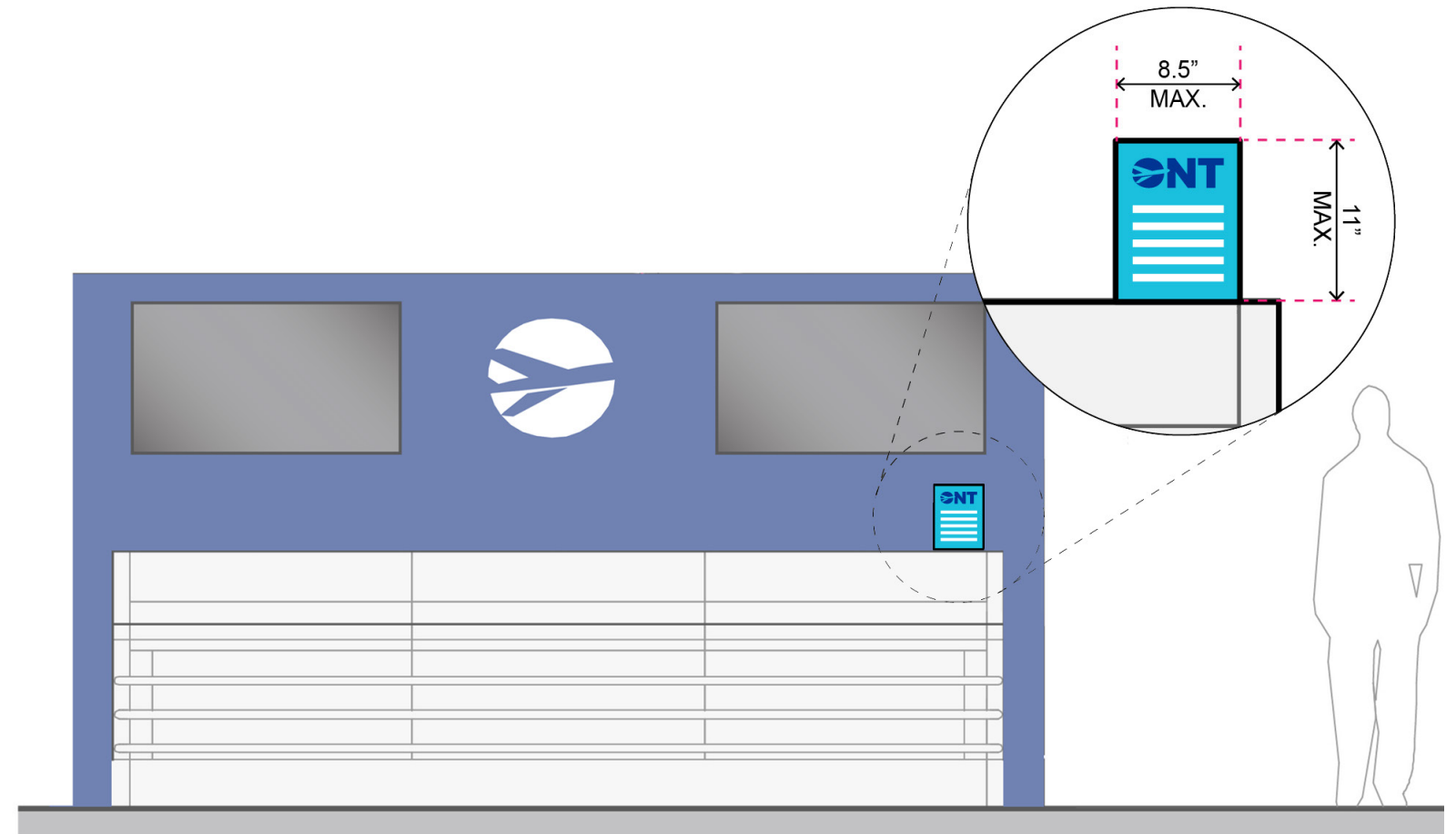

No Attachments to the Gate Counter, temporary or otherwise



Temporary Airline Initiatives are permissible with prior OIAA Approval See Temporary Signage Section

INTERIOR | BAGGAGE CLAIM

Description

No tenant signage is permitted in the baggage claim area.

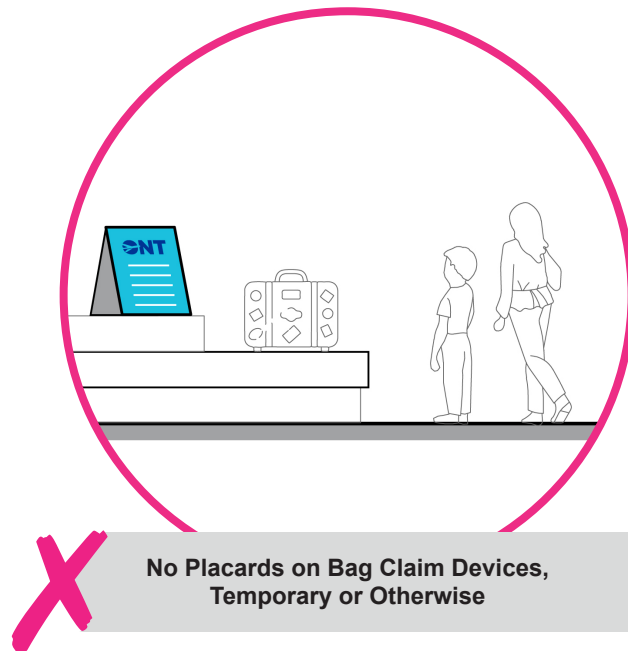

No Placards on Bag Claim Devices, Temporary or Otherwise

INTERIOR | BAGGAGE SERVICE OFFICE

Description

Tenant signature and informational signs are permitted in the baggage service office area. Signs within the office space will comply with the requirements and aesthetics of these Standards.

Location

A corporate signature sign may be adhered to the entrance door to the baggage service office.

A corporate signature sign may be within the baggage service office.

An office identification sign may be located in the window adjacent to the entrance door. Refer to 'office identification' section.

No signs will be attached to the exterior side of the window or adjacent surfaces.

Sign Size

The entrance door sign must fit within a single area not to exceed 2 feet wide by 2 feet high. The sign should be at least 3'-9" from the floor.

Image & Text Size

Copy will be limited to the tenant's corporate signature and brief descriptive text such as "Baggage Services," phone numbers, hours, etc.

The office interior sign will be limited to the corporate signature and brief descriptive text such as "Baggage Services."

Materials

The affixed entrance door sign will be either screened or vinyl graphics applied to the office interior side of the glass surface.

Quantity

One (1) entrance door sign per office.

One (1) corporate signature sign per office

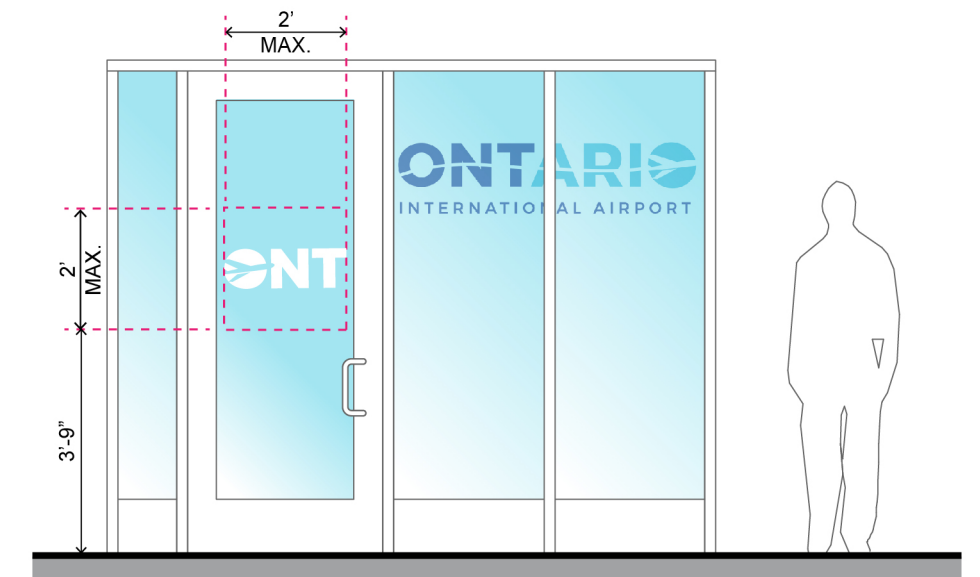

Temporary Signage Standards

Temporary signs may be necessary to safely and efficiently move passengers through the airport environment during disruptions such as construction, weather disruptions and maintenance issues. This can at times create very complex navigational challenges. The primary goal of these temporary signs will be to maintain the integrity of the wayfinding system.

It is important to design and fabricate the temporary signs using the same design criteria as the permanent signs with the exception of fabrication materials and mounting methods. Color, font, type size, nomenclature and message hierarchy should be maintained. This method allows for the signage system to maintain visual continuity, clean lines, and a sense of permanence thus instilling confidence in the passengers as they find their way through the airport.

Material

Interior

- Sintra type PVC board, styrene or other like rigid material with rounded corners
- Matte Vinyl applied directly to a painted smooth drywall finish

Exterior

- Sintra, aluminum, dibond or other like noncorrosive material with rounded corners
- Must be highly reflective in order to be read at night
- Must be able to withstand exposure to varying weather conditions

Font

- Open Sans

Directional Arrows

- Right arrows are placed to the right of the right justified text
- Left arrows are placed to the left of the left justified text
- Use of arrows should be consistent with permanent signage standards.
- Arrows should never point into text

Messaging

For consistent order and placement of messages it is important to establish primary messaging versus secondary messaging. Hierarchy includes prioritizing what information to list at a given decision point in the route.

Primary messages are:

- Ticketing/Check-in
- Baggage Claim
- Gates
- Ground Transportation

Secondary messages are:

- Concessions
- Elevators
- Information
- Parking
- Restrooms

Placement of arrows, symbols and the message will be consistent on all signs

Mounting

The recommended height from the bottom of the sign is 8 foot. In very low ceiling conditions, the minimum height per ADA standards is 6 foot and 8 inches.

The recommended method for mounting signs to temporary construction walls is screws or industrial strength double stick tape adhered to the back of the sign.

Tape shall not be visible on or near the exterior of the sign

In order to protect existing facility walls when mounting signs, the recommended method is application of blue painters' tape to the surface followed by application of industrial strength double stick tape.

Maintenance of Signs and Sign Holders

The tenant is responsible for maintaining all temporary signage for the duration of the project. Daily walks will be performed to inspect signs for the following:

- Clean
- Broken or cracked
- Graffiti
- Validate location appropriateness

Sign holders must be inspected and maintained on a daily basis. Sign inspections will consist of looking for and correcting the following:

- Damage
- Firm attachment to base
- Placement
- Cleanliness

Contractor Signage for Construction Projects

A project identification sign will be placed on the Construction Doors in public areas. The sign will have the following information:

- Construction area do not enter
- Personal Protective Equipment required
- Project name
- Contractor name
- Contractor phone number

Building Permit, OSHA, Contractor required signage must be posted on the interior of the temporary construction walls and doors, not visible to the public.

Interior Sign Locations

Because every terminal and associated curbside has a unique location, architecture, configuration and geometry, it is difficult to prepare generic signing plans and recommendations. Viewer circulation patterns and natural lines of vision are the basis for determining the location of all signs. OIAA must approve all Signage Locations.

Exterior Sign Locations

Signs may be mounted on the temporary construction fence, exterior walls, and freestanding posts. Careful consideration must be given to signs placed on fences along the side of roadways. Distractions to drivers cause a number of issues along the airport roadways. OIAA must approve all Signage Locations.

Sign Frequency and Avoidance of Sign Clutter

Directional signs should be located at decisions points and used as conformational signs if appropriate. Signing should be used primarily to direct traffic/pedestrians and identify items. Every direction must have a confirmation, so passengers know they have reached their destinations.

Sign Holders

Sign holders may be used in cases where construction walls are not suitable for wayfinding signs.

Stanchion Sign Stand

- Stanchion sign will be framed and firmly attached to the stanchion post top only.
- Maximum dimensions are 11 inches by 14 inches.
- A minimum 1-inch edge margin will be maintained around the copy.

A-frame

- Use of A-Frames needs to be approved by OIAA prior to installation.
- Exterior Only.
- Exterior grade painted board.
- Sign must be mounted to a substrate such as sintra type PVC board or styrene.
- Sign must be made with reflective vinyl background with reflective border using engineering grade or diamond grade vinyl.
- Minimum dimensions are 3 feet wide by 4 feet high.
- A-frame signs are subject to location placement review.

Promotional Signs

Contractor and their sub-contractors will not display company signs and logos in public areas.

Non-permitted Signs

The following signs and sign material are not permitted and may not be displayed on a temporary basis:

- Hand-written signs.
- Paper banners.
- Signs not approved by OIAA.
- No vertical lettered signs.

Sign Implementation Process

3-weeks prior to construction space shift(s) contractor will provide a barricade and sign plan to OIAA for review and a staff site walk. Signs will be manufactured prior to wall shifts in ensure wayfinding is in place as soon as the barricades have been installed.

Facilities Signage Standards

General Information

Colors & Fonts

Colors and fonts are limited to the ONT branding only.

Material

Typical sign construction must be painted aluminum or acrylic with applied vinyl, exceptions noted on each sign.

Illumination (internal or external) to be coordinated and field verified according to location.

Code Requirement

All signage to conform to the current sign codes.

Facilities Signs

Exterior

Building Mounted Signage

- Dimensional Letters

- Building Identification Signs

- Wall Mounted Signs

Freestanding Signage

- Pylon Signs

- Post & Panel Signs

Outline of Sign Types

Facilities Wayfinding Signage

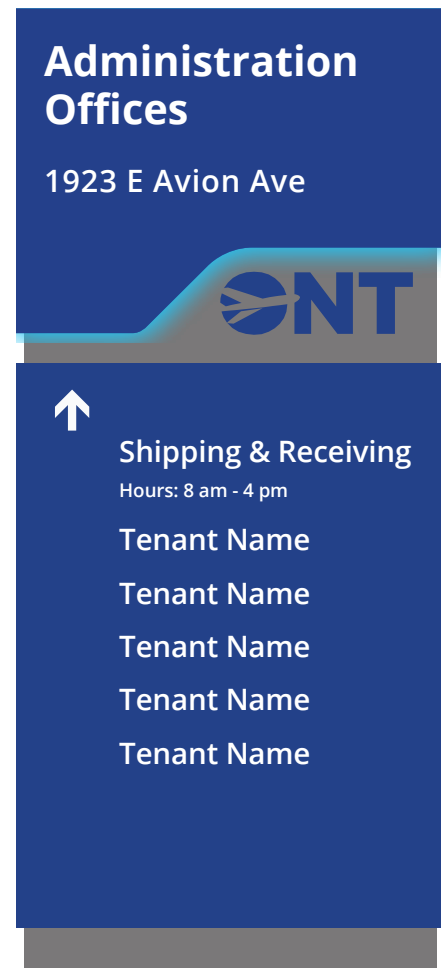

F-A1 FREESTANDING PYLON (VERTICAL)



F-B1 LARGE WALL MOUNTED SIGN



F-B2 SMALL WALL MOUNTED SIGN



F-B3 SMALL POST & PANEL

F-A1 FREESTANDING PYLON SIGN (VERTICAL)

Freestanding pylon signs near building entrances, to help drivers identify the building address and name, along with additional directions to other destinations at the airport campus.

Construction Notes:

1. Double-faced, 10" deep internally illuminated painted aluminum sign with push-through acrylic letters and concrete base. Colors indicated as noted.
2. Light blue LED accent lighting on the ascent.
3. ONT logo to be lit dark blue at night. Fabricator to coordinate color match and lighting method, approval by ONT is required.
4. Fabricated aluminum cabinet with internal structure as required.
5. Designer to field verify and determine best method of installation with minimal visual impact, sign to be anchored to concrete. Designer to provide structural engineering calculations as required and coordinate with general contractor for structural requirements.
6. Field verify existing conditions.

Alternate: Externally illuminated sign with painted aluminum structure with LED accent light. Copy and graphics to be reflective vinyl in colors as indicated.

Note: The scale of signage and graphics is subject to change in order to be compliant with ADA guidelines.

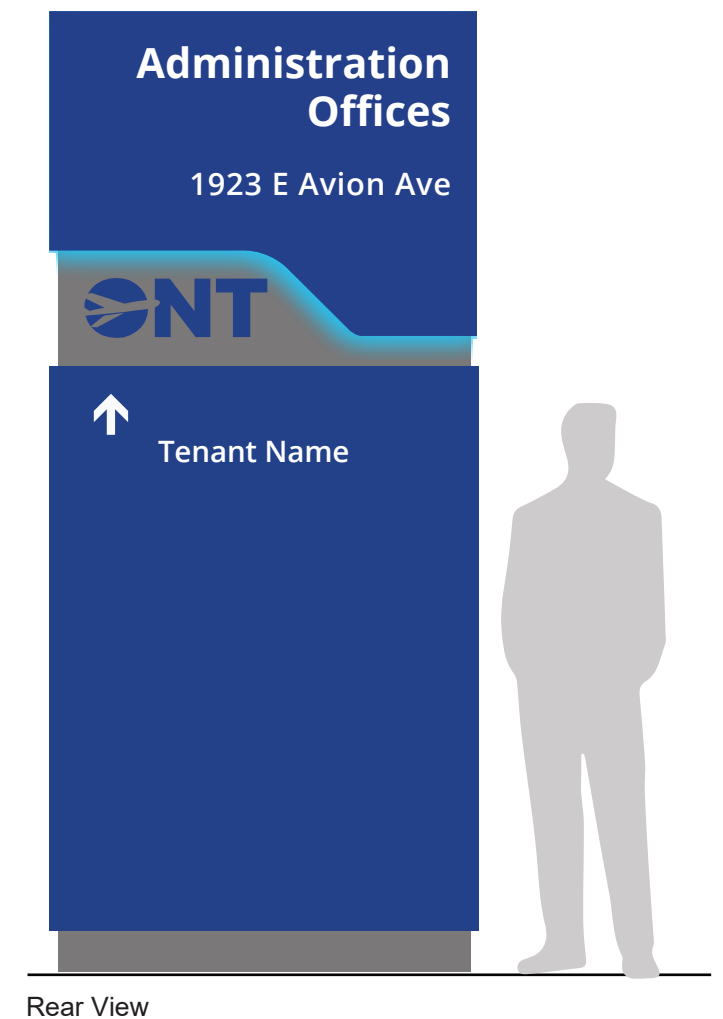
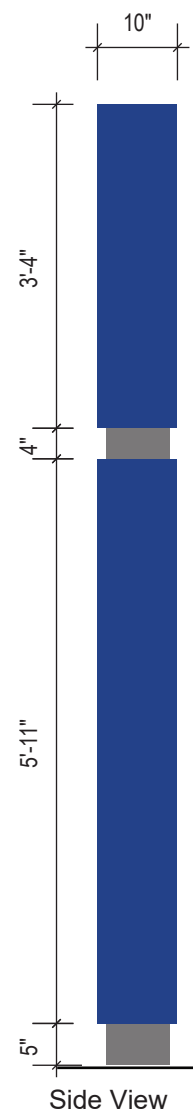
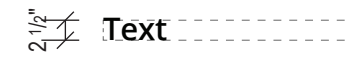

F-B1 LARGE WALL MOUNTED SIGN

Wall mounted sign panel, to help direct drivers to destinations around airport campus.

Construction Notes:

1. 1/8" single faced wall mounted painted aluminum sign with reflective vinyl copy and graphics .
2. Sign to be mounted on wall with concealed mechanical fasteners as required, fabricator to field verify each location prior to fabrication to determine wall conditions.
3. Designer to field verify and determine best method of installation with minimal visual impact. Designer to provide structural engineering calculations as required and coordinate with general contractor for structural requirements.
4. Field verify existing conditions.

Note: The scale of signage and graphics is subject to change in order to be compliant with ADA guidelines.

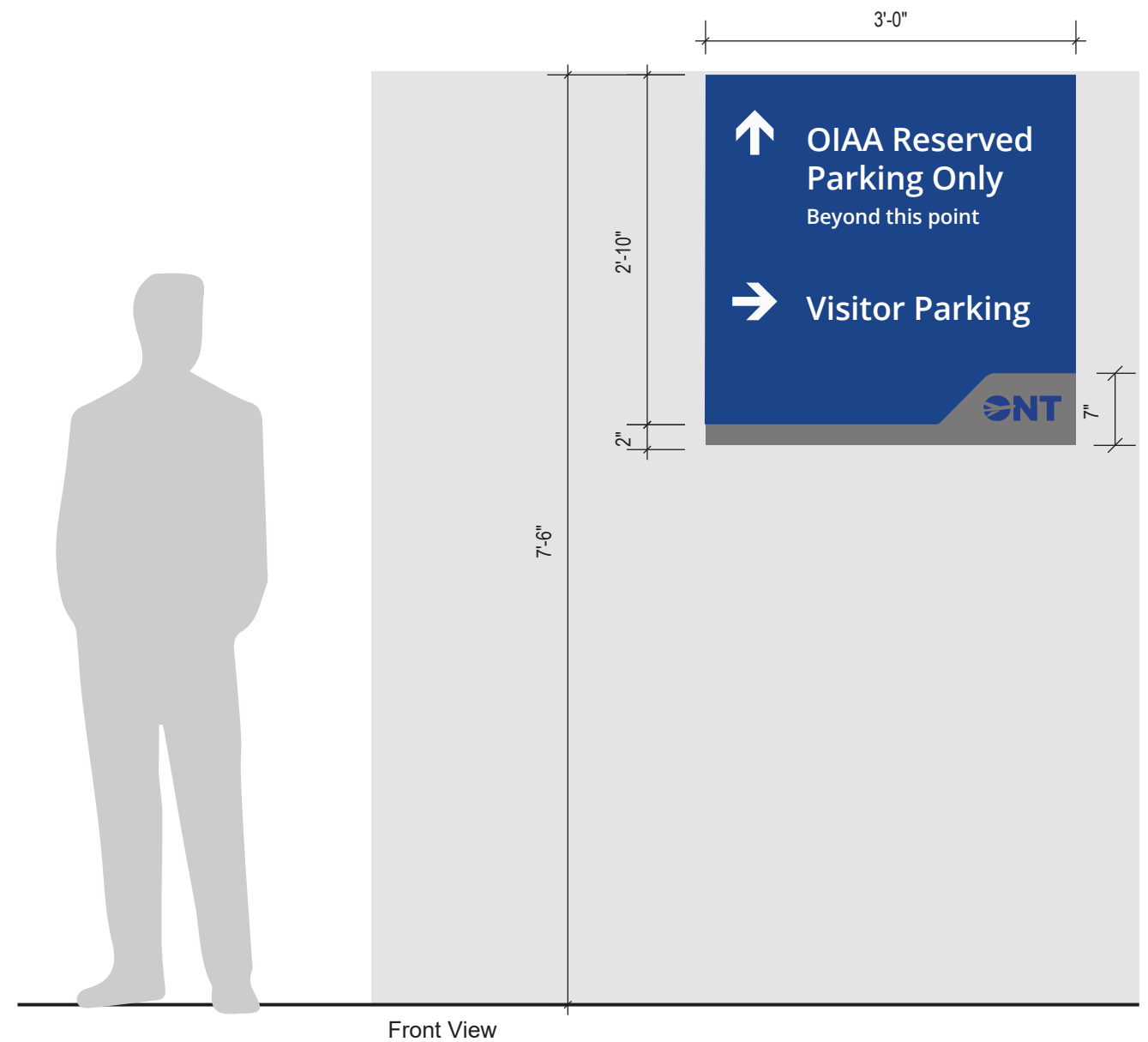
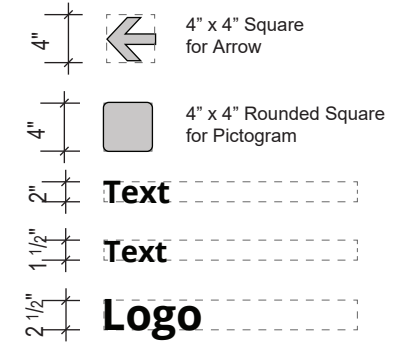

F-B2 SMALL WALL MOUNTED SIGN

Wall mounted sign panel, to help direct drivers to destinations around airport campus.

Construction Notes:

1. 1/8" single faced wall mounted painted aluminum sign with reflective vinyl copy and graphics .
2. Sign to be mounted on wall with concealed mechanical fasteners as required, fabricator to field verify each location prior to fabrication to determine wall conditions.
3. Designer to field verify and determine best method of installation with minimal visual impact. Designer to provide structural engineering calculations as required and coordinate with general contractor for structural requirements.
4. Field verify existing conditions.

Note: The scale of signage and graphics is subject to change in order to be compliant with ADA guidelines.

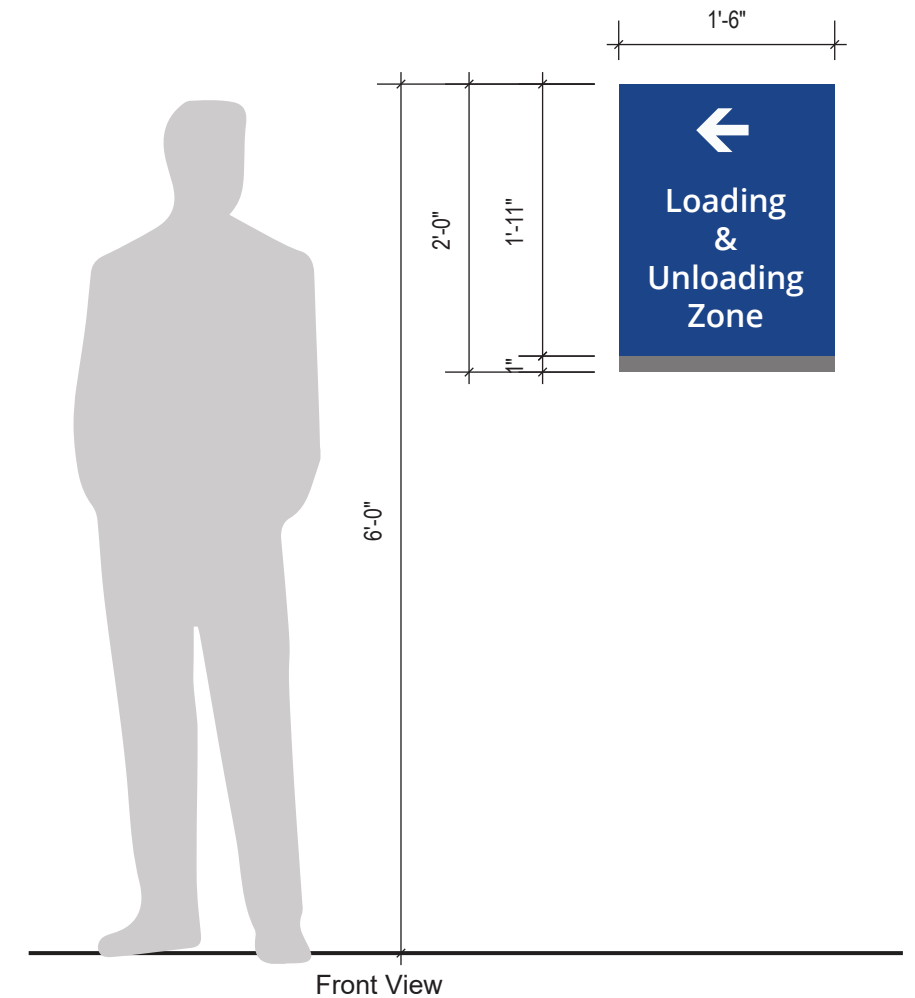
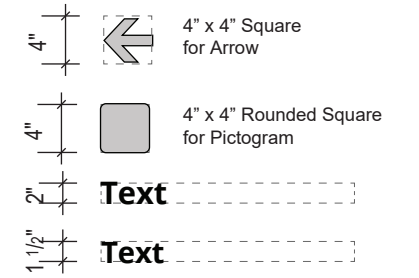

F-B3 SMALL POST & PANEL SIGN

Post mounted sign panels, to help direct drivers to destinations around airport campus.

Construction Notes:

1. Single-faced ground mounted post & panel sign.
2. 1/8" painted aluminum sign panel with applied reflective vinyl graphics in colors as indicated.
3. 3" deep Painted direct burial aluminum posts, in colors as indicated.
4. Designer to field verify and determine best method of installation with minimal visual impact. Designer to provide structural engineering calculations as required and coordinate with general contractor for structural requirements.
5. Field verify existing conditions.

Note: The scale of signage and graphics is subject to change in order to be compliant with ADA guidelines.

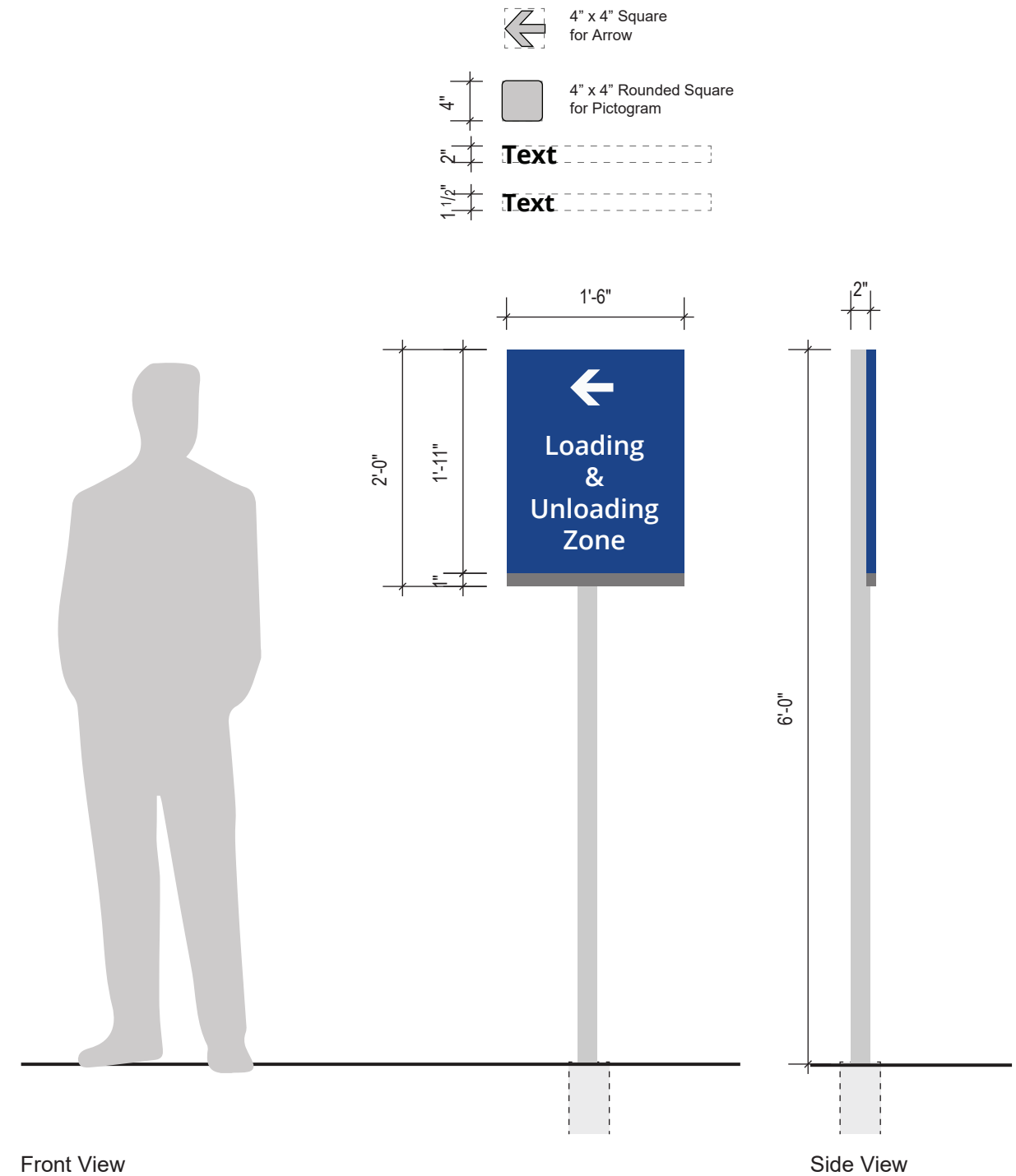

Campus Signage Standards

General Information

The Airport's approach to signage is that it should be used to support wayfinding, not advertising. At no time should a developer's design consultant or subcontractor display signage (free-standing signs, trailers, etc.) for advertising purposes. Signage is controlled and all installations within the Airport must be reviewed and approved by OIAA.

Basic standards and guidelines have been established and additional standards or signage programs shall be established, and/or amended from time to time, for specific development districts as the Airport seems necessary.

INTENT OF CAMPUS SIGNAGE AT ONT

Tenants are encouraged to be expressive and imaginative when designing signs to aid the public in using airport facilities efficiently and with a minimum of confusion. In short, the acceptable criteria for each sign is that it address the immediate needs of airport campus users.

The intent of signage is to provide adequate direction so that the sign systems will:

1. Provide an effective source of needed information
2. Maintain quality of design that is compatible with the aesthetics of ONT. Great importance is placed on good taste, originality, and fine materials.
3. Be attractive and use colors and materials that are compatible with the surrounding airport campus.

PURPOSE OF THE CAMPUS SIGNAGE STANDARDS

The Campus Signage Standards establish conformance criteria for all tenant signage proposed for existing, new and remodeled facilities under OIAA jurisdiction at the airport and its environs. These Standards are meant to provide the maximum limitations for tenant signing of any kind allowed in these areas.

The Standards will be periodically reviewed by OIAA and are subject to revision at its discretion.

Campus Signs

Temporary Signage

- Temporary Situational Signage
- Lease Signs

Building Mounted Signage

- Occupant Identification Signs
- Building Address Signs
- Window Signs

Freestanding Signage

- Monument Signs - Corporate, Office, Industrial & Warehouse
- Monument Signs - Retail, Hospitality & Mixed-Use

SIGN SUBMITTAL & OIAA APPROVAL

All signs must be approved by OIAA prior to installation. New, changed or renovated signs must conform to these Standards.

If any existing sign exceeds the limitation stated in the Standards, but has been previously approved by OIAA, that sign will be replaced to conform to the current Standards in a reasonable amount of time as determined by OIAA.

Temporary signs must be submitted for review and approval. Refer to the “Temporary Signage Standards” section for details.

REVIEW & COMPLIANCE

All signs are subject to periodic reviews by OIAA to ensure compliance to these Standards. Signs will be inspected for content compliance and to ensure that the minimum sign fabrication quality is maintained. This will include sign structure, paint or finish, and applied materials, i.e. plastics, vinyl lettering, fasteners, etc. Internally illuminated signs will be checked for proper working order before final acceptance.

In the event that an existing sign is found to be out of compliance with these Standards, OIAA will notify the tenant with a written notice. The tenant is required to remove and refurbish the sign up to or exceeding the quality of the original permitted condition according to the guidelines described in the Regulation Enforcement section of these Standards. If the tenant’s sign does not satisfy permitted condition standards at the end of the prescribed adjustment period, OIAA reserves the right to directly resolve the matter by removing it and billing all costs to the tenant.

REGULATION ENFORCEMENT

All tenants must obtain the written approval of OIAA for each sign. Any sign installed without the written approval of OIAA will be removed. Upon notification of the demand to remove a non-conforming or non-permitted sign, the tenant must remove sign within 48 hours.

If the tenant does not remove the sign in the allotted time, OIAA reserves the right to directly resolve the matter by removing it and billing all costs to the tenant.

Previously approved existing signs that do not conform to these Standards will be replaced to conform to the current standards in a reasonable amount of time as determined by OIAA.

Tenants may change or alter an existing permanent sign only with the written approval of OIAA. If leaseholds are modified or improved, any existing signage within the improvement area must conform to these Standards. Such existing signage may require a full replacement.

Standards & Regulations

RESPONSIBILITY & INTENT

1. Signage in public areas is the responsibility of OIAA. Signage within leased areas is the responsibility of the tenant.
2. All signs will be of an informative nature designed to meet the immediate needs of the public. Signs of an advertising or promotional nature are not permitted unless an executed Advertising Agreement is in place with OIAA.
3. Signs not covered in these standards are to be approved by OIAA.

APPLICABLE CODE REQUIREMENTS

The tenant will have sole responsibility for compliance with all applicable federal, state, and local building codes, ordinances and other jurisdictional regulations.

Access for the disabled will be provided, as required by the City of Ontario, Title 24 of the California Administrative Code, the Americans with Disabilities Act of 1990, and any and all other applicable statutes, rules, regulations, codes and ordinances.

The tenant will be responsible for submitting the construction documents to the City of Ontario Department of Building and Safety and other jurisdictional agencies for plan check review and approval and for securing all the necessary building permits.

SIGN PLACEMENT

1. No signs will be permitted on doors or windows except those required to meet safety or regulatory standards.
2. No signs will be permitted on the roof of any building. This regulation also applies to any structure atop a building.
3. All signs are to be surfaced-mounted within the architectural elevation of the demised premises unless otherwise approved by OIAA.

ILLUMINATION

1. Only individually mounted, internally illuminated letters, pin mounted and back washed letters are acceptable. No cabinet signs are permitted.
2. No exposed neon, animated, or flashing signs are permitted. Internally illuminated signs will be kept to a minimum using translucent acrylic diffusion to control the brightness. Illuminated signs will be allowed only in specific circumstances mentioned in the text of these standards. All illuminated signs will meet all code requirements and bear the label of the Underwriters Laboratories, Inc.

ACCEPTABLE MATERIALS

1. Porcelain enamel on aluminum or aluminized sheet steel
2. Anodized aluminum
3. Paint on aluminum—paint must be linear polyurethane for all under coats and top coats
4. Acrylic and fiberglass with satin finish only
5. Other materials may be reviewed and considered by OIAA

The materials listed above are not acceptable for illuminated signs.

UNACCEPTABLE MATERIALS

1. Rustic, unfinished, or distressed wood
2. Rustic stone or brick
3. Plastic
4. Any oxidizing metal
5. Clay
6. Simulated or faux finish

FABRICATION & INSTALLATION

The fabrication and installation of all signs will be of a permanent nature using established methods and quality materials and hardware. Only high-quality workmanship performed by qualified tradespeople will be permitted.

Attachment hardware and connections of all signs must be non-corrosive and engineered to ensure public safety. No exposed can, raceways, or crossovers will be permitted. Fabrication and installation must comply with all applicable City of Ontario Building and Sign Codes.

MAINTENANCE

Tenants must maintain each approved sign in a neat, clean, orderly and safe manner. Failure to maintain an approved sign will result in revocation of approval and subsequent removal.

Temporary Signage Standards

TEMPORARY SITUATIONAL SIGNAGE

Temporary signs may be necessary during disruptions such as construction and maintenance issues. This can at times create very complex navigational challenges. The primary goal of these temporary signs will be to maintain the integrity of the wayfinding system.

It is important to design and fabricate the temporary signs using the same design criteria as the permanent signs with the exception of fabrication materials and mounting methods. Color, font, type size, nomenclature and message hierarchy should be maintained. This method allows for the signage system to maintain visual continuity, clean lines, and a sense of permanence thus instilling confidence in the passengers as they find their way through the airport campus.

Material

Interior

- Sintra type PVC board, styrene or other like rigid material with rounded corners
- Matte Vinyl applied directly to a painted smooth drywall finish

Exterior

- Sintra, aluminum, dibond or other like noncorrosive material with rounded corners
- Must be highly reflective in order to be read at night
- Must be able to withstand exposure to varying weather conditions

Mounting

The recommended method for mounting signs to temporary construction walls is screws or industrial strength double stick tape adhered to the back of the sign.

Tape shall not be visible on or near the exterior of the sign.

To protect existing facility walls, the recommended method for mounting signs is application of blue painters' tape to the surface followed by application of industrial strength double stick tape.

Sign Holders

Sign holders may be used in cases where construction walls are not suitable for wayfinding signs.

Stanchion Sign Stand

- Stanchion sign will be framed and firmly attached to the stanchion post top only.
- Dimensions are 11 inches by 14 inches.
- A minimum 1-inch margin will be maintained around the copy.

A-frame

- Use of A-Frames needs to be approved by OIAA prior to installation.
- Exterior Only.
- Exterior grade painted board
- Sign must be mounted to a substrate such as sintra type PVC board or styrene
- Sign must be made with reflective vinyl background with reflective border using engineering grade or diamond grade vinyl
- Minimum dimensions are 3 feet wide by 4 feet high
- A-frame signs are subject to location placement review

Maintenance of Signs and Sign Holders

The tenant is responsible for maintaining all temporary signage for the duration of the project. Daily walks will be performed to inspect signs for the following:

- Clean
- Broken or cracked
- Graffiti
- Validate location appropriateness

Sign holders must be inspected and maintained on a daily basis. Sign inspections will consist of looking for and correcting the following:

- Damage
- Firm attachment to base
- Placement
- Cleanliness

Contractor Signage for Construction Projects

A project identification sign will be placed on the Construction Doors in public areas. The sign will have the following information:

- Construction area do not enter
- Personal Protective Equipment required
- Project name
- Contractor name
- Contractor phone number

Building Permit, OSHA, Contractor required signage must be posted on the interior of the temporary construction walls and doors, not visible to the public.

Promotional Signs

Contractor and their sub-contractors will not display company signs and logos in public areas.

Exterior Sign Size and Locations

Signs may be mounted on the temporary construction fence, exterior walls, and freestanding posts. Careful consideration must be given to signs placed on fences along the side of roadways. Distractions to drivers cause a number of issues along the airport roadways. OIAA must approve all signage locations.

Sign Frequency and Avoidance of Sign Clutter

Directional signs should be located at decisions points and used as conformational signs if appropriate. Signing should be used primarily to direct traffic/pedestrians and identify items. Every direction must have a confirmation, so traffic/pedestrians know they have reached their destinations.

Non-permitted Signs

The following signs and sign material are not permitted and may not be displayed on a temporary basis:

- Hand-written signs
- Paper banners
- Signs not approved by OIAA
- No vertical lettered signs

Sign Implementation Process

3-weeks prior to construction space shift(s) contractor will provide a barricade and sign plan to OIAA for review and a staff site walk. Signs will be manufactured prior to wall shifts in ensure wayfinding is in place as soon as the barricades have been installed.

LEASE SIGNS

Lease signs are available for temporary use but must be approved by both OIAA and Revenue Management Division.

A standard sign design has been developed as a "For Lease" sign to be used to advertise available lease space. Layout of sign copy shall be submitted to OIAA for review and approval. Use of this sign is not for advertising the property management company, developers, or design consultants and contractors, and must be removed within 5 days of lease of the last unit. The surrounding land should be properly kept and maintained in a neat and orderly presence until time of sign removal. The sign must not obstruct or block the view from any driveway. All structural support must be removed in addition to the sign, and any disturbed landscaping must be restored.

As space becomes available during the term of the lease agreement, the Tenant may install a new "For Lease" sign no more than 180 days prior to the end of the sublease term. The new sign must meet then applicable design criteria as may be in place at that time and submitted to OIAA for approval.

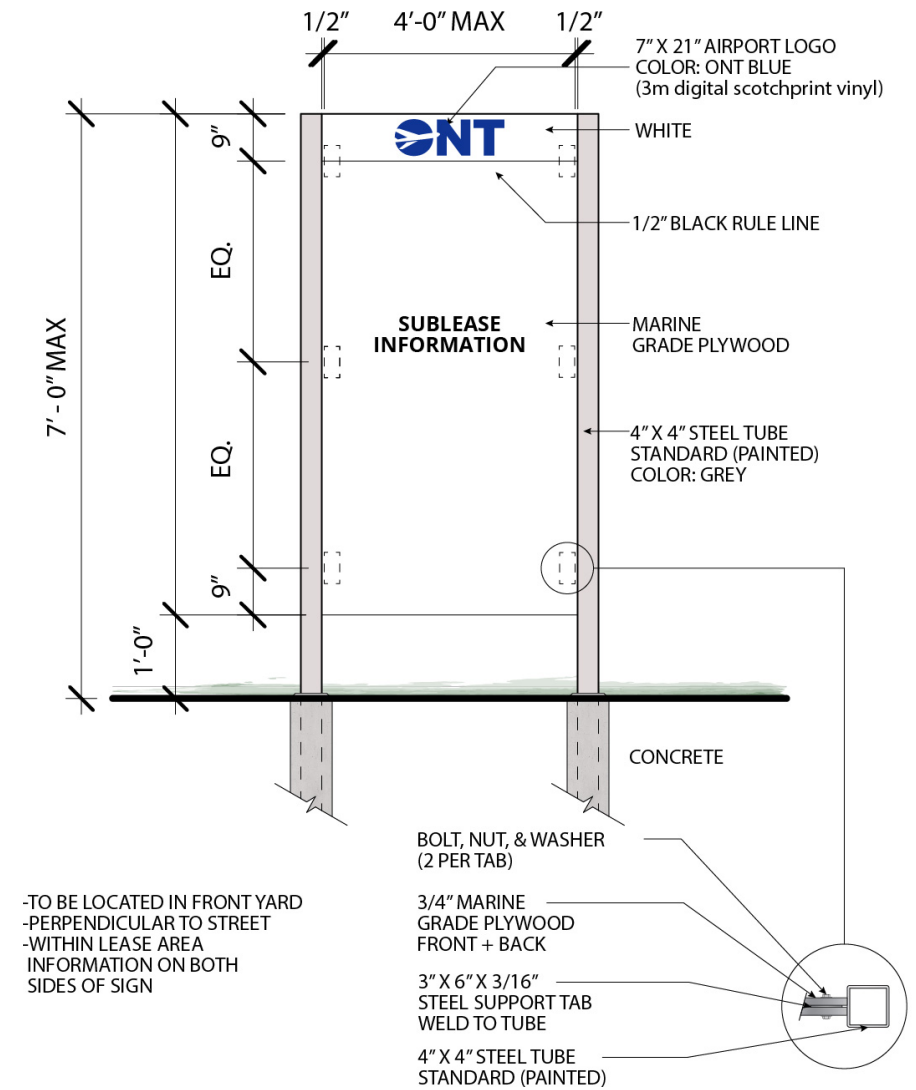

Building Mounted Signage

Signage attached on the face of the buildings must be architecturally compatible with character of the building and surrounding development. These signs are allowed to support wayfinding; therefore, signs must be oriented to achieve maximum visibility from the public roadway and should be placed in a manner that compliments the architectural elements.

In general, signage shall be designed to complement the building it serves, as well as support the unifying character of the development.

- All sign types shall utilize an established material and color palette.
- Tenants of similar functions within the development shall sign consistently.
- All signs shall be designed as an integral part of the store front design, with letter size and location appropriately scaled and proportioned to the overall store front design.

All signs must provide a minimum of nine (9) feet above ground of clearance if located above a sidewalk, park or other pedestrian area.

OCCUPANT IDENTIFICATION SIGNS

Occupant identification signage is meant to locate and identify the primary building tenant or a storefront tenant.

- All signage that includes trademarks or other branded logos shall be allowed, but they are still required to conform to regulations outlined below.
- Signs shall consist of individual channel letters placed flat against the exterior wall or parapet of a building and having an overall depth of no more than 12 inches.
- Branding shall be incorporated within sculptured cabinets; however, the cabinet sign shall not exceed 25 percent of the total sign area of each sign.
- One Occupant Identification Sign shall be permitted for each tenant having an exterior public entrance.
- The maximum span of the tenant's sign shall not exceed 75% of the store frontage width or 150 square feet, whichever is more restrictive.
- For retail spaces, the copy height of each tenant's sign shall not exceed 24 inches in height.

- The information on the sign shall consist of the name and/or logo of the tenant in a font style of their choice.
- Mounting hardware shall be non-corrosive and concealed from public view.
- Installation hardware and mountings should limit potential for nesting of birds.
- Signs shall not be placed to obstruct any portion of a window or cover architectural elements, such as cornices, transom windows, vertical piers and columns, and similar elements.

BUILDING ADDRESS SIGNS

The building's address numbers shall be located at the main entry of the building where they are visible from the road in minimum 24-inch high numbers. Additional address numbers may be installed on the building facing the roadway. Road names can be included in 12-inch high letters. It is at the discretion of local authorities to require additional signs be installed on the building for wayfinding purposes. Color of address numbers and letters must be in high contrast with building color.



WINDOW SIGNS

Window signs are meant to allow for additional tenant signage but shall preserve a level of transparency.

- Decal application graphics shall be allowed on glass areas of store fronts, offices, and leasing areas.
- Applications shall be vinyl die-cuts applied directly to the glass.
- Signs shall consist of individual letters having a letter height of no more than 12 inches.
- Branding may be incorporated; however, the branding shall not exceed 25 percent of the total sign area.
- If the application is on a window, the total length of sign shall not exceed 75% of the total window length on center and be no more than 50% of the window height on center.
- If the application is on a window within a door, the signage shall exist within a 2' x 2' square area on center with the window.
- No temporary advertising placards, banners, pennants, trademarks or other descriptive material may be placed on the inside of the glass.

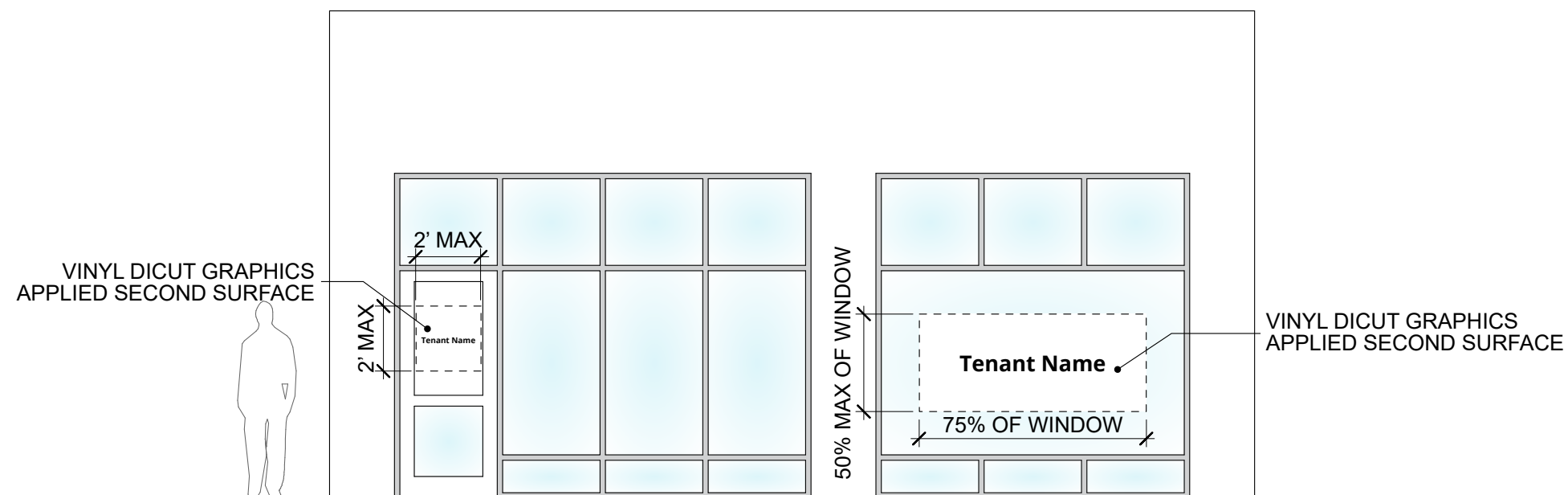

Free-Standing Signage

All tenant identification, directional, or informational signage not attached to the building shall comply with standards established.

MONUMENT SIGNS - CORPORATE, OFFICE, INDUSTRIAL & WAREHOUSE

The Airport has established a standard building marker for use throughout the Airport at appropriate facilities such as, but not necessarily limited to: corporate offices, flex-offices, and warehouses to identify the tenant(s) of the facility.

The sign is two-sided, externally illuminated with ground mounted light fixtures, to achieve illumination of the entire structure.

The design, size, shape and materials are standardized. The occupant(s) name and/or logo should be centered within the allowable tenant field. The minimum letter height shall be 8 inches.

The building address numbers and Airport logo shall be located on the monument sign. Address numbers and ONT Logo shall be a minimum of 6 inches in height and shall be clearly visible from the adjacent public street. Refer to OIAA Marketing for the appropriate Airport Branding and Logo and its usage on the sign.

The sign structure shall be surrounded by an 18-inch minimum bed of gravel base.

No monument sign shall be located within a public right-of-way and must be wholly located behind the right-of-way line (street property line) for its full height. Furthermore, such signs shall be located a minimum of 10' behind the adjacent curb face (public and private streets).

MONUMENT SIGNS - RETAIL HOSPITALITY & MIXED-USE

Signs for these land uses have special branding and public awareness needs but are expected to establish aesthetic controls. A signage system will be required that illustrates a consistency among the proposed individual sign structures (entry features, building markers, tenant storefront signs) and the architectural character of the development.

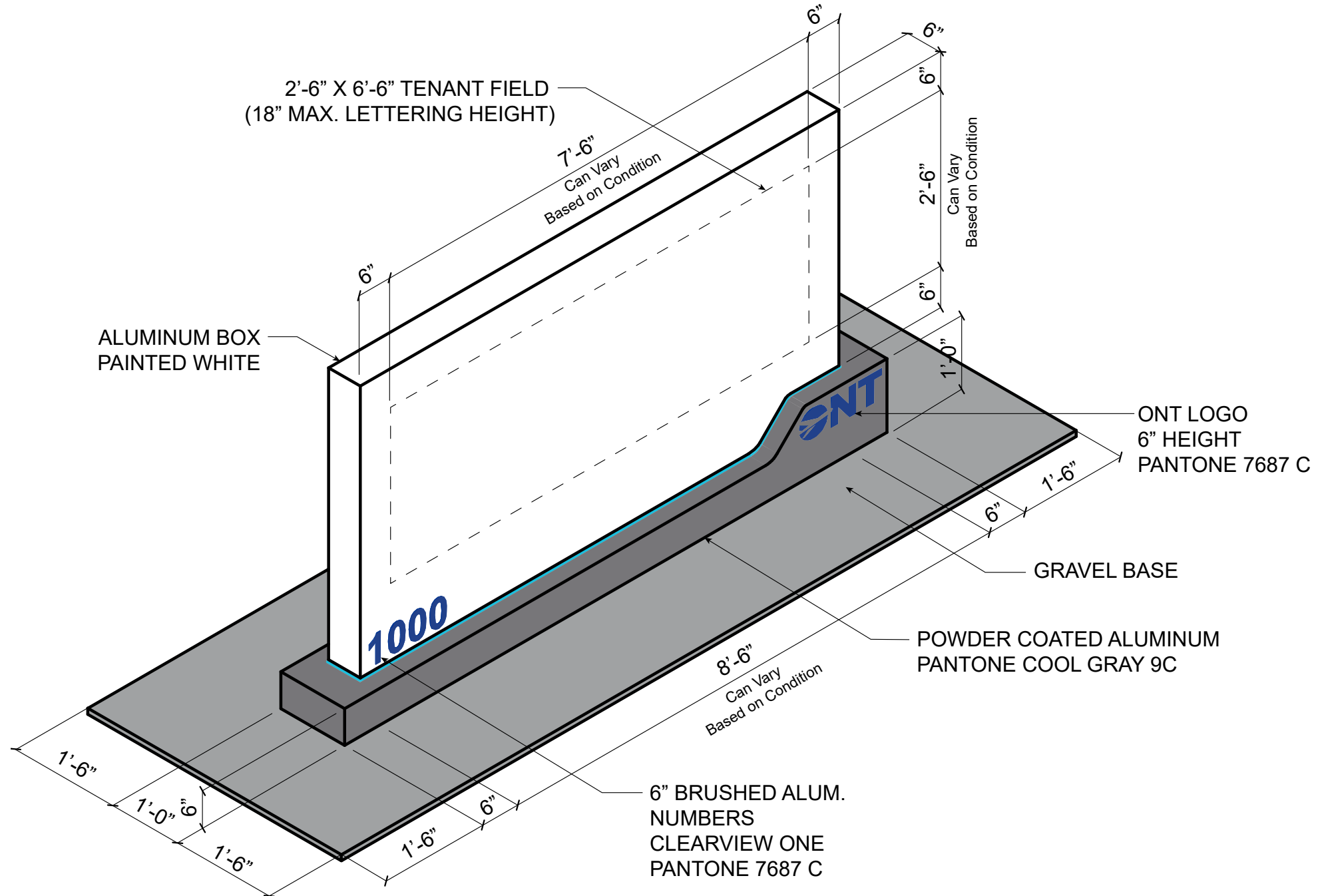

Appendix

Signage Location Plans and Message Schedule

TERMINAL 2 - LANDSIDE - DEPARTURES / ARRIVALS CURB

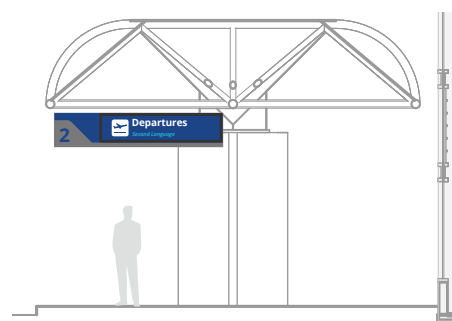
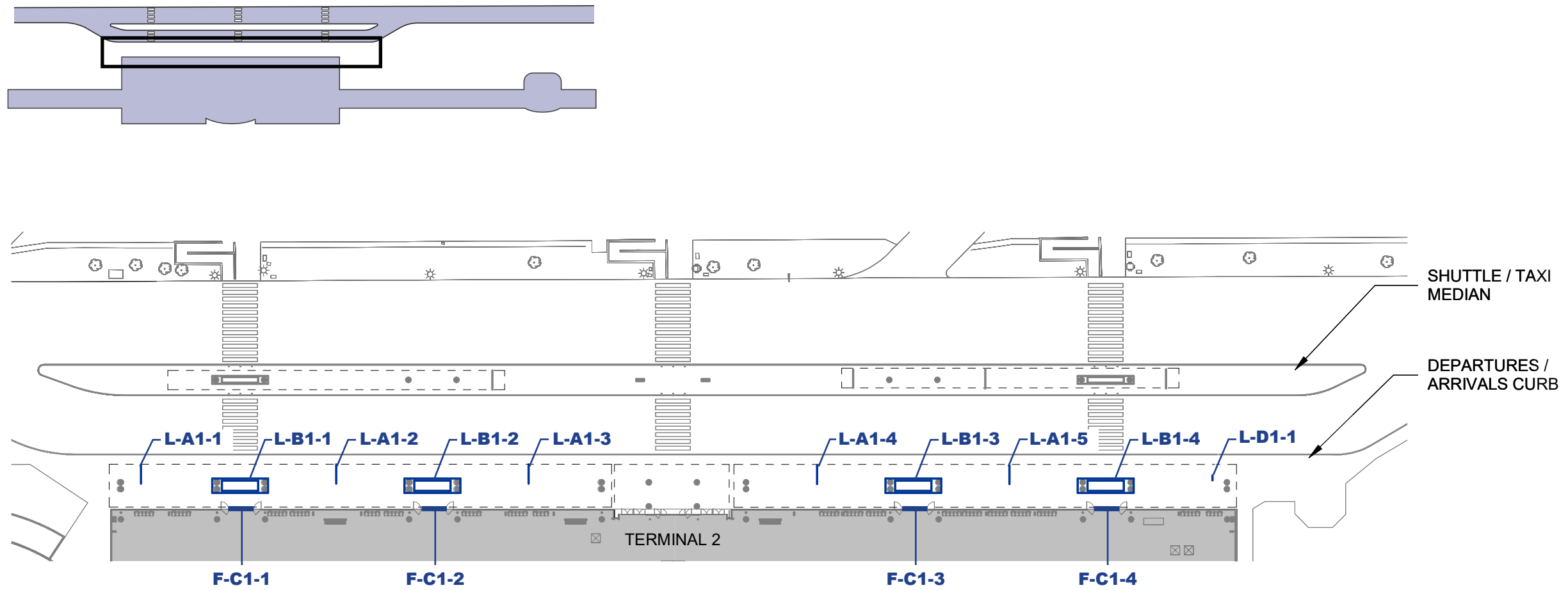

L-A1

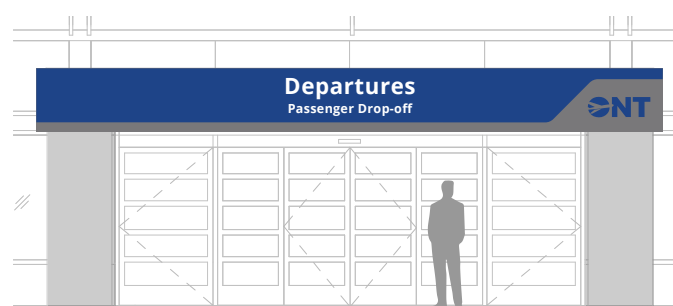

L-B1

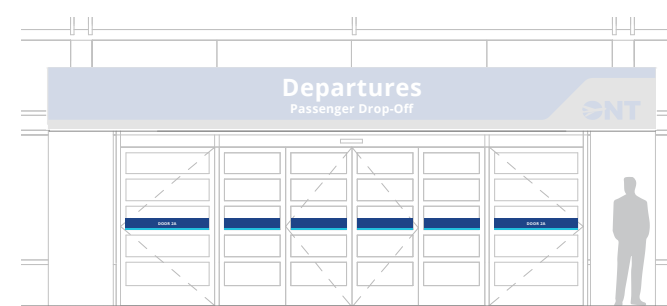

L-C1

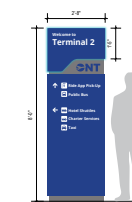

L-D1

TERMINAL 2 - LANDSIDE - SHUTTLE / TAXI MEDIAN

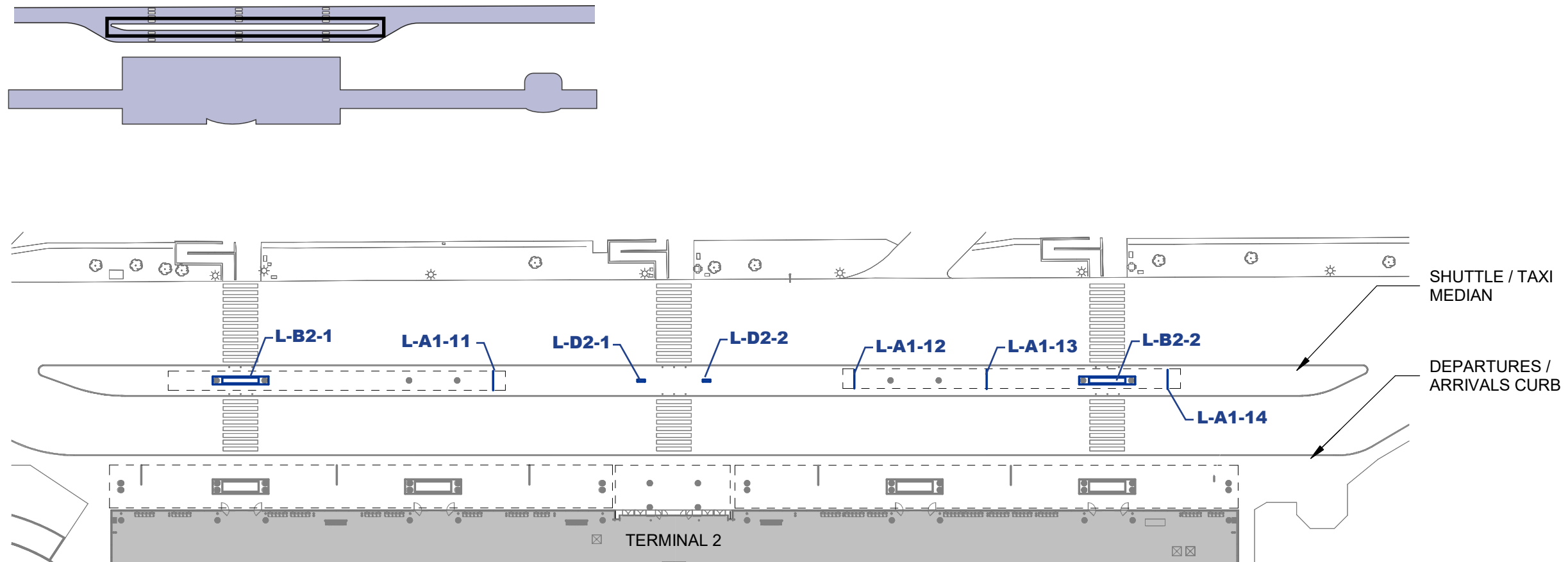

L-A1

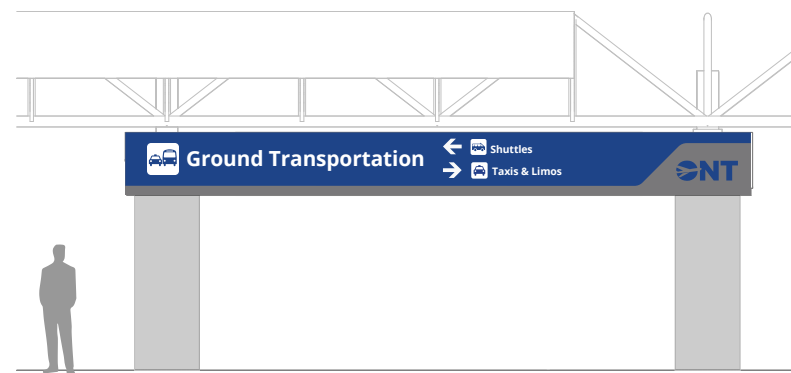

L-B2



L-D2

TERMINAL 2 - LANDSIDE

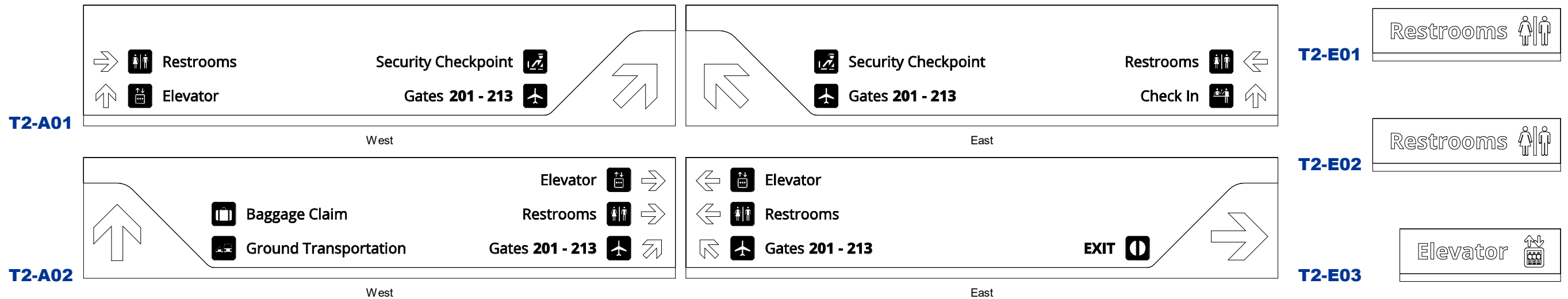
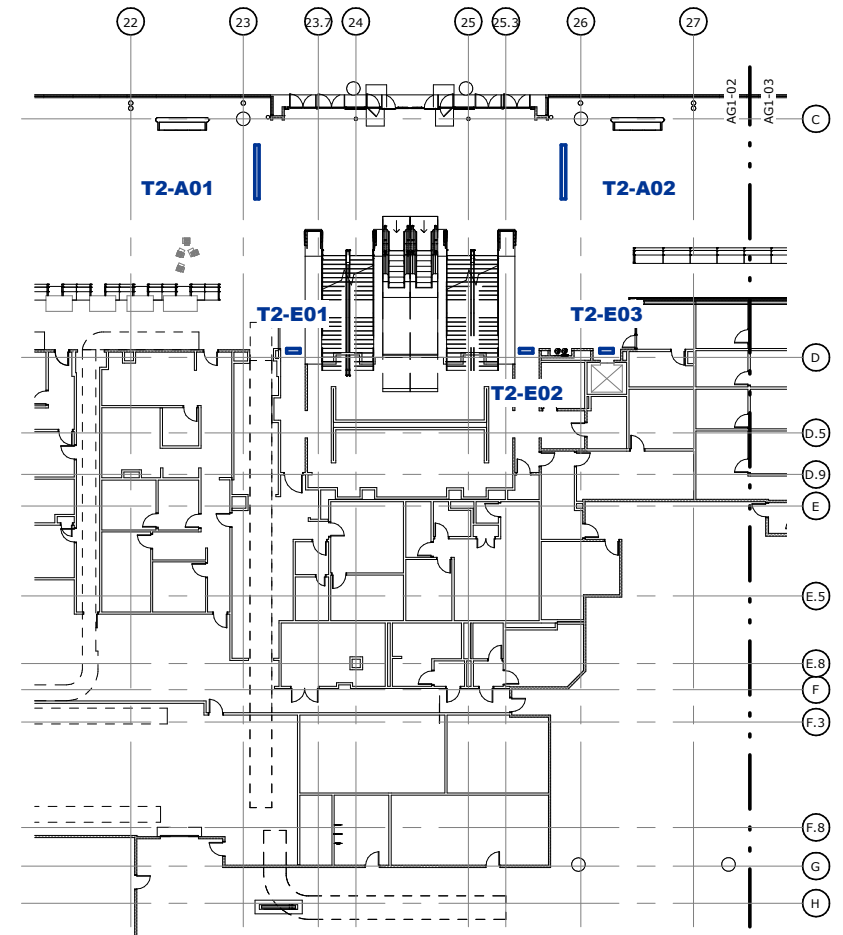
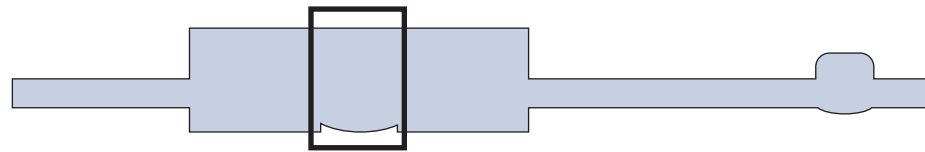

TERMINAL 2 - LANDSIDE

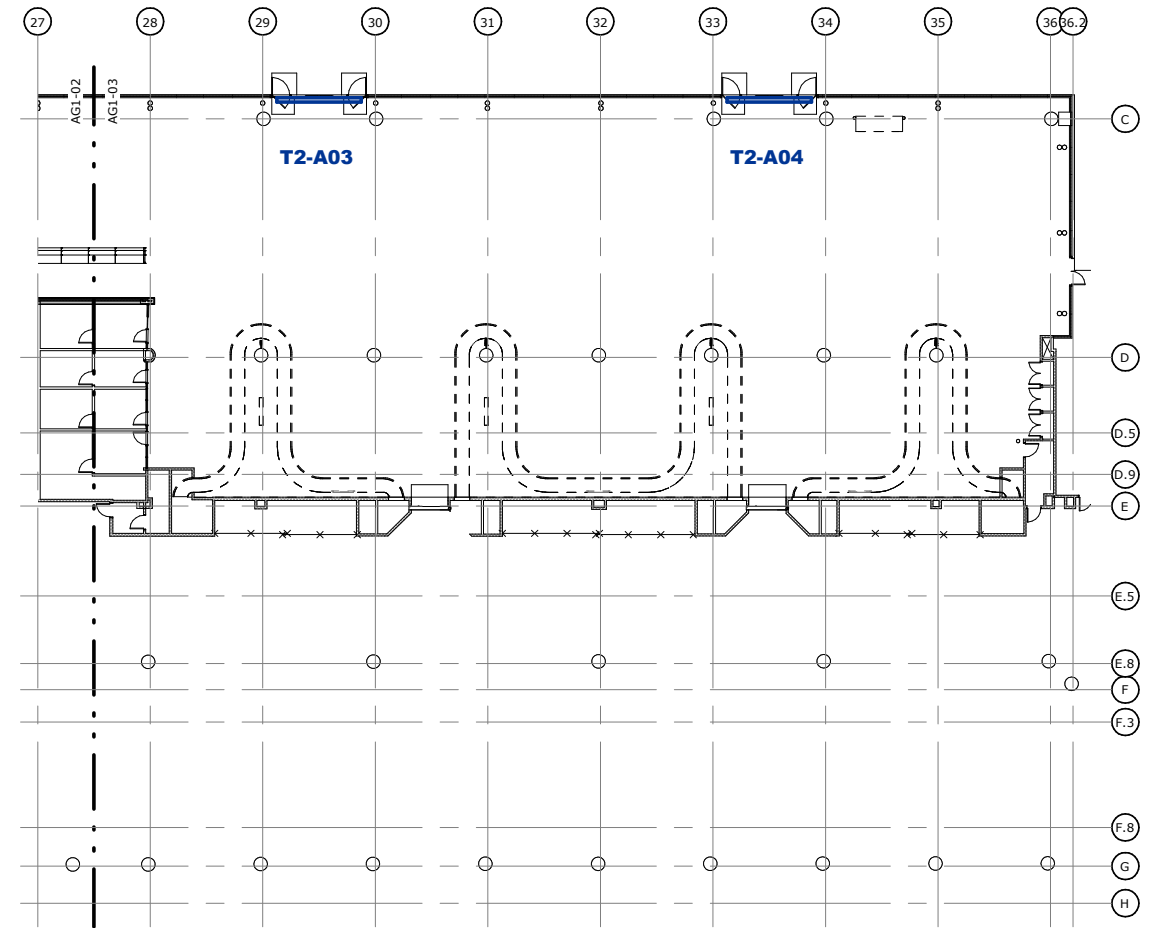
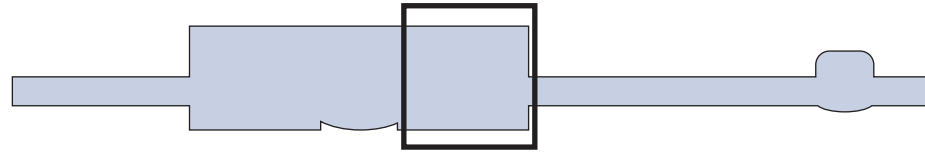

T2-A03

Not Applicable

North

T2-A04

Not Applicable

North



TERMINAL 2 - WEST

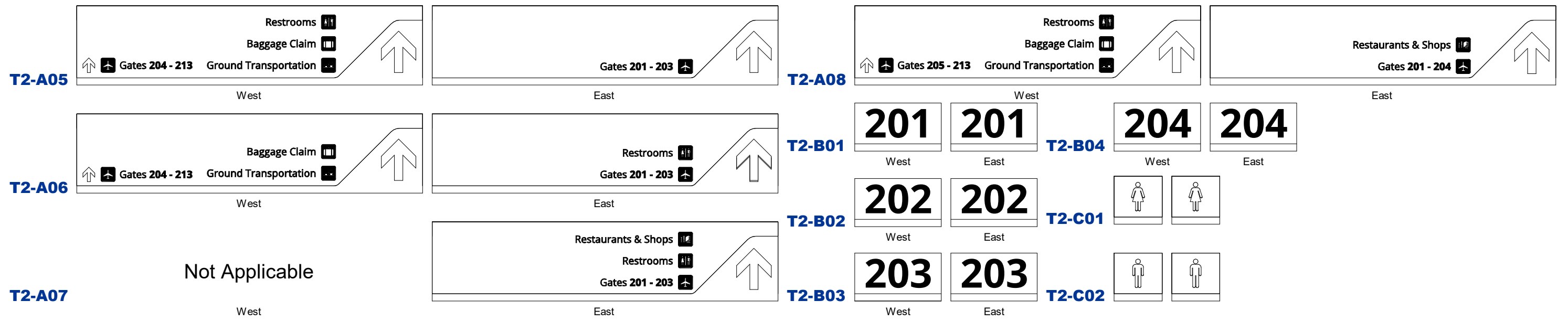
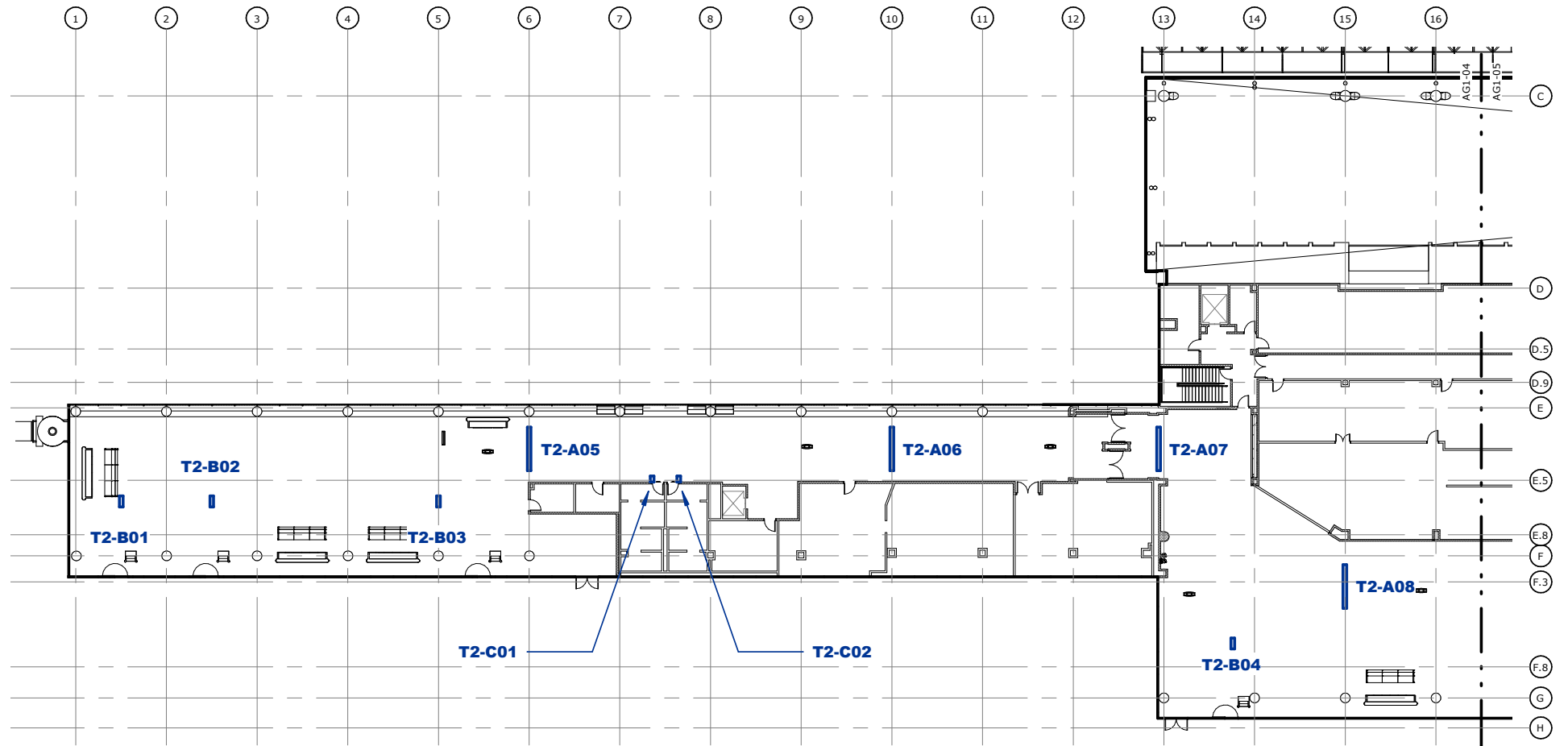
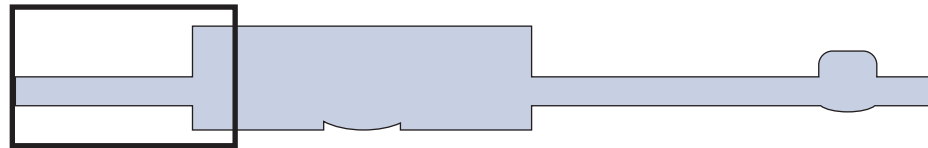

TERMINAL 2 - WEST AND CENTER

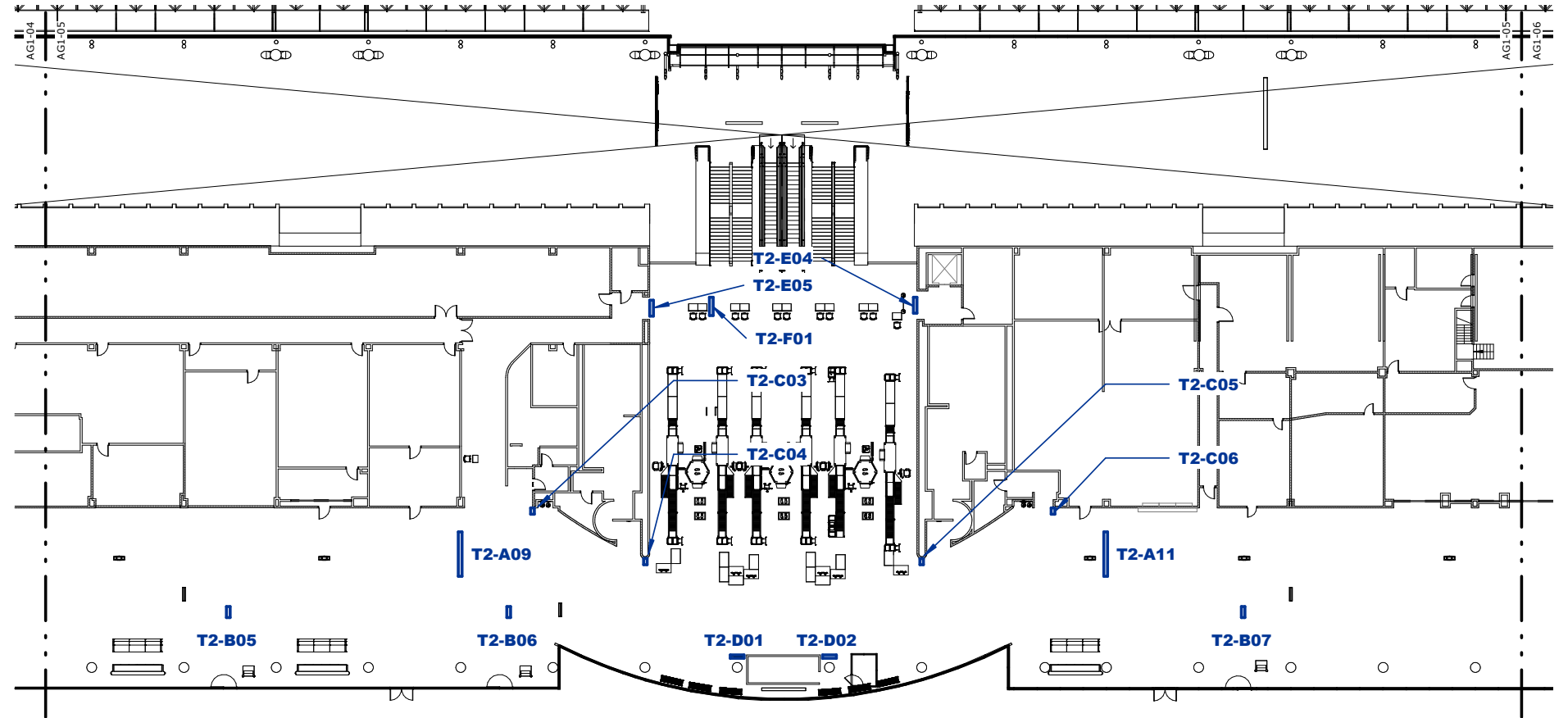
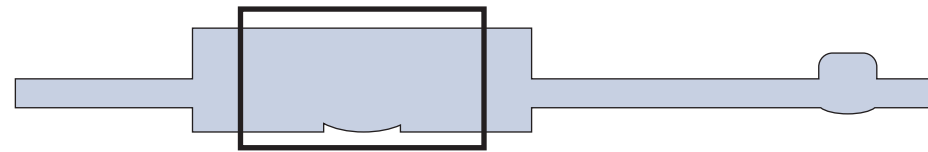

<p>T2-A09</p>	<p style="text-align: center;">West</p>	<p style="text-align: center;">East</p>	<p>T2-B05</p>	<p>205</p> <p>West</p>	<p>205</p> <p>East</p>	<p>T2-C04</p>		<p style="text-align: center;">T2-D01 & T2-D02</p>
<p>T2-A11</p>	<p style="text-align: center;">West</p>	<p style="text-align: center;">East</p>	<p>T2-B06</p>	<p>206</p> <p>West</p>	<p>206</p> <p>East</p>	<p>T2-C05</p>		
<p>T2-E04</p>			<p>T2-F01</p>	<p>207</p> <p>West</p>	<p>207</p> <p>East</p>	<p>T2-C06</p>		

TERMINAL 2 - EAST CONNECTOR

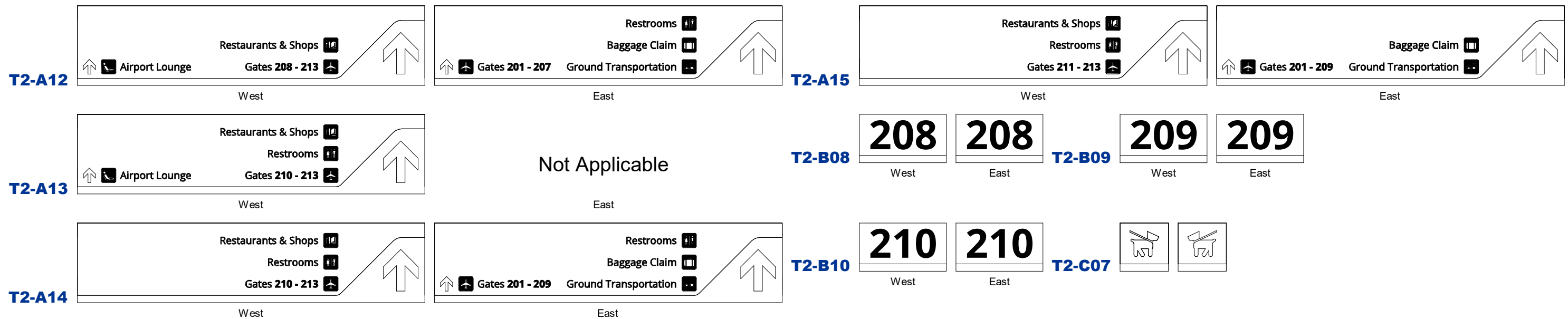
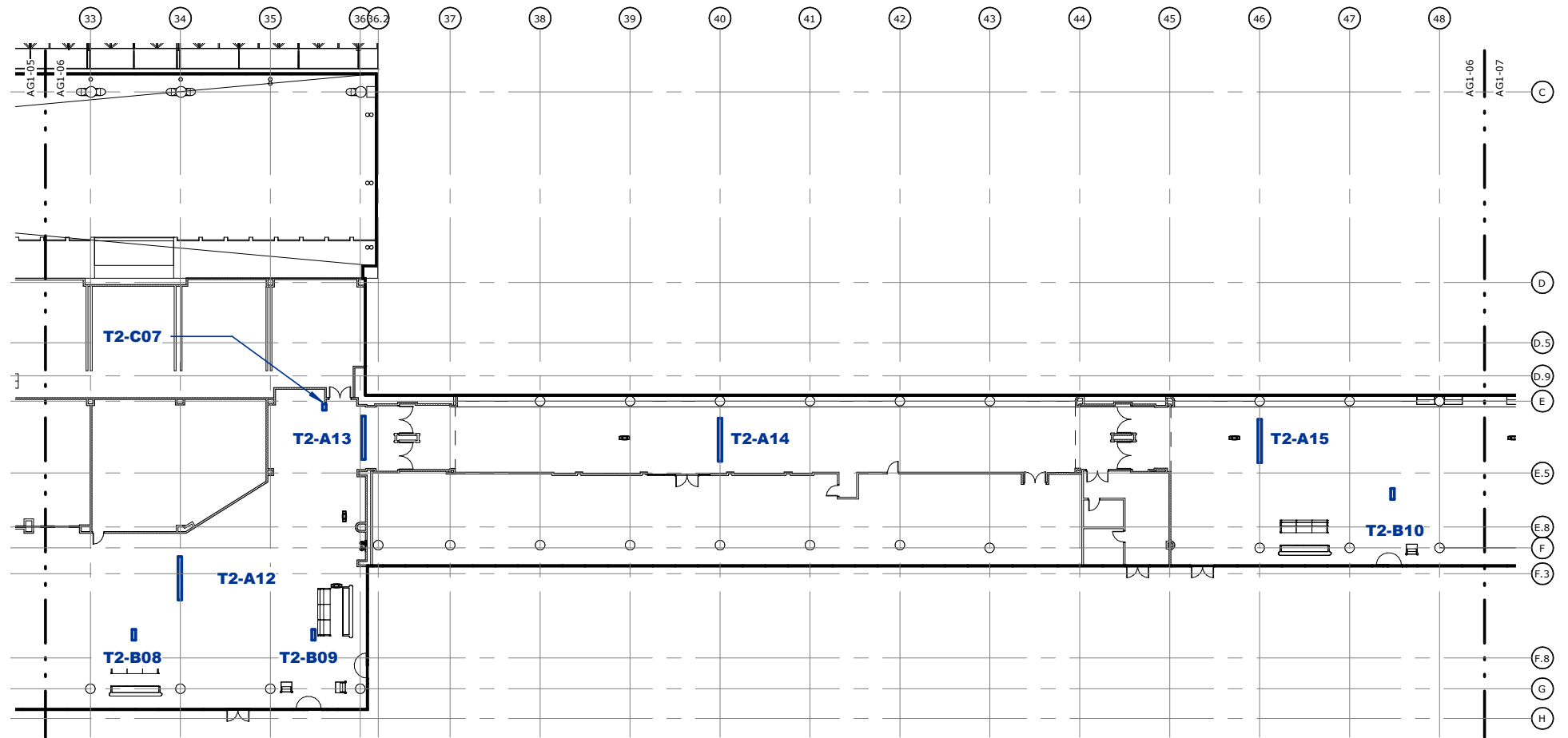
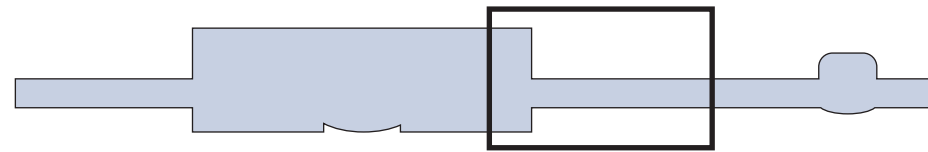

TERMINAL 2 - EAST

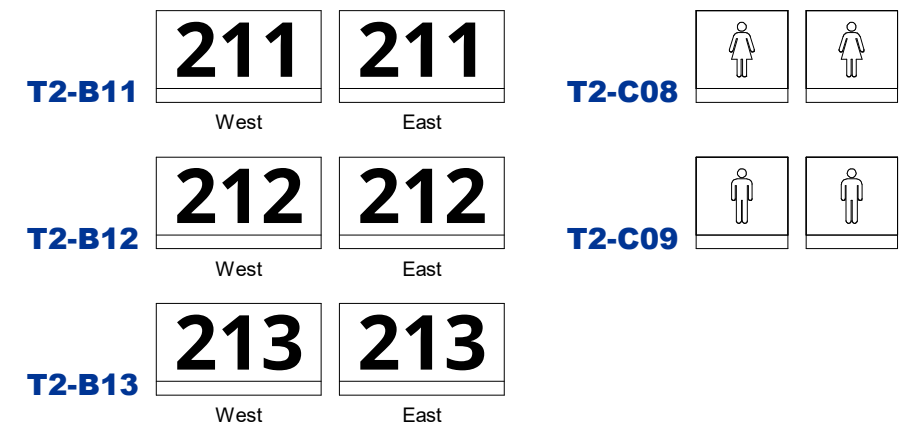
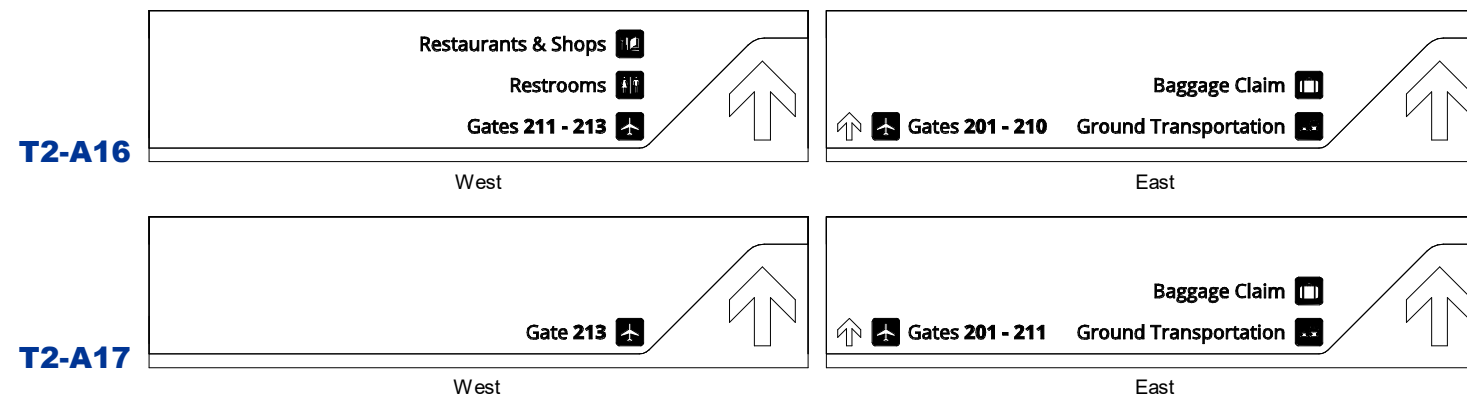
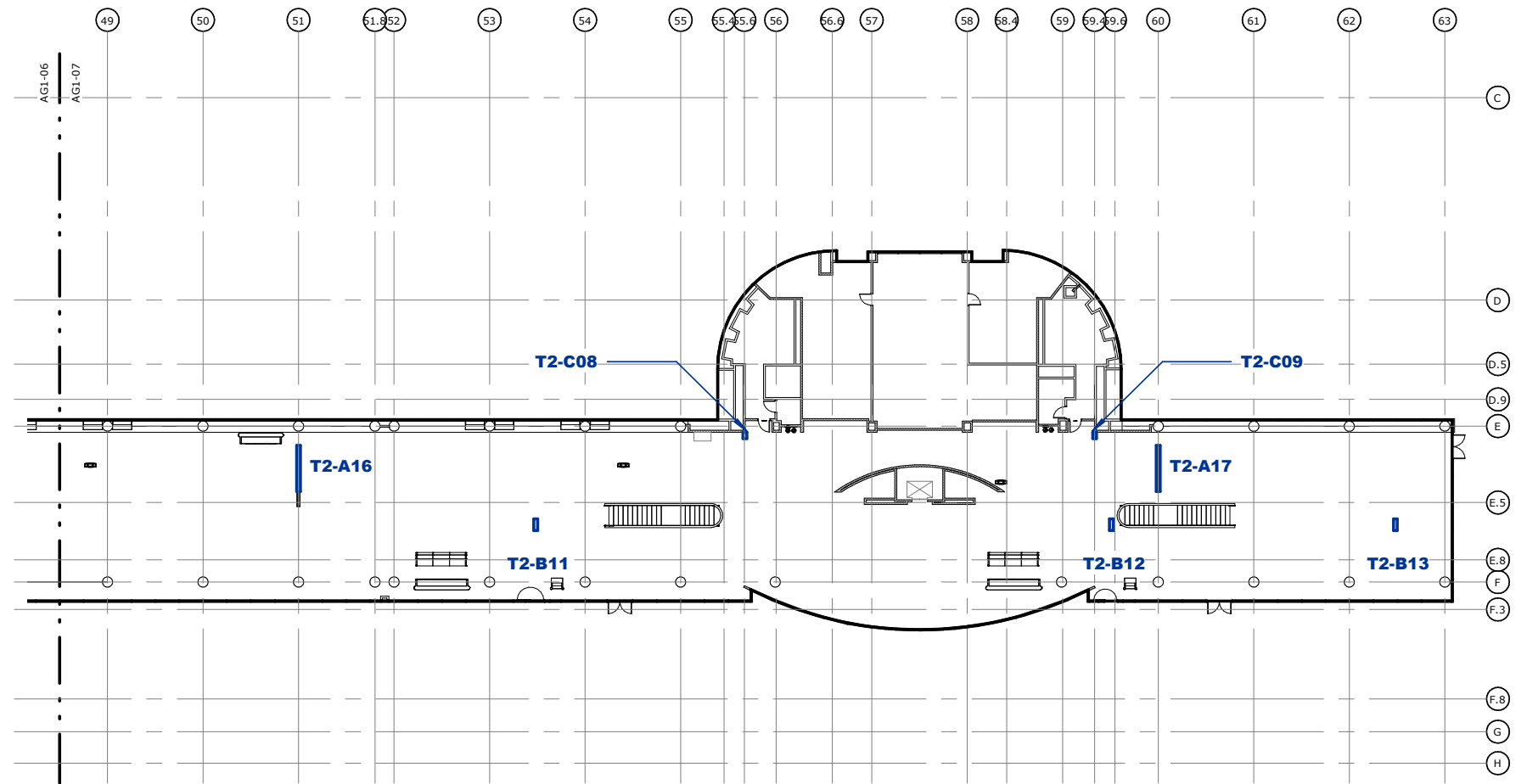
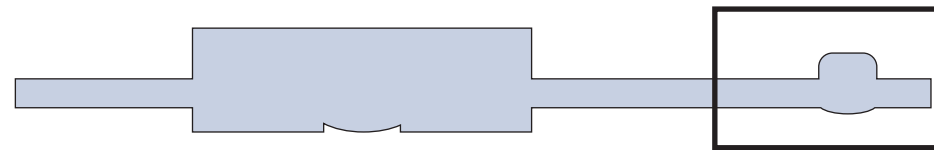

TERMINAL 4 - LANDSIDE - DEPARTURES / ARRIVALS CURB

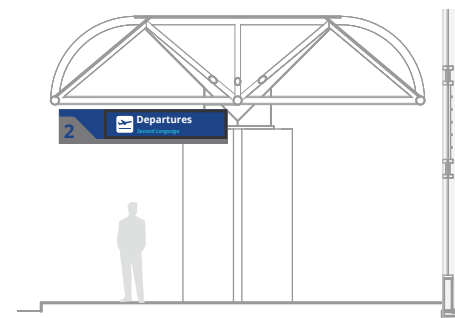
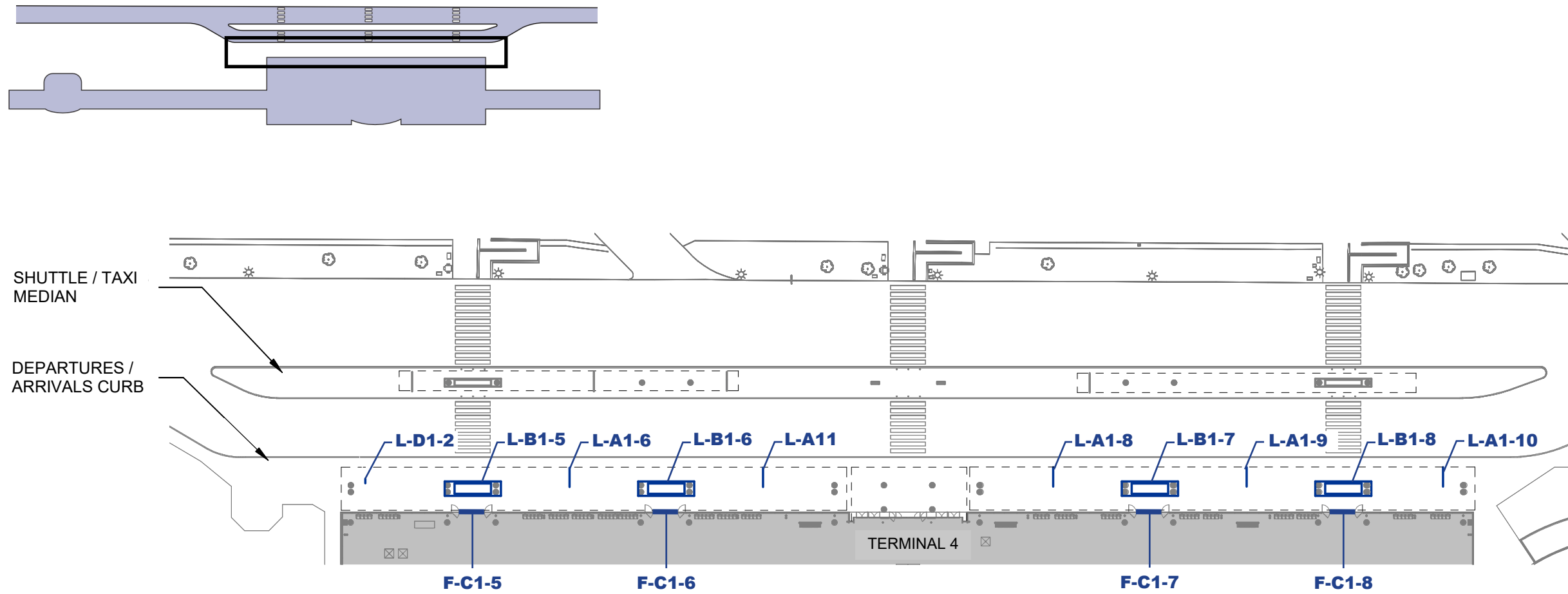

L-A1

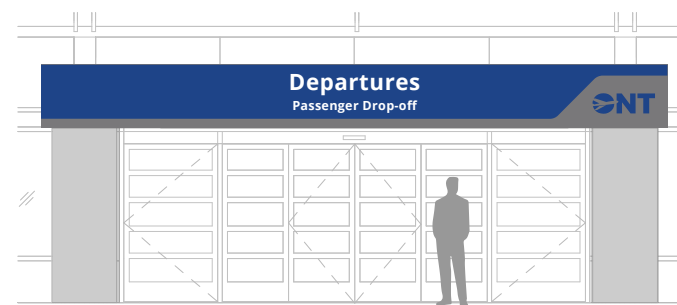

L-B1

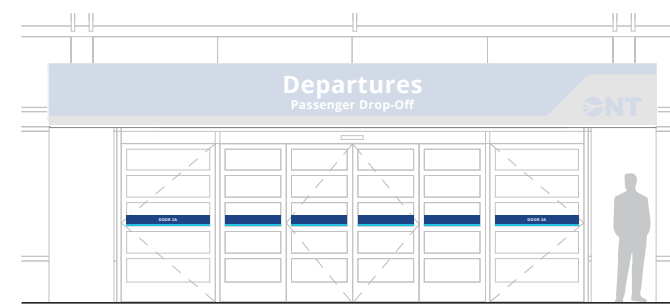

L-C1



L-D1

TERMINAL 4 - LANDSIDE - SHUTTLE / TAXI MEDIAN

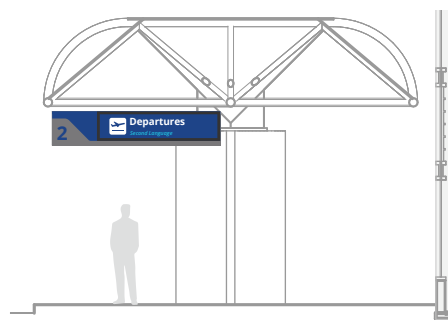
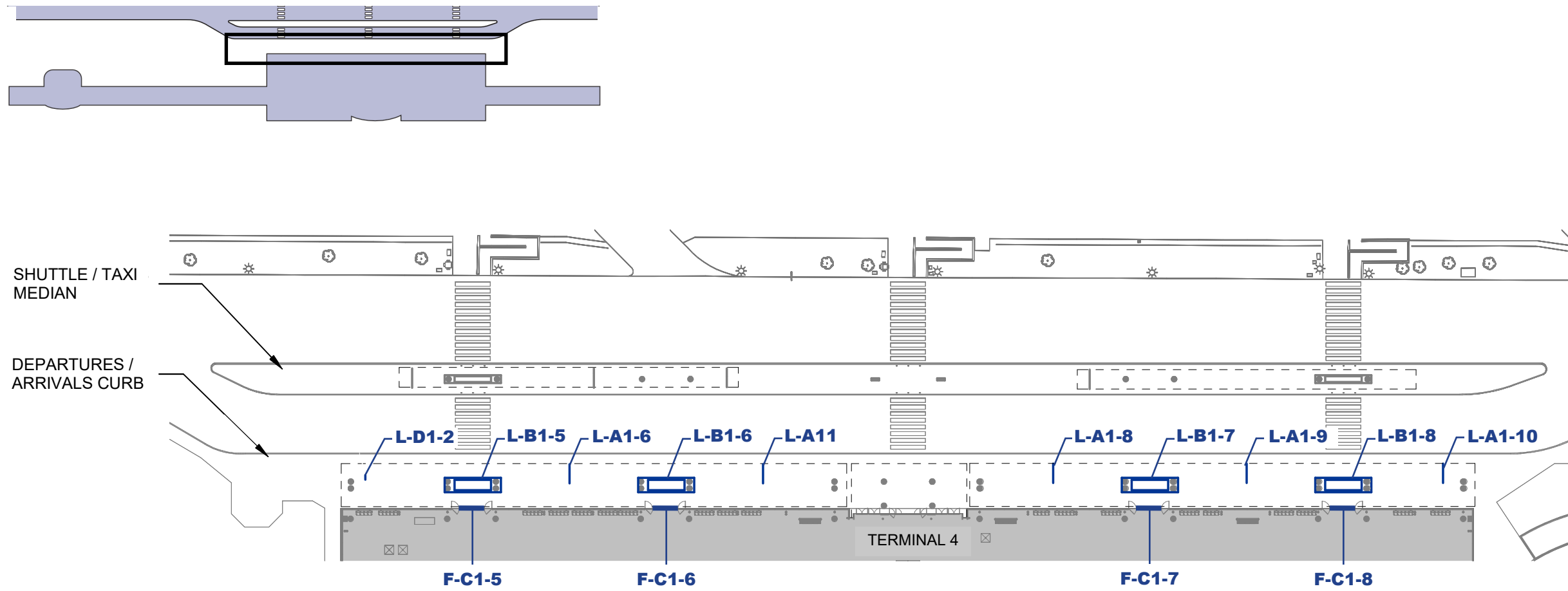

L-A1

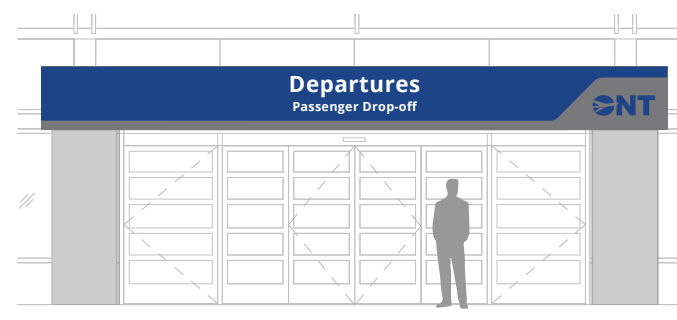

L-B1

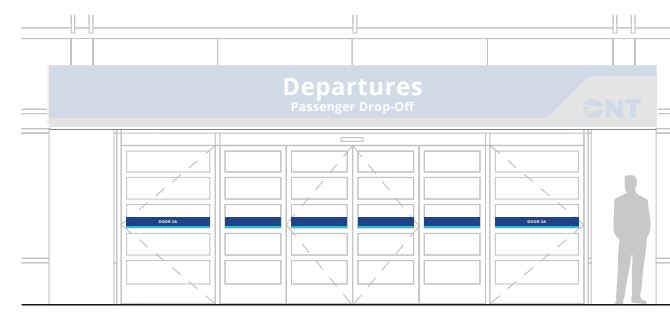

L-C1



L-D1

TERMINAL 4 - LANDSIDE

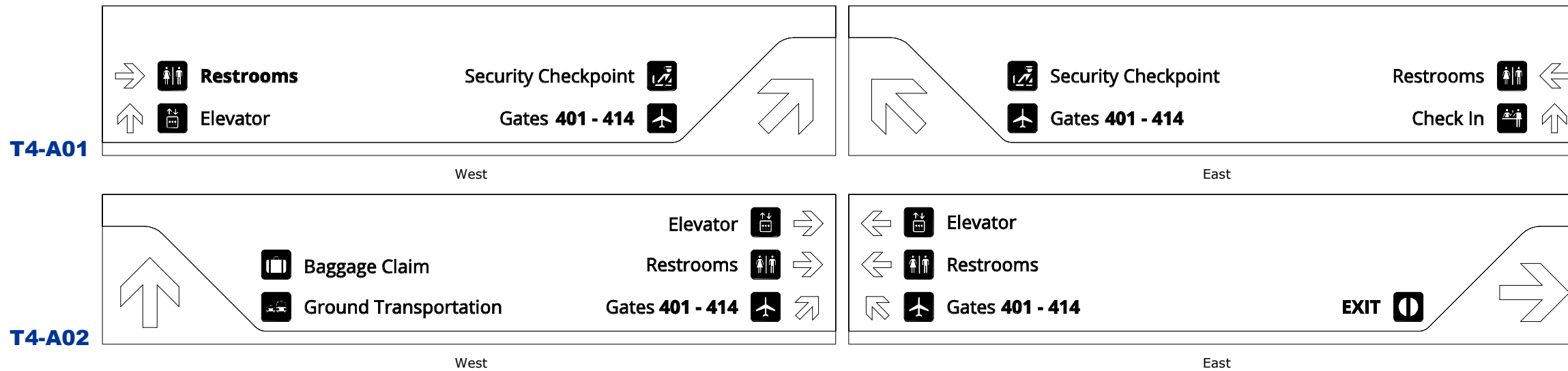
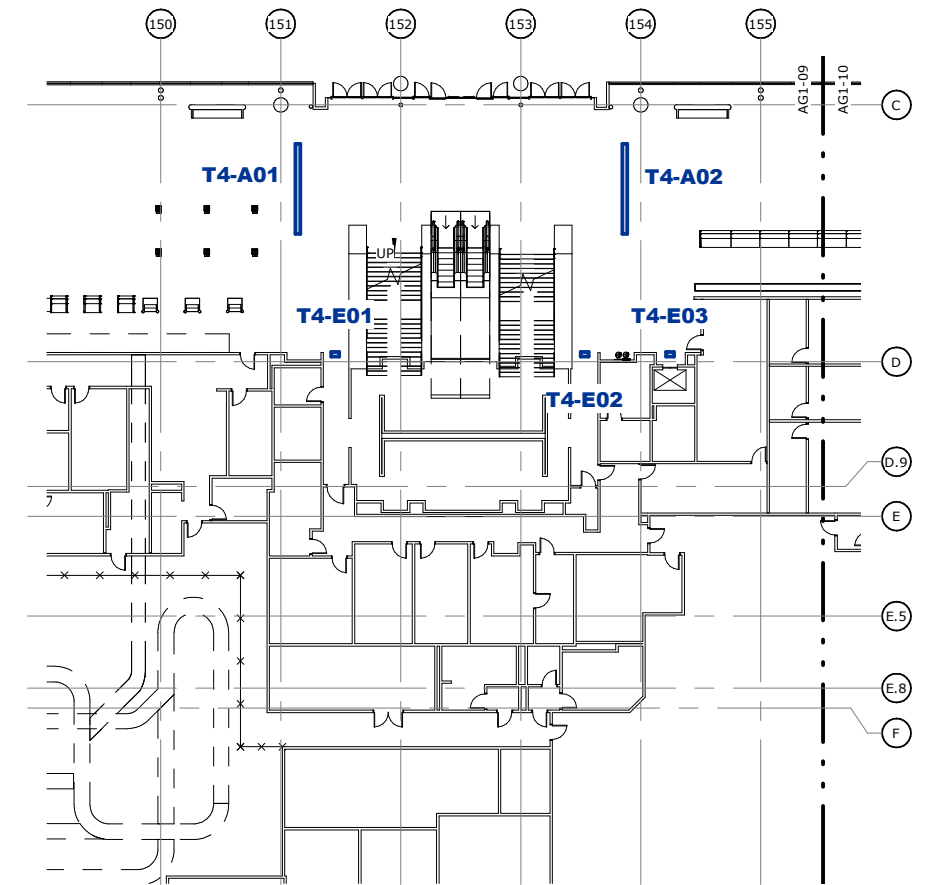
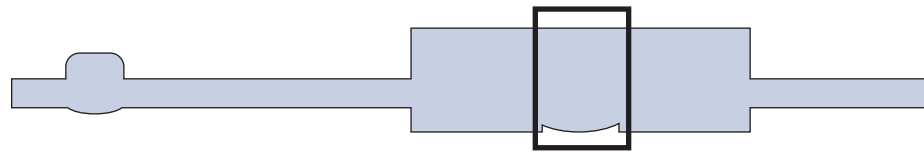

TERMINAL 4 - LANDSIDE

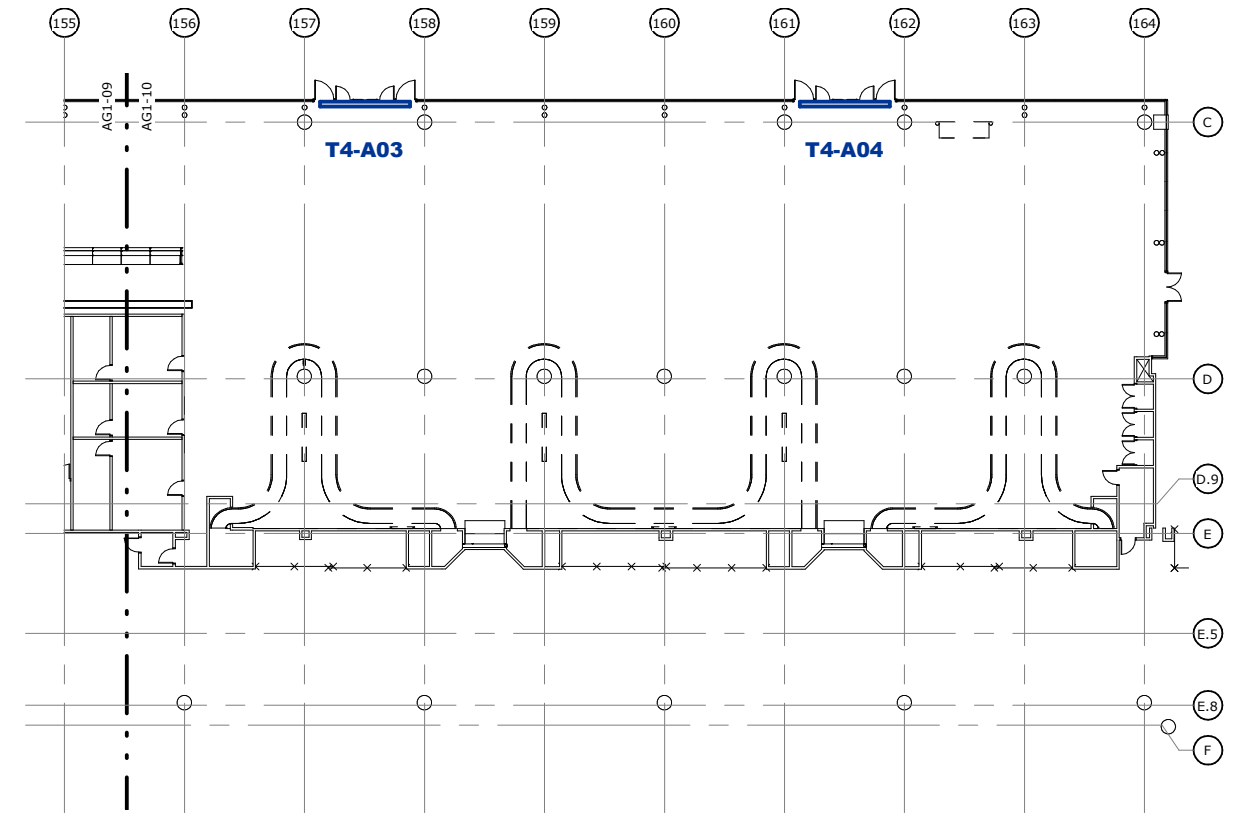
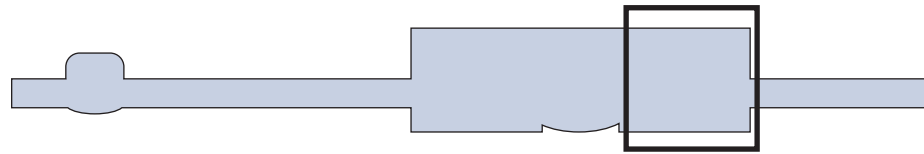

T4-A03

Not Applicable

North

T4-A04

Not Applicable

North

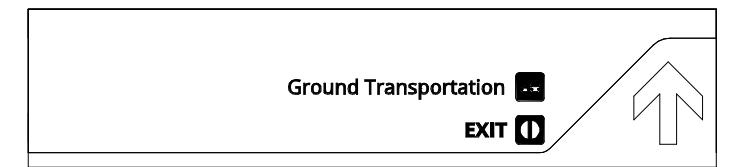

South



South

TERMINAL 4 - WEST

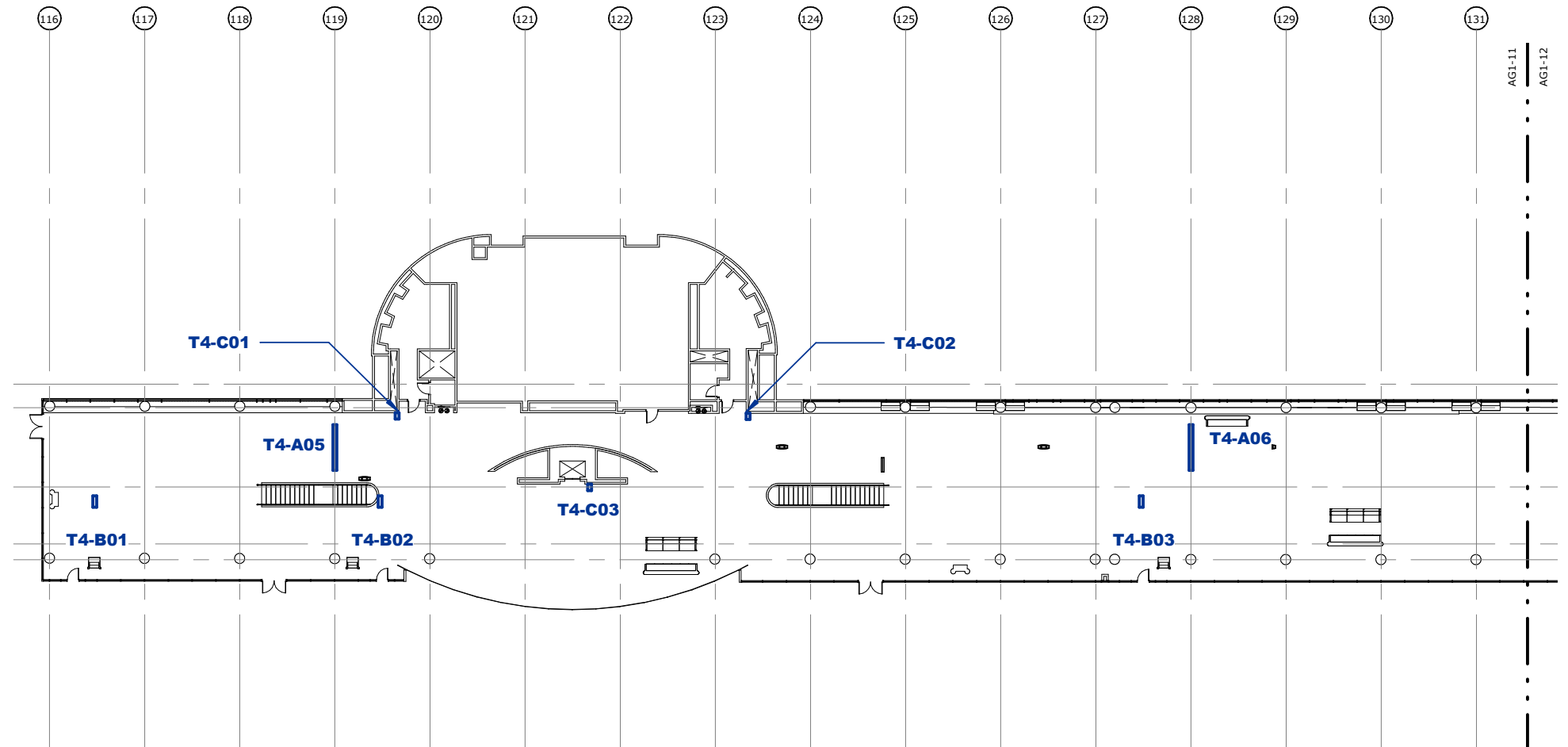
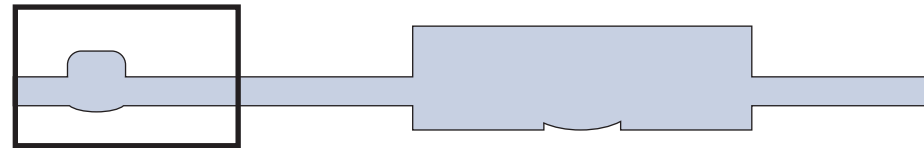

1 - U

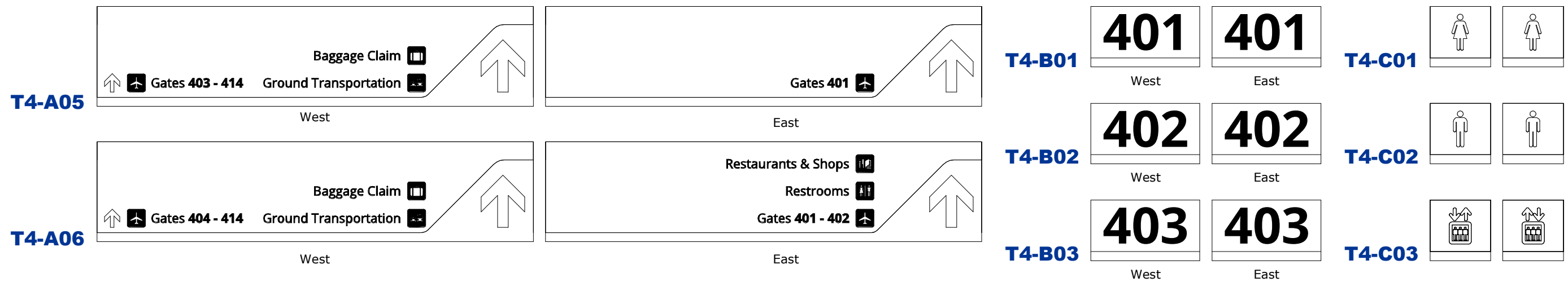

TERMINAL 4 - WEST CONNECTOR

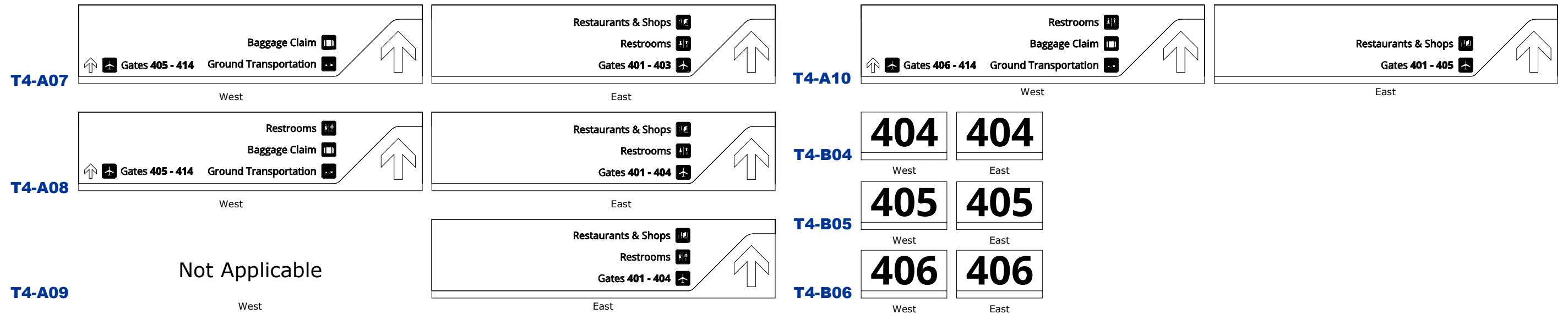
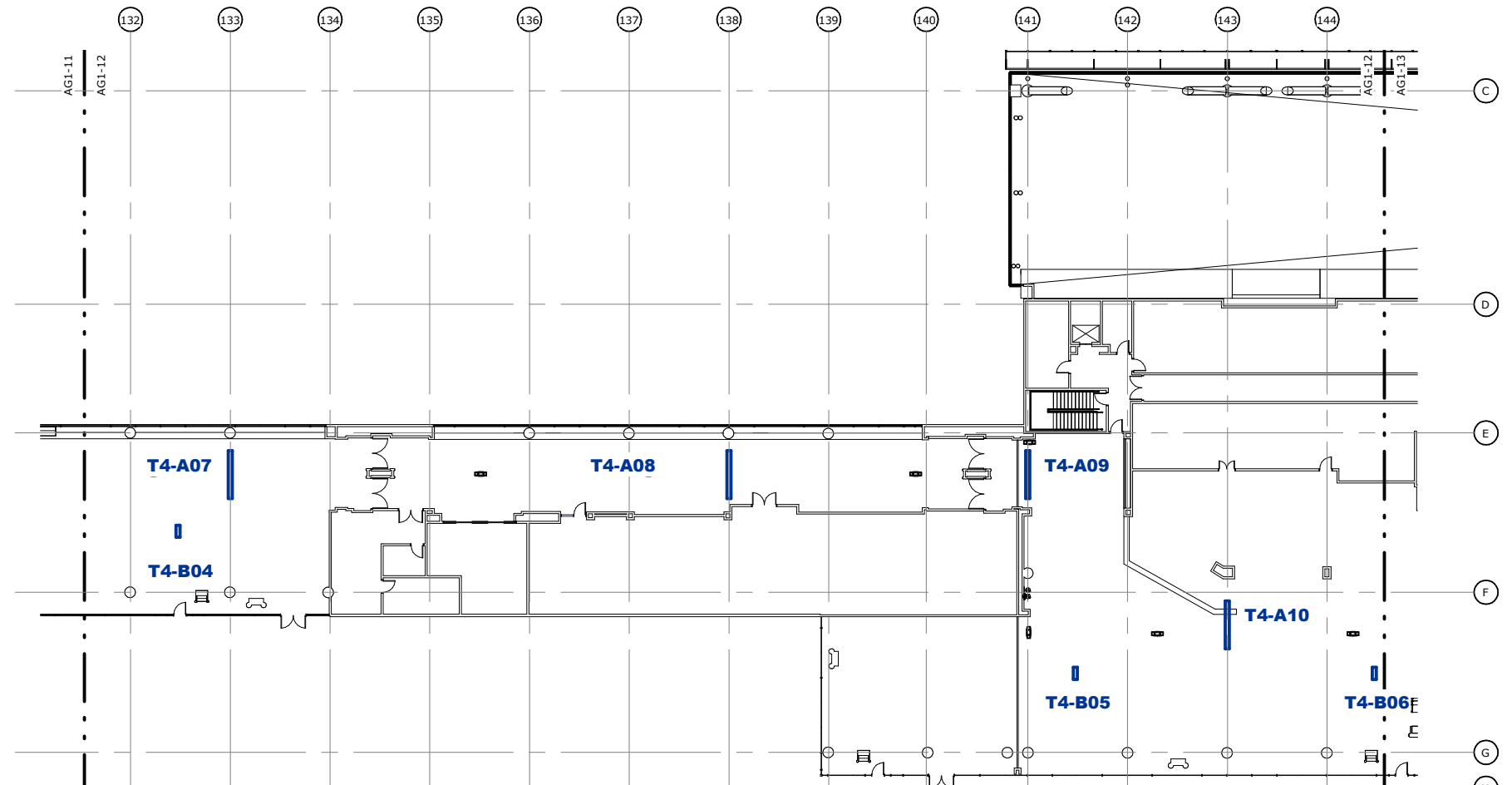
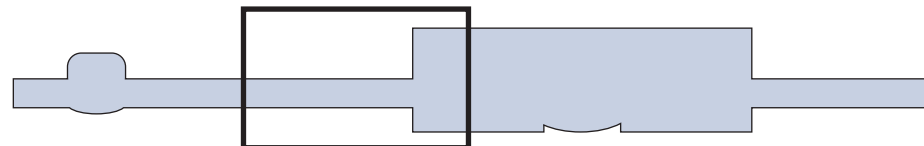

TERMINAL 4 - CENTER

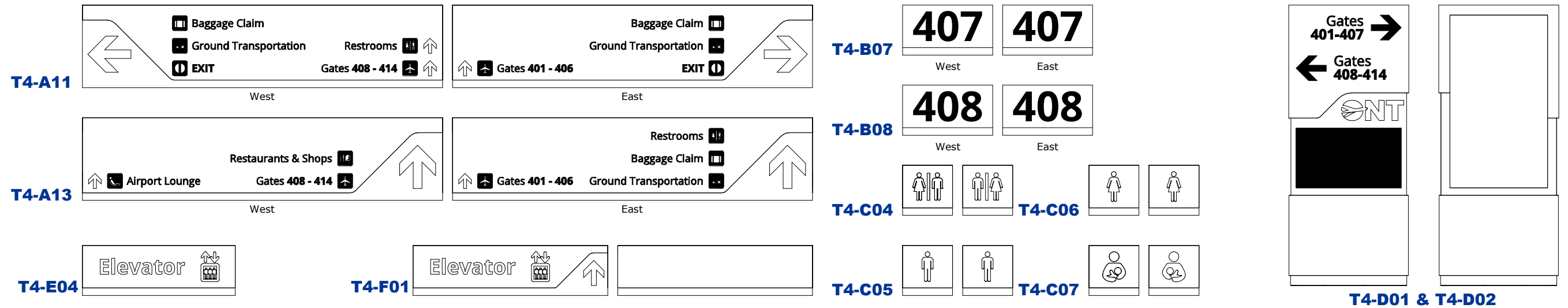
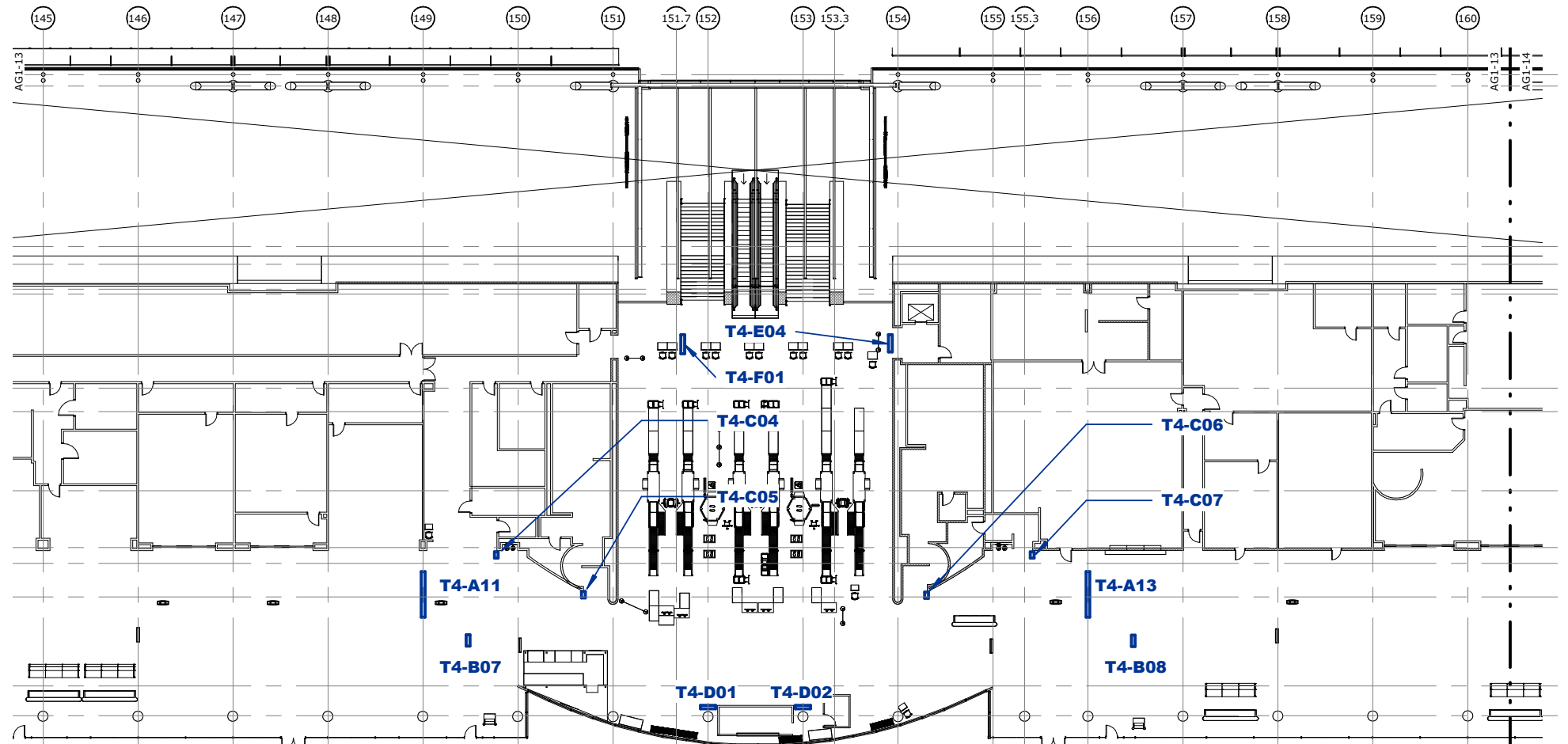
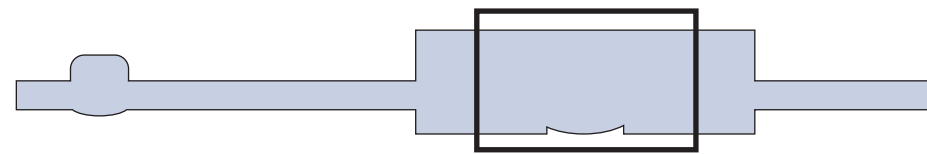

TERMINAL 4 - EAST CONNECTOR

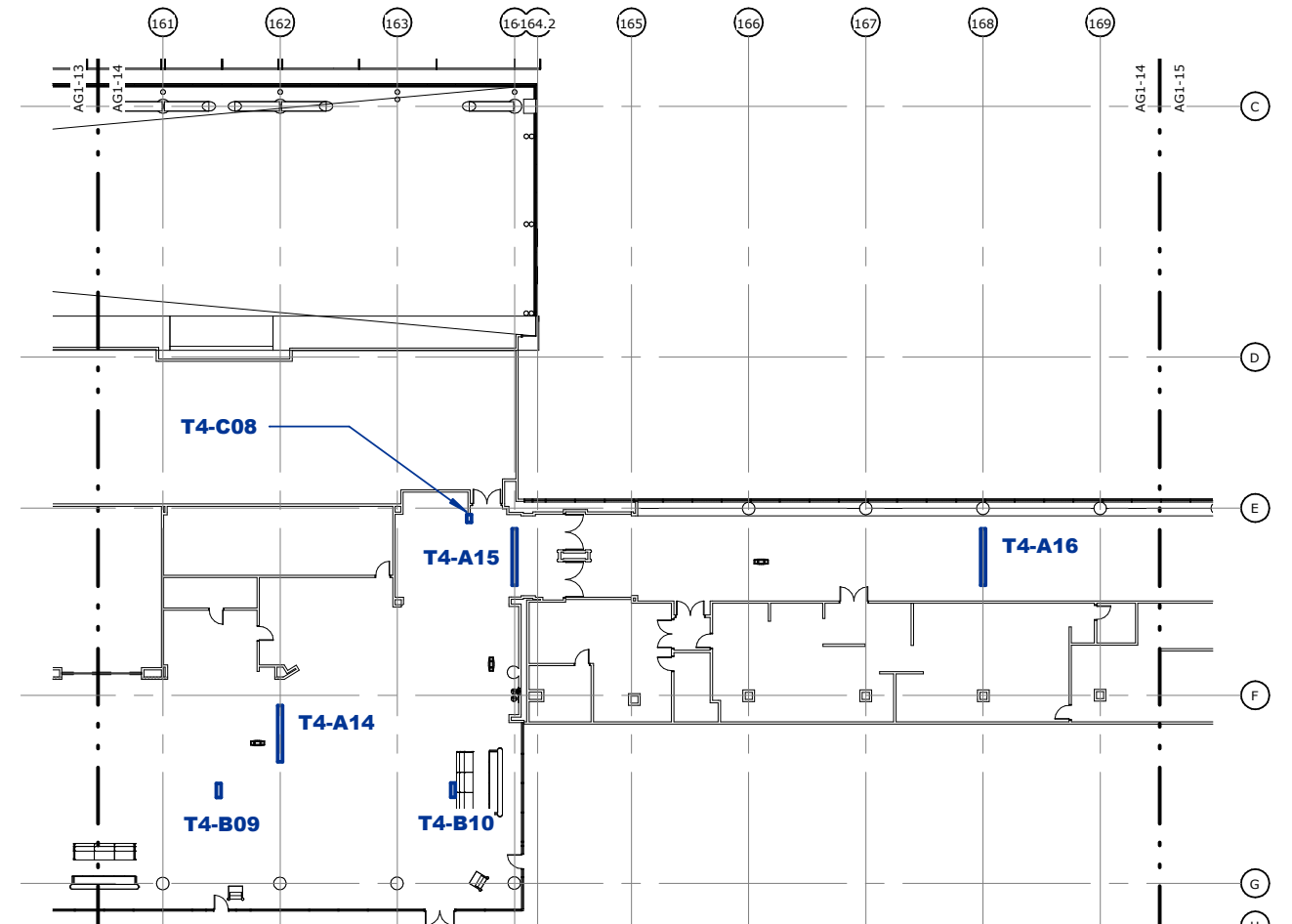
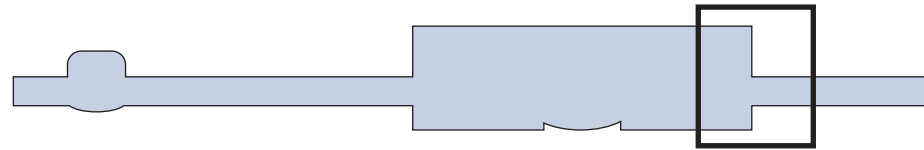

T4-A14	West ↑ Airport Lounge Restaurants & Shops Gates 411 - 414	East ↑ Gates 401 - 407 Restrooms Baggage Claim Ground Transportation	T4-B09 409 West 409 East T4-B10 410 West 410 East T4-C08
	T4-A15	West ↑ Airport Lounge Restrooms Gates 411 - 414	
T4-A16	West Restrooms Gates 411 - 414	East ↑ Gates 401 - 410 Restrooms Baggage Claim Ground Transportation	

TERMINAL 4 - EAST

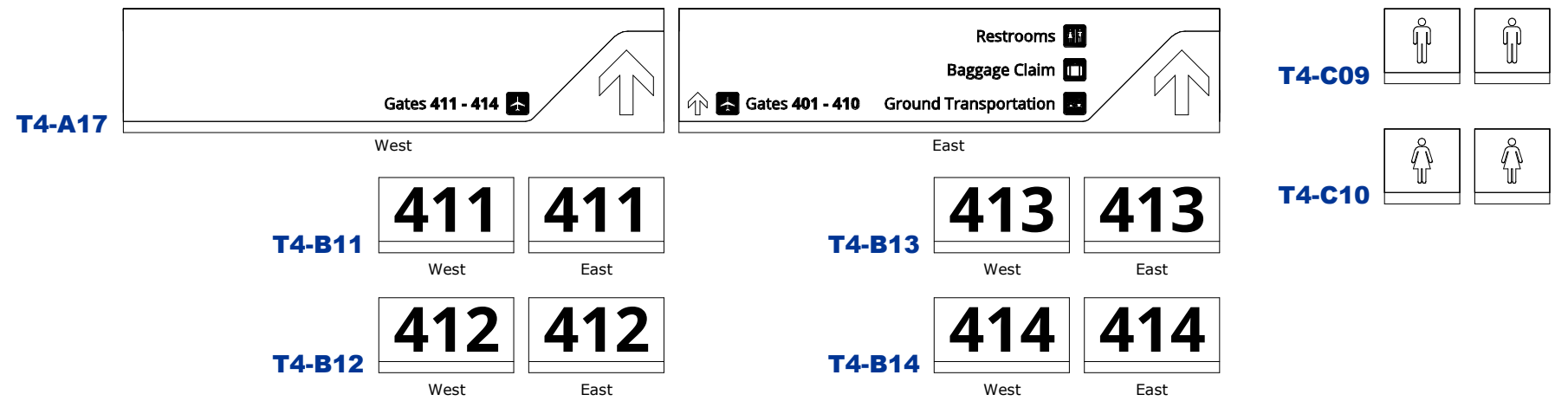
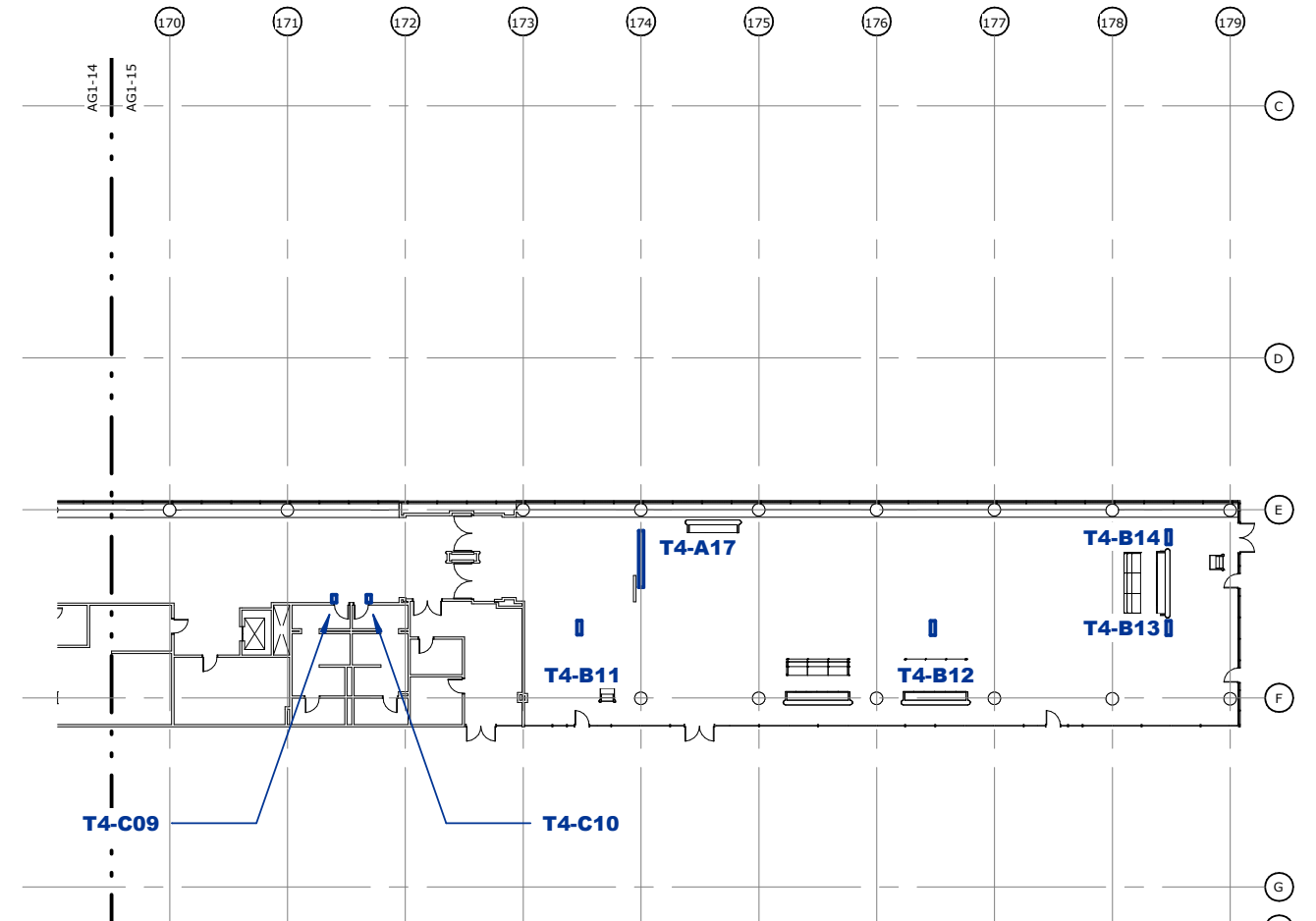
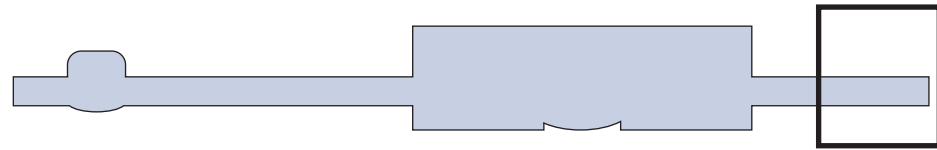

T-A1 OVERHEAD DIRECTIONAL LARGE - CEILING MOUNTED (AXONOMETRIC)

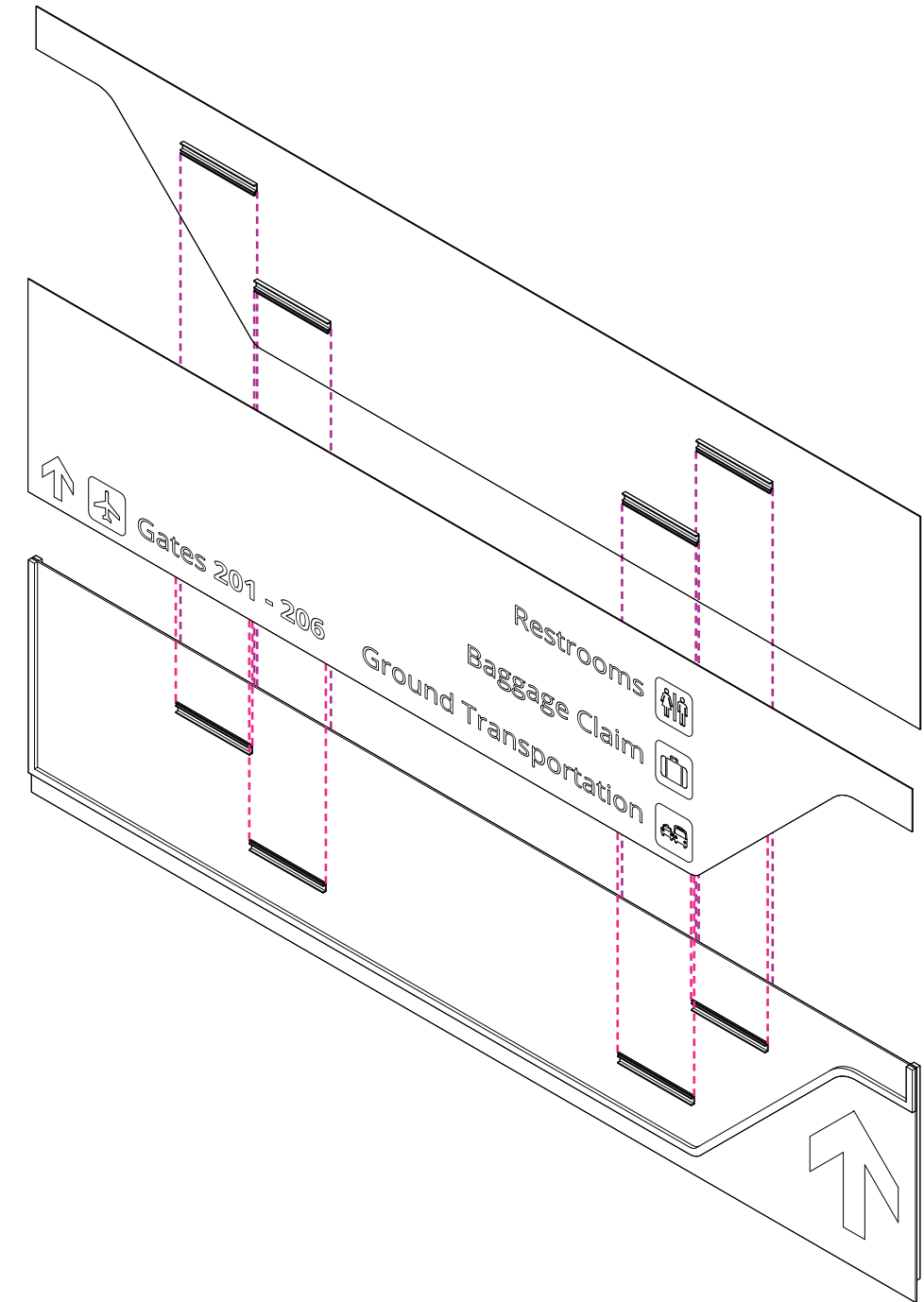
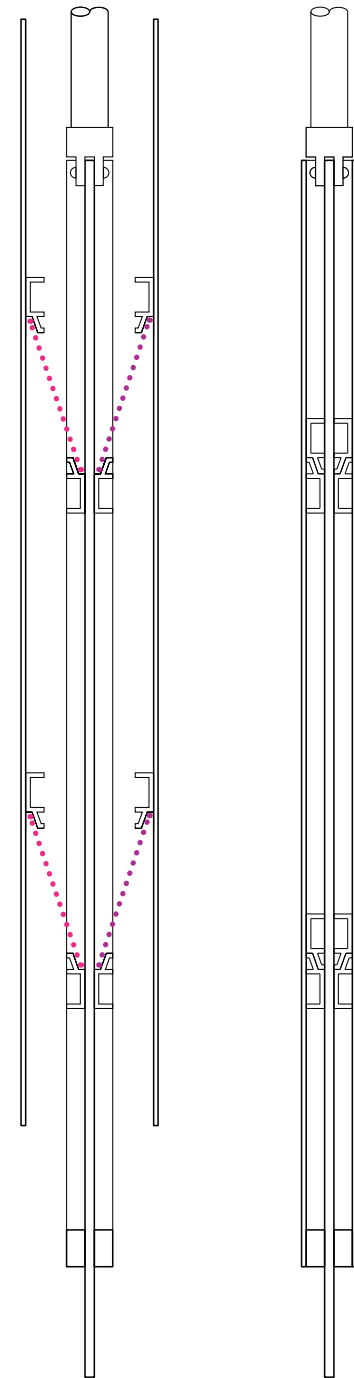

T-B1 GATE ID - CEILING MOUNTED (AXONOMETRIC)

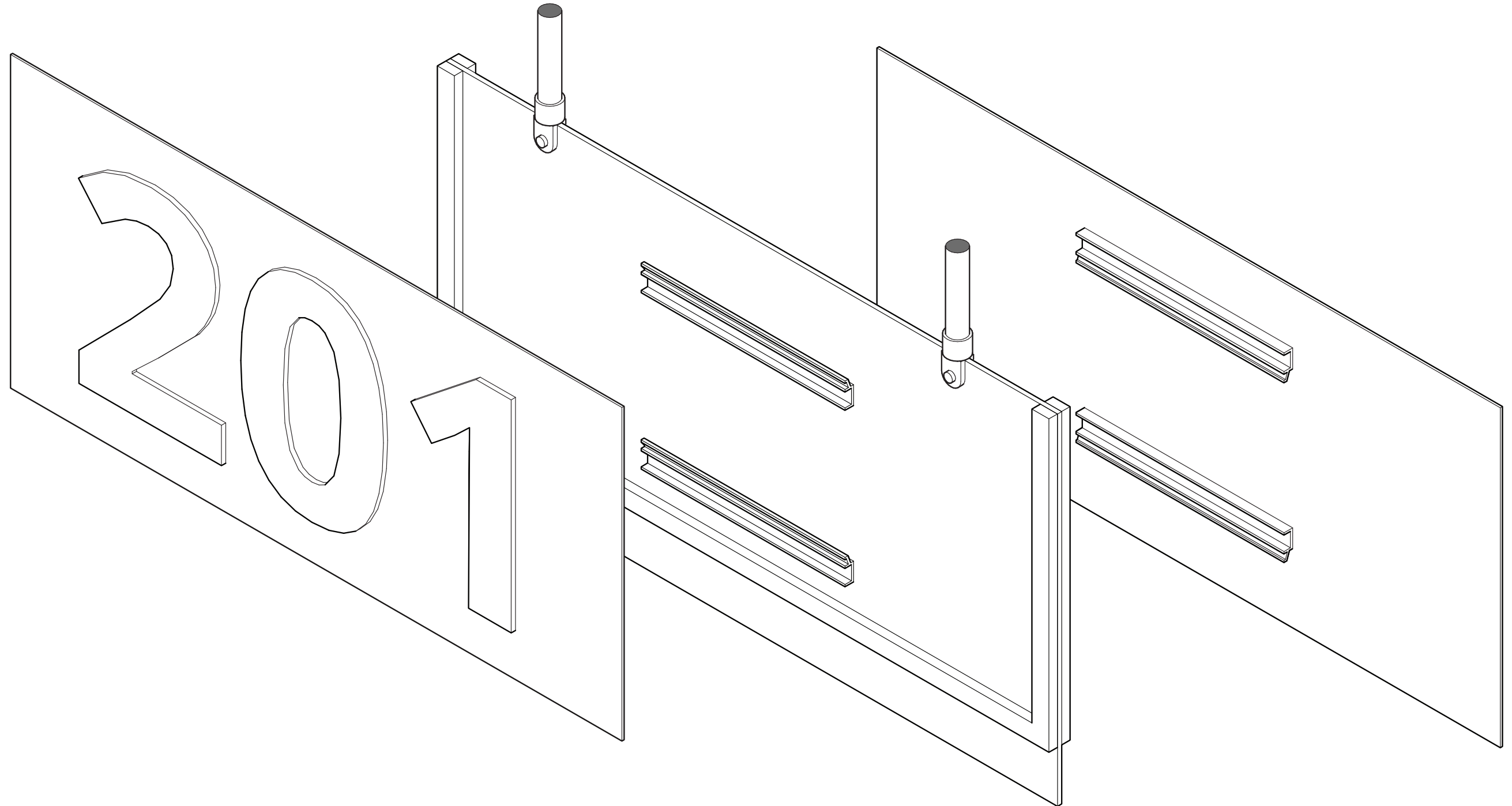

T-C1 SYMBOL ID - FLAG MOUNTED (AXONOMETRIC)

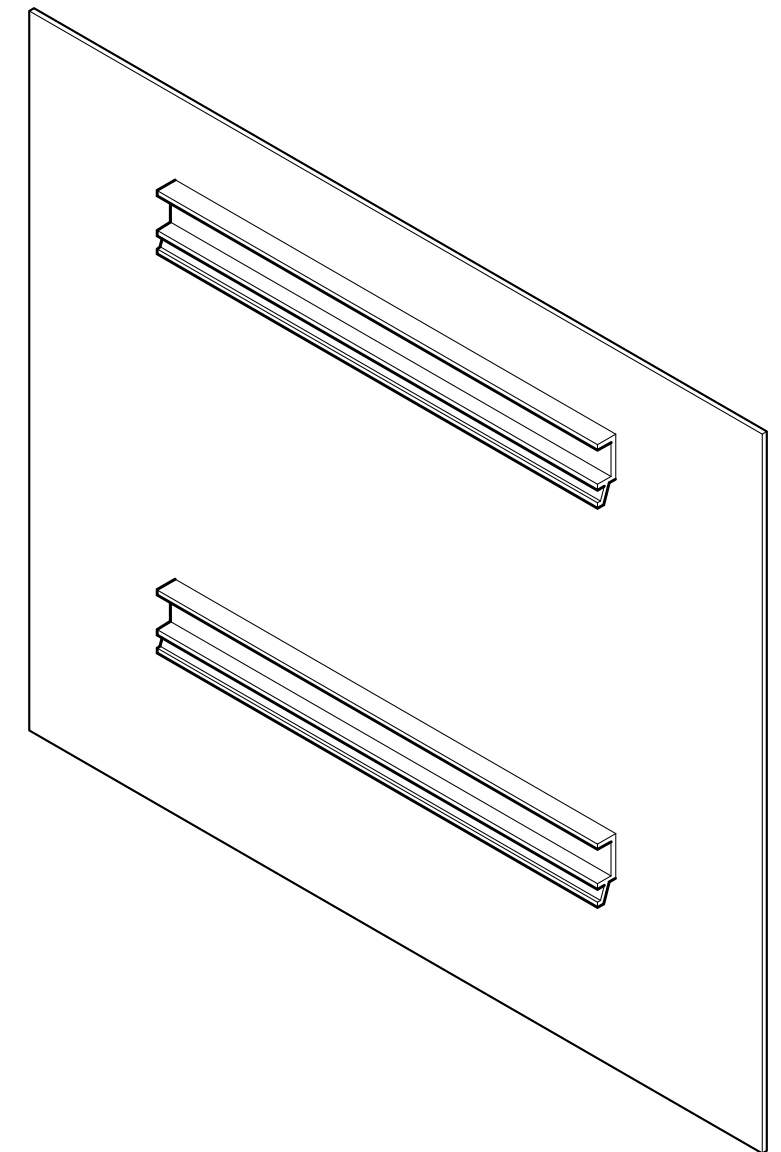
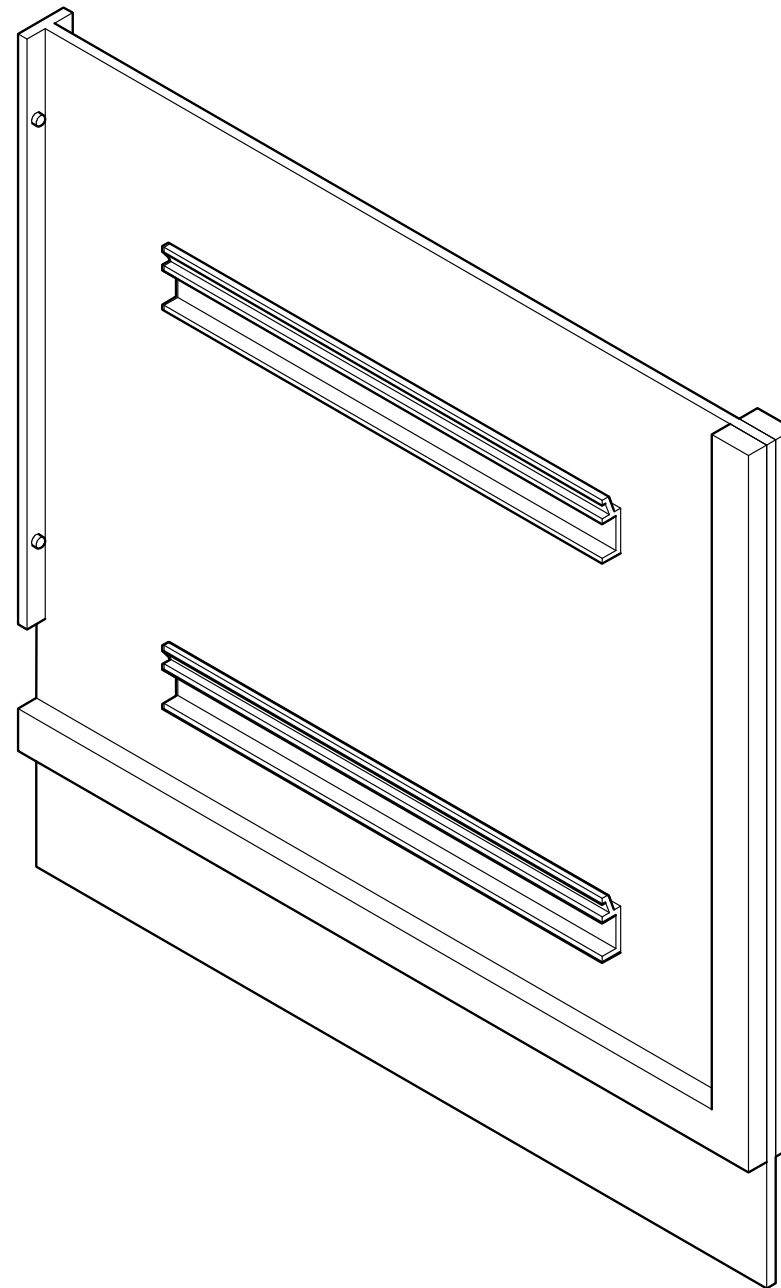
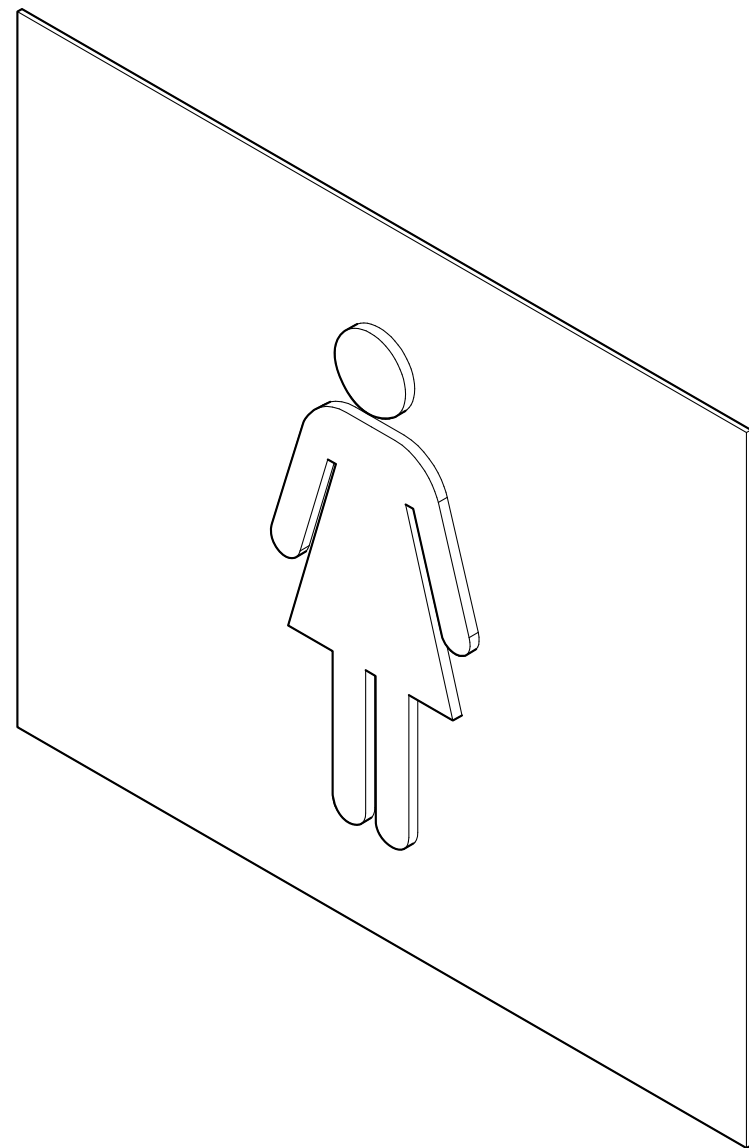

PARKING LOTS

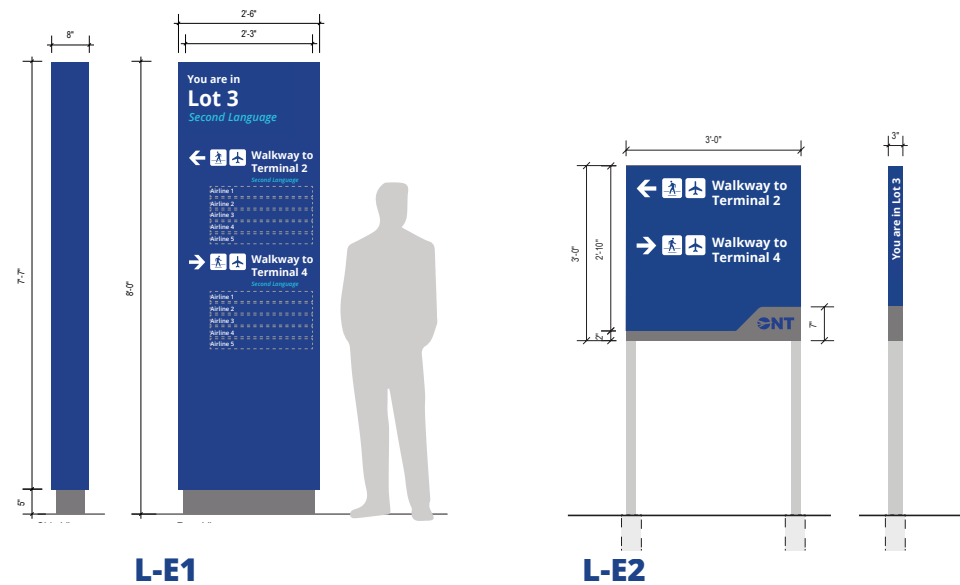
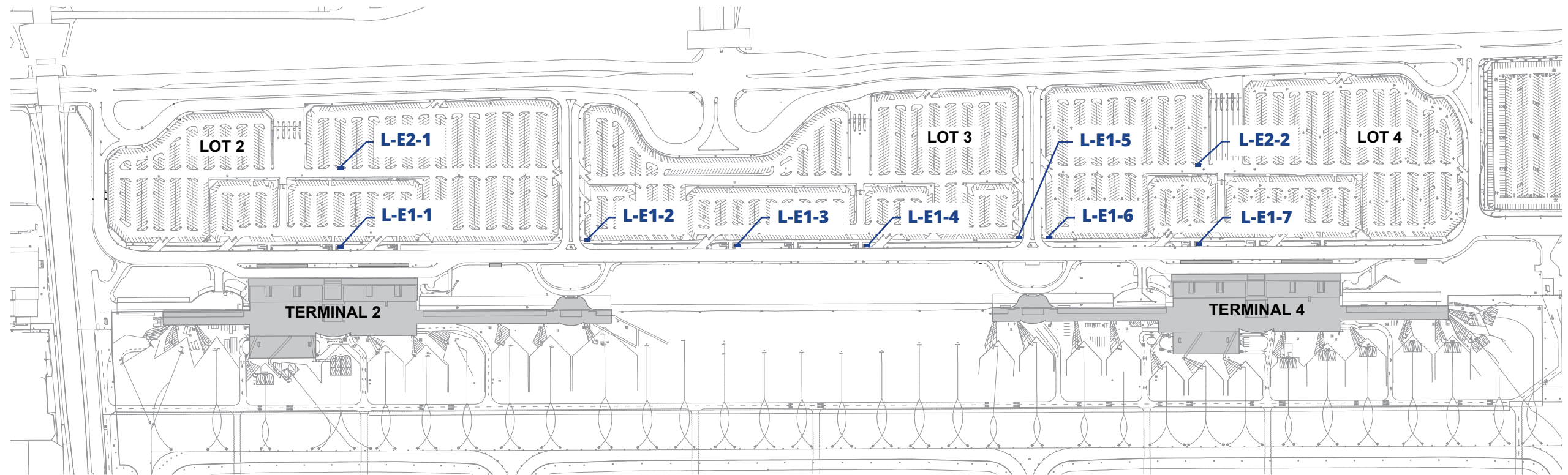

INTERNATIONAL ARRIVALS FACILITY

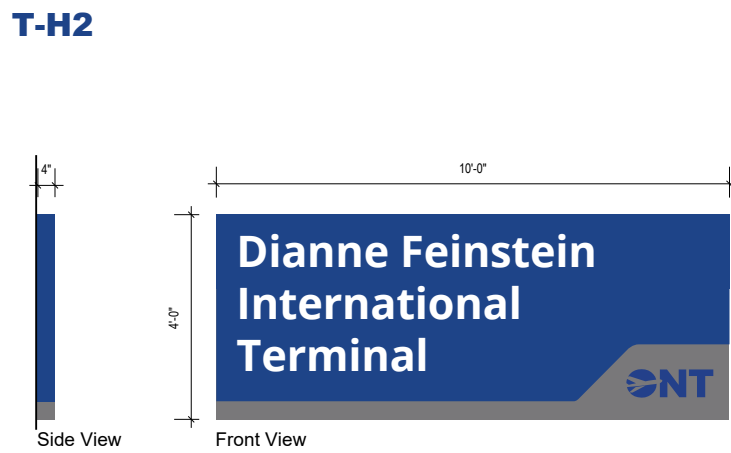
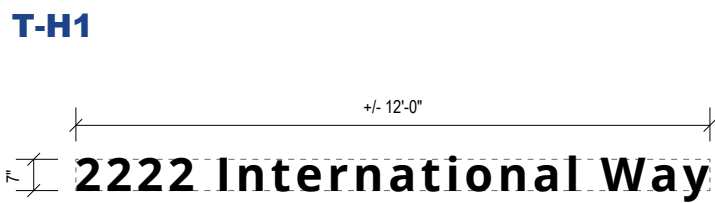

L-F1

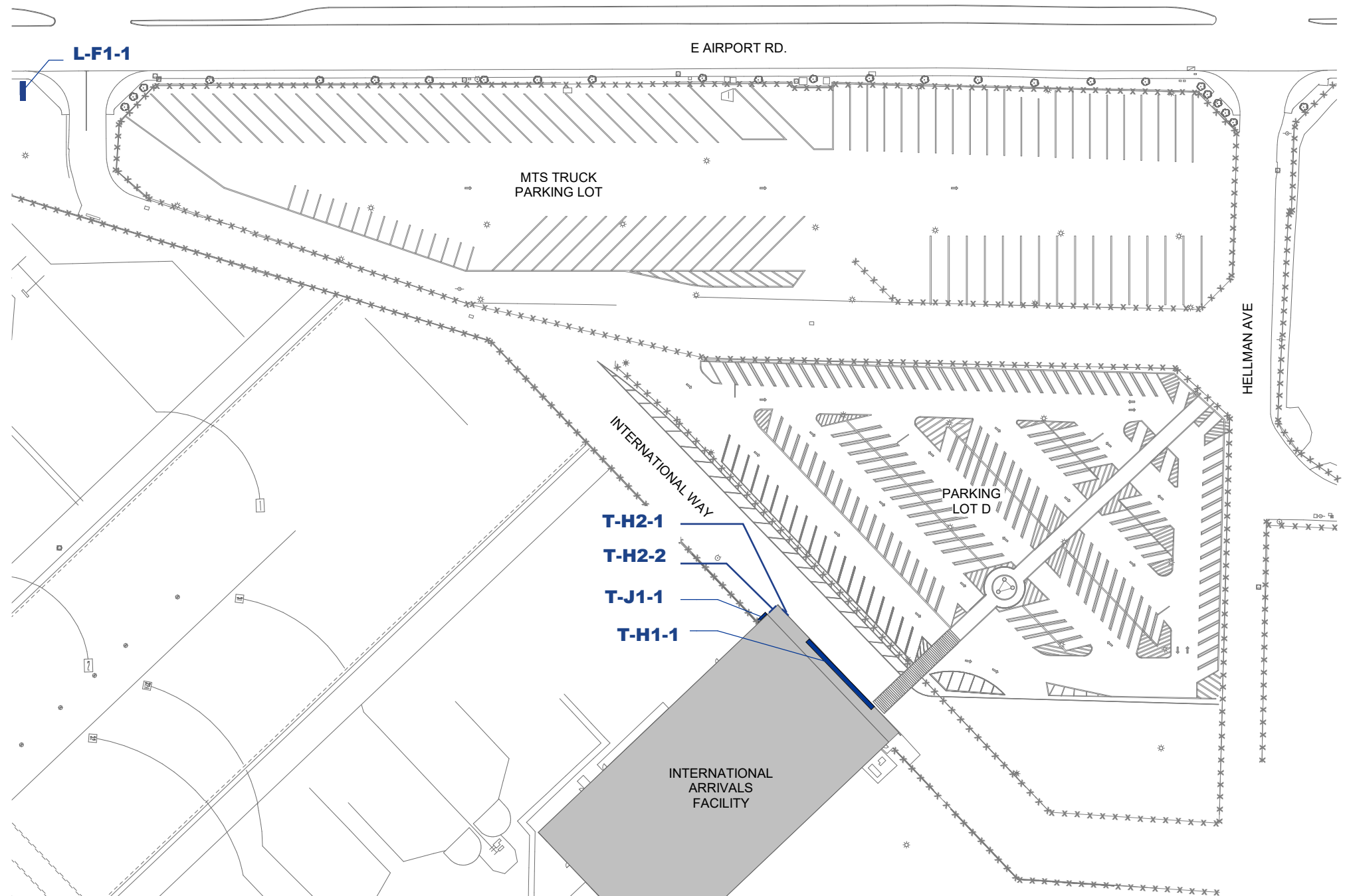

ADMINISTRATION OFFICES

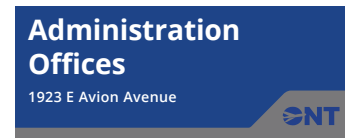

T-J1



F-A1

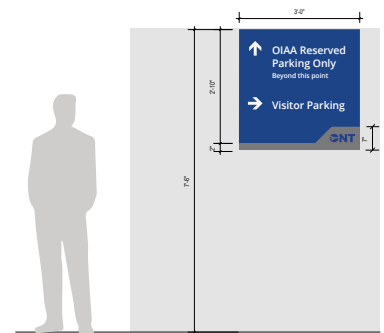

F-B1

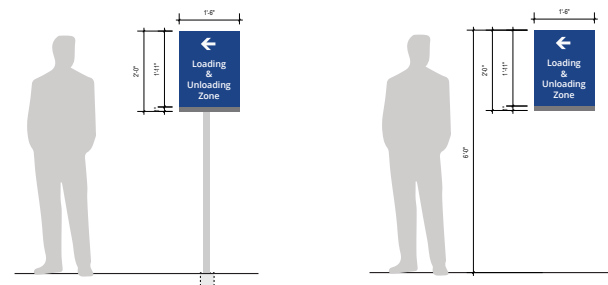

F-B3

F-B2

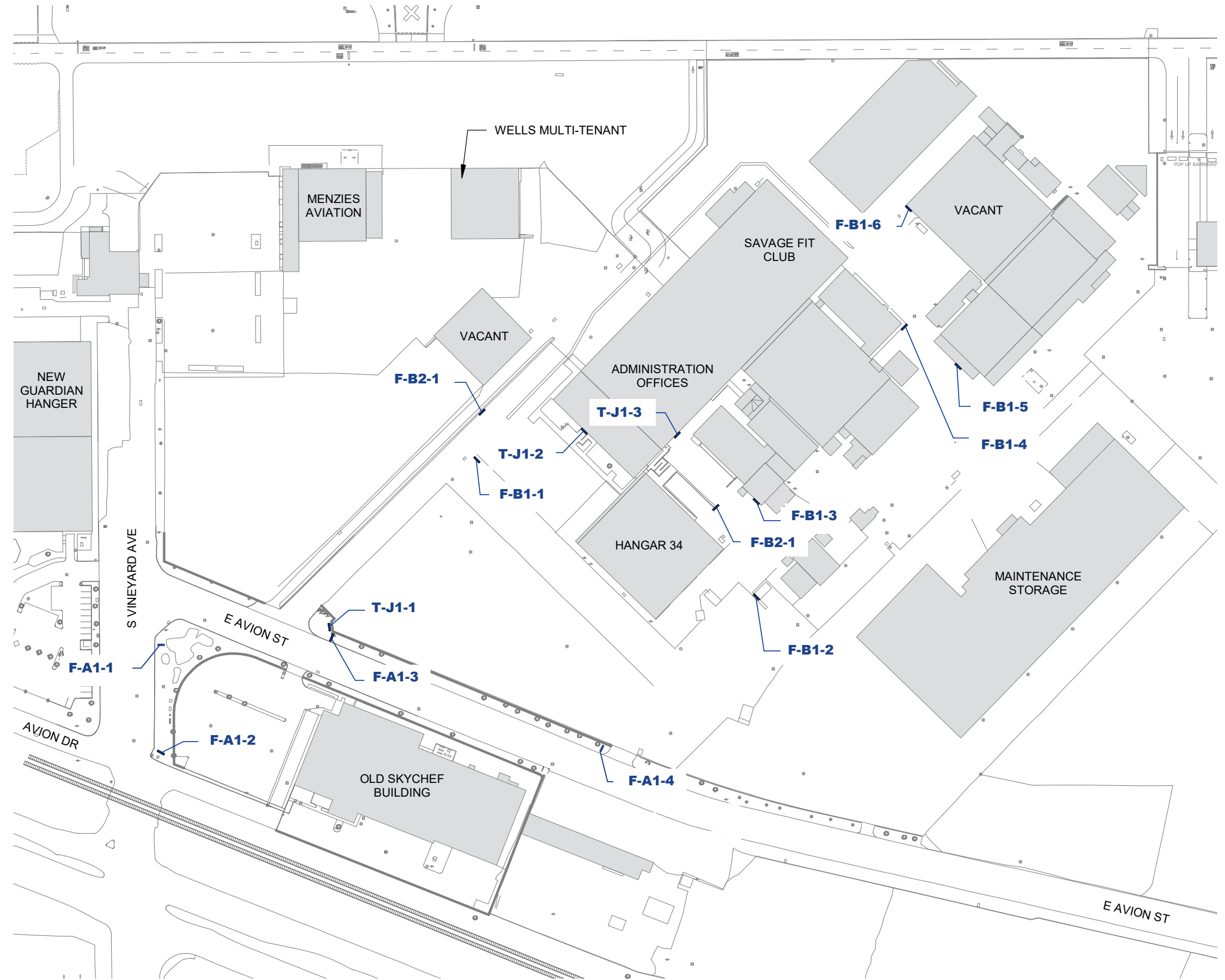

Research Report

Existing Conditions Analysis

A comprehensive review of the existing airport signage system was undertaken to identify potential challenges in location, messaging, and aesthetics. This included an analysis to identify appropriateness, available space, and general conditions of the interior environment. This analysis resulted in five key takeaways:

- Establish a Message Hierarchy,
- Be Consistent with Messaging, Icon Usage, and Color,
- Know When and Where to Emphasize the Brand,
- Find Opportunities for Intuitive Wayfinding, and
- Explore Signage Technology Upgrades.

ESTABLISH A MESSAGE HIERARCHY

It is recommended that the development of a message hierarchy be created to help organize signage messaging. Simplicity is often the best practice but needs to be considered within the context of the passenger journey. What are the passenger's needs and access to information at any particular moment in the journey?

In looking at the current informational organization in the terminal, inconsistencies with the messaging can be seen. For example, on the departures process passengers need immediate reinforcement that they are going the right direction towards their gates followed up with access to ancillary needs such as restrooms, restaurants, and shops. From the arrival's perspectives, immediate reinforcement of directionality to the exit is required.

A message hierarchy will help establish consistency within the terminal. As passengers become familiar with the terminal, they will not need to rely on the primary messaging of the sign but can focus on the secondary messaging to address their needs. Unfamiliar passengers however will need access to this information and expect it to be readily available.

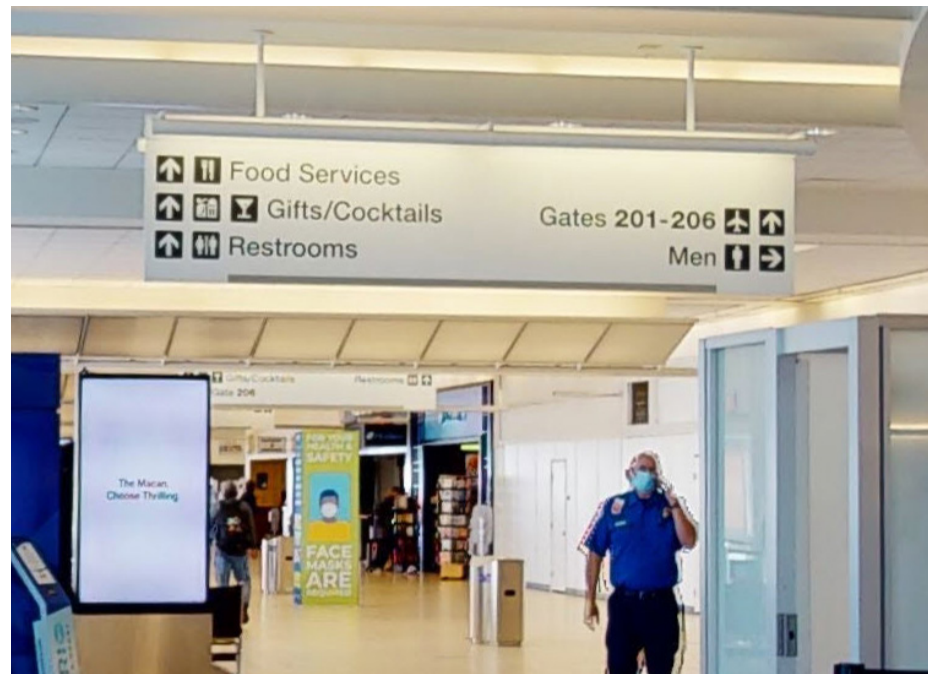

View of Terminal Sign Band on Departures Path showing the lack of message hierarchy



View of Terminal Sign Band on Arrivals Path showing the lack of message hierarchy

BE CONSISTENT WITH MESSAGING, ICON USAGE, AND COLOR

For a wayfinding system as complex as one at an airport, the consistent use of messaging, symbols and color is critical to create a cohesive experience across the Ontario Airport Campus.

For example, throughout the roadway network we see the use of a freestanding pylon. In most instances, this sign is broken into three parts: directional, terminal identification, and branding. However, this message structure isn't consistently applied at all pylons.

Additionally, if we look at how destinations are identified they are not consistently referred to in a consistent manner. For example, Parking Lots are not consistently referred to by their primary identification such as Lot 2, Lot 3, Lot 4 and Lot 5. In some cases, the Parking Lots are referred to by their offering such as Daily Parking, Value Parking or Economy Parking.

Finally, the use of different font styling confuses the message hierarchy. The impact of the sign can be more powerful if the first tier message, such as the Parking Lot Identification, is bold and the second tier message, the parking lot offering, is left in its regular state.



Various views to the freestanding pylon showing inconsistencies with nomenclature and font styling

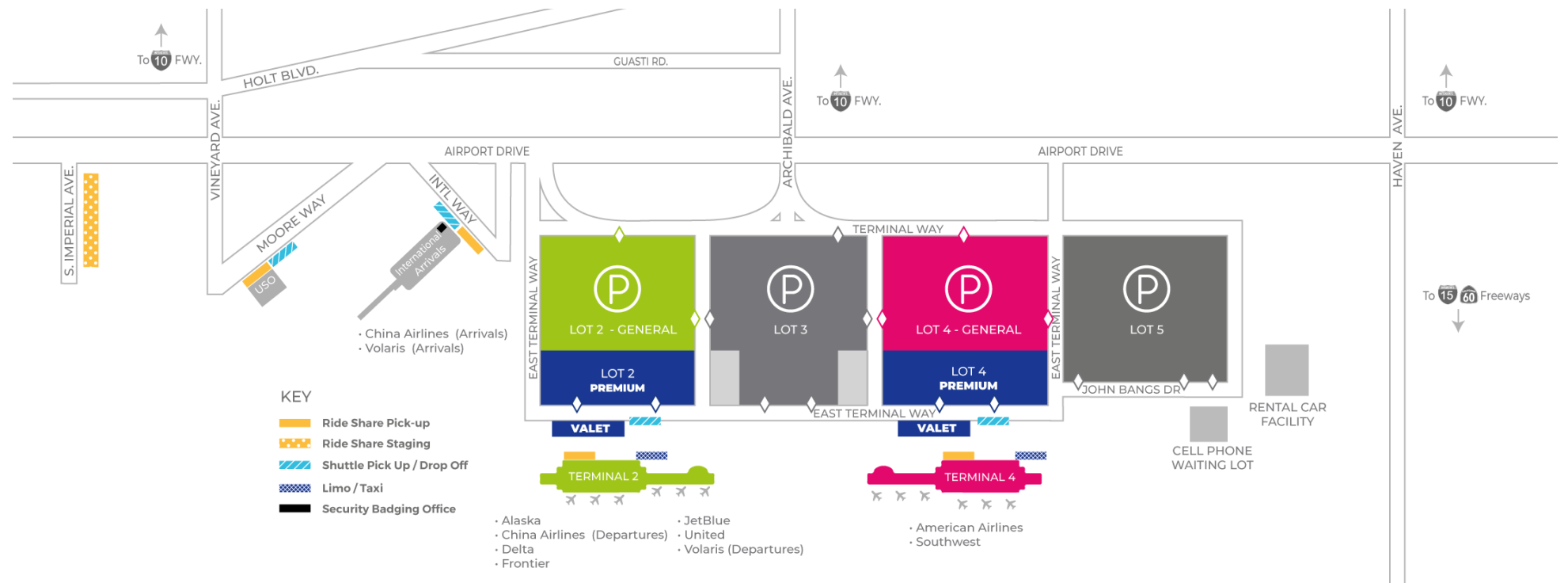

Terminal Map found on the ONT Website showing alternative Parking Lot identification nomenclature

KNOW WHEN AND WHERE TO EMPHASIZE THE BRAND

Ontario International Airport has a strong existing brand strategy that is important to the airport's identity. In some cases, this brand strategy has been applied within the signage program. Throughout the roadway and the curbside, the brand color scheme has been applied to some success and has started to define a signature design element to the signage program. However, there has been an emphasis placed on the ONT logo that could potentially distract from the primary messaging of a sign.

Additionally, the roadway signage has been updated to reflect the ONT branding colors. However, in some instances the contrast of colors can be washed out and critical directional signage may be disregarded because it is too hard to perceive. The design team recommends a merger of wayfinding and branding as environmental placemaking. Building an identity for a place usually starts with a logo, however, a complete wayfinding program offers much more substance.



Various views to the showing usage of ONT Logo on signage throughout the Roadway, in some cases pulling attention from the primary messaging.



The use of branding colors, in the case of this overhead roadway sign, has resulted in the directional areas being hard to read.

FIND OPPORTUNITIES FOR INTUITIVE WAYFINDING

The passenger flows throughout the main terminals are relatively straightforward. There is a critical moment, however, where departing passengers need to orient themselves and decide to go right or left after the security checkpoint. Additionally, this is the moment where arriving passengers need to exit to Baggage Claim or the Airport Exit. This moment is increasingly challenging because of the amount of stimulus that is vying for their attention at this moment: advertising, views to the airfield, concession awareness signage, public safety signage, FIDs, and terminal wayfinding.

It is at this moment that the design team recommends finding opportunities for intuitive wayfinding. Intuitive wayfinding is spatial problem solving that focuses on using the design put forth in the architecture and interior environment to communicate to users where they are, where they want to go, and their pathway to get there. Incorporating this strategy will be critically important at moments like the orientation moment described above. In particular because, intuitive wayfinding will help combat inattentive blindness, in inability to identify stimulus, such as signage, in plain sight because the architecture and interior environment is reinforcing the wayfinding program.



View at Orientation Moment post-security showing constrained spaces and various concourse stimuli

EXPLORE SIGNAGE TECHNOLOGY UPGRADES

Much of the existing signage at Ontario International Airport is static signage that is front lit by and attached light fixture. Previous studies done by Corgan have indicated that back lit signage has the capability of drawing more focus from a passenger audience than that of non-back lit signage. This can be particularly challenging if a non-back lit terminal wayfinding sign band is adjacent to a back lit advertising panel.

The design team recommends exploring technology upgrades including basic upgrades such as back lit signage. Dynamic digital signage is an option to consider, however in some cases digital signage can increase the perceived busyness of a space and thus negatively impacting the perceived simplicity of the experience. Additionally, content management solutions would need to be incorporated into the day-to-day workflow for the stakeholders responsible for signage.



View of signage showing light fixture attachment

Passenger Behavior Analysis

In order to best support Ontario (ONT) International Airport’s wayfinding experience through a new signage program, Corgan conducted qualitative and quantitative research studies to analyze passenger behavior at the airport. Insights and recommendations from our research, will tailor a custom sign package to ONT’s passengers that emphasizes a strong sense of place in the Inland Empire.

EXECUTIVE SUMMARY

Through a mixed methods research approach using semi-structured user interviews, social media listening, secondary research into cognitive science and behavioral economics, and quantitative validation through ASQ data review and an e-newsletter subscriber survey creation, we identified four key personas that represent ONT passenger needs, motivations, pain points, and goals across the O&D, catchment, and visiting passenger user groups:

- Victor, a catchment passenger in the I.E. who “sometimes shops” at ONT,
- Carla, a nearby O&D local who pays for convenience to offset her anxiety and lack of familiarity with flying,
- Mike, an unfamiliar visitor who connects into ONT instead of LAX by happenstance, and
- June, a knowledgeable visitor who grew up in the area.

Thorough analyses of these personas and user groups revealed that ONT’s overall competitive advantage is the passenger experience. As a recognized part of the Inland Empire regional identity, ONT is highly regarded as convenient, fast, and easy with a strong emphasis on customer service. Within these high-level experiential positives, we identified value in ONT’s small, manageable size and simple terminal layout, quick security checkpoint and lack of crowding, beautiful scenery, cleanliness (especially valued and remarked upon by visiting passengers), proximity to LA and other nearby points of interest,

short commute to most parts of the I.E., reasonably-priced and accessible parking, and generally positive overall passenger journey support.

That said, competitive analysis through catchment area interviews acknowledged that ONT also faces disadvantages in the larger SNA, LAX, BUR, LGB and surrounding airport competitive marketplace. It is difficult for ONT to offer the same variety of destination, non-stop, airline, and flight time options, cheaper prices, and experiential amenities like loyalty lounges, covered parking, shopping and dining options, and hours of operation that its competitors do. ONT passengers would appreciate more charging stations and ways to occupy their wait time before flights in addition to an early morning cup of coffee.

By capitalizing on ONT’s existing advantages, including current non-stop availability like Hawaii, Taipei, New York, Orlando, and more, and by leveraging the principles of behavioral economics, ONT can continue to offer excellent passenger experiences and grow their market share of the catchment region.

Our research studies show that passengers fall on a decision-making spectrum between valuing cost or convenience most highly when booking a flight. In most cases, except for those at the farthest end of the “cost value” spectrum for whom price is a non-negotiable first need, Corgan sees strong opportunity for catchment area business conversion and for continued existing passenger patronage.

Corgan’s multi-faceted signage program will support this continued passenger support and market growth according to passengers’ needs and behaviors related to familiarity with both flying in general and Ontario International Airport specifically. With attention to sense of place, establishing a welcoming ambiance of “having already arrived”, the signage program will focus on augmenting ONT’s experience at the first and last touch points of the airport, the new passenger wayfinding experience, and informational and directional support at key points of interest and decision points along the passenger journey.

We will explore this more in-depth via the personas, but at a high level, for passengers who are relatively familiar with flying and ONT, informational clarity (points of interest, amenities, services, etc....) and directional support will be most valuable at key decision points and for quick reference to confirm an existing path decision, supporting their need for a comfortable, convenient, and speedy journey. For those passengers who are newer to flying and/or to ONT, specific and detailed informational clarity and directional support will be provided clearly and frequently along the journey to decrease confusion, an over-reliance on airport staff (allowing them to focus their time on passengers who need and appreciate an extra human touch), and the tendency to simply follow other passengers to their destinations when unsure while navigating.

Using Matterport scans of ONT and time-simulations of passenger use cases while wayfinding, we have designed a program that offers something for each ONT persona, knowing that live ONT passengers may cycle fluidly through one or more persona modes according to their context on any specific trip. Our program is flexible enough to support these changing behaviors, meeting passengers where they are to enhance ONT’s existing brand and reputation for passenger experience excellence.

RESEARCH METHODS

At Corgan we practice a mixed methods approach to design research using both qualitative and quantitative data to glean insights into user needs and behavior which inform our design solutions.

Qualitative research methods refer to the collection, interpretation, and analysis of data that is non-numerical, such as user interviews and behavioral observations. This data is especially valuable at revealing the nuanced reasoning behind quantitative outcomes.

Quantitative research methods refer to data that is numerical in nature: things like time, completion rates, Likert scales, and other measurable results. This kind of data is useful for creating success benchmarks and KPI metrics to compare against for improvement such as ONT's ASQ data.

For this project's purposes we conducted both primary and secondary research studies. We conducted user interviews through our confidential, opt-in platform, UserTesting.com.

Primary

Qualitative

- 7 user interviews with Inland Empire locals to understand sense of place perceptions
- 10 user interviews with catchment area passengers
- 10 user interviews with ONT's self-affirmed O&D passengers
 - All have traveled through ONT at least three times in the past two years and have traveled through at least one competitor.

- 20 user interviews with ONT's self-affirmed Visiting passengers
 - 10 who typically fly into ONT
 - 10 who typically fly into a competitor
 - All have traveled through ONT at least three times in the past two years and have traveled through at least one competitor.
- Pre-survey
 - Comparison between stakeholder and ONT passenger perspectives on the airport's competitive advantages and opportunities for improvement (early findings were validated by later user interviews and are ready for scale comparison via email subscriber survey analysis).
- Social Media Listening
 - Review of ONT's twitter interactions and thematic analysis of their most recent 100 Google reviews to understand which aspects of the passenger experience are most salient to passengers online.

Quantitative

- ASQ data review from Q4 in 2019 and 2020, results compared with Google review thematic analysis results
- Survey creation in MS Forms and shared with Hiltachk and ONT to be used to validate qualitative findings in terms of scale.

Secondary

- Research into cognitive science in terms of brain image-processing and stress/performance correlations
- Research into how behavioral economics can be leveraged to both support passengers' goals and increase ONT market share.



RESEARCH FINDINGS

As discussed in the executive summary, it is very clear that ONT's competitive advantage lies in its positive passenger experience: quick, easy, simple, beautiful, friendly, close, and convenient.

Passengers described these positives in their interviews highlighting:

"Ontario offers a very smooth experience...It's fast and efficient. Staff are pleasant; they really seem to enjoy their jobs."

– O&D pax

"I can't think of anything negative about Ontario. It's a small airport, but it does what a small airport needs to do. I don't expect...ONT to have all these crazy lounges or anything like that...or all of these fancy amenities that larger airports do...it does what it does well"

– O&D pax

"This is awesome. We don't have to fly out of LAX...it's clean, it's nice, it's modern."

– O&D pax

"I like flying into ONT for the scenery...the hills are beautiful...and for how clean it is...it's not a hard airport to navigate."

– Visiting pax

"When I fly in, it's easy to get to my destination...it's not like LAX which is very chaotic...it's not hard to get a taxi."

– Visiting pax

"I often choose ONT because of its cleanliness...it's more relaxed [not as packed as LAX] ...Easy and quiet."

–Visiting pax

"It's very clean...the staff is friendly...and it's also nice to see the surrounding mountains and local artwork scattered throughout...pleasant to see and very appealing."

– Catchment pax

"[ONT is] smaller; so, it's very quick to get in and out of. Security is always really fast...it definitely is an easier place to fly out of for where I live instead of having to go into LA. I would prefer to park at ONT...It's much smaller and quicker."

– Catchment pax

"It's so easy to drive straight up to the terminal area...so easy to pick people up... So easy driving into and out of. I really would prefer to fly into and out of ONT. It's just the destination [options] that hold me back."

– Catchment pax

At the same time, passengers from O&D, visiting, and catchment user groups agree that ONT isn't as competitive when it comes to flight prices, destination options, non-stop flights, flight time availability, loyalty program and lounge options, mass transit availability, amenities, and shopping and dining options.

In interviews passengers noted these opportunity spaces saying:

"The downside is the amount of flights that go in through Ontario...there's not a lot of selection."

– Visiting pax

"The main problem with Ontario is the lack of public transportation...you have to have your family take you or take one of those blue buses."

– Visiting pax

"[ONT could improve my experience by offering] more mass transit availability and more disability access...more flight traffic...it's very limited sometimes, especially coming from the east coast."

– Visiting pax

"A lot of the restaurants were closed, but there were people there. I was kind of bummed out that there weren't more restaurants open...ok when is the next time I'm going to eat.?"

– O&D pax

"My only challenge is finding non-stop trips outside of California...I would definitely find that at LAX, and it would be cheaper."

– O&D pax

"Since it's not as big as LAX it doesn't give you as many options throughout the day...especially direct flights, I had to go to LAX...especially around certain flights (Austin)."

– O&D pax

"I'm actually closer to Ontario than LA...LAX is a bit further but...I don't get good deals [at ONT]. The price is too high for flights, and usually I can't find the ones that I'm looking for."

– Catchment pax

"I haven't found cheap enough flights [at ONT]. It's drivable.... mainly comes down to price of tickets."

– Catchment pax

"I would typically prefer to go to ONT if they had more flight options and if the prices were less than LAX...typically [LAX is cheaper and has more flight availability]."

– Catchment pax

When asked what, if anything, ONT could do to improve their passenger experience, user groups highlighted experiential requests in addition to more destination options, flight times, and non-stop flights. They value ONT’s commitment to cleanliness and would like more comfortable support in the airport via lounges, shopping and dining hour extensions, and ways to stay engaged while waiting for their flight:

"More expansion...maybe get additional airlines to fly in there; so, I could have additional options in terms of routes."

– O&D pax

"[Thinking about LAX] I kind of like the pre-email they send about where things are and what you'll need to be on the lookout for...I don't know if [ONT sends] those."

– O&D pax

"If they had Wi-Fi that'd be great...and lots of charging places...cause some of us don't come with a full phone."

– O&D pax

"I don't remember if they have free Wi-Fi, but I love free Wi-Fi. I would love it if Ontario could kind of model itself off of Portland's airport. Not necessarily like a full-time piano player, but the food at Portland is great...Even like the little things...at TSA there are cute little benches for the children, as a mother, that's really great."

– O&D pax

"A little bit more food options in the airport...and maybe have a lot of the places [open early]. A lot of them are not open...there's people at the airport who will buy food and go shopping. It kind of sucks when they're not open."

– O&D pax

"Maybe have a shuttle to that metro line that's gonna run out to Pasadena or to the metro train that runs from San Bernardino to Los Angeles." – Visiting pax

"Maintain cleanliness standards...that's very important to me...just continuing to keep the airport clean because if that falters [so will the image.]"

– Visiting pax

"Right now, the most important thing has to do with cleaning procedures and making sure everyone feels safe."

– Visiting pax

These existing advantage and opportunity findings were validated quantitatively through review of ONT’s ASQ data from Q4 of 2019 and 2020 and through a thematic analysis of ONT’s most recent 100 Google reviews.

The Google reviews revealed 41 unique themes surrounding the passenger experience, but nine emerged as the most salient and frequently mentioned with ten mentions or more:

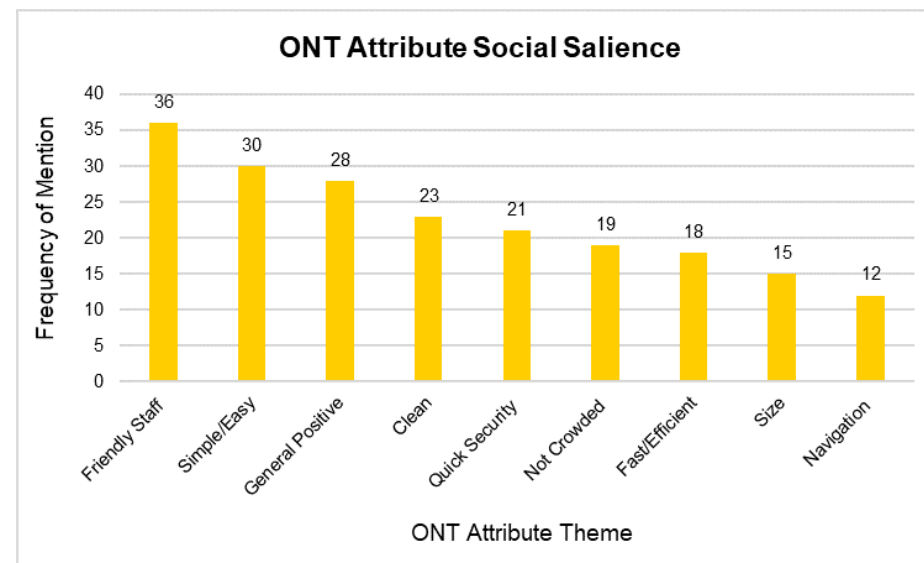

Among these nine key positive review themes, ONT’s friendly staff were by far the most frequently mentioned. ONT’s staff is a huge asset to their passenger experience competitive advantage.

These themes were also validated when reviewing ONT’s ASQ data from Q4 of 2019 and 2020:

2019 experience successes:

- Ease of Wayfinding (4.39)
- Efficiency of Check-in-Staff (4.37)
- Courtesy/Helpfulness, Check-in-Staff & wait time at Passport/ID Inspection (4.33)

2020 experience successes:

- Efficiency, Check-in-Staff (4.56)
- Courtesy/Helpfulness, Check-in-Staff (4.54)
- Wait time, Check-in/ Queue & Ease of Wayfinding (4.52)

The areas for improvement also validated our qualitative findings showing that passenger perceptions of the “value for money” regarding parking, restaurant and eating, and shopping facilities scored the lowest in both 2019 and 2020.

Leveraging the principles of behavioral economics like the zero-price effect discussed in the secondary research section of this report could help to improve passenger perceptions.

WAYFINDING TAKEAWAYS

We analyzed wayfinding behaviors and needs across O&D and Visiting passenger user groups and found that in general, passengers are happy with the existing wayfinding system. They think it's much easier than the systems found at most other international airports, but there is some nuance.

Although existing signage is thought of as largely sufficient and successful, there is room for clarification especially regarding locating terminals and their corresponding airlines when navigating parking options, and finding ride-share, taxi, rental car, and transit services. There is also room for an improved passenger experience regarding informational signage and maps, clarifying where visiting passengers can grab food or shopping sundries or find additional bathrooms and mother's rooms after a long flight. Passengers sometimes need extra support.

Our research shows opportunities for improvement via the new passenger wayfinding experience and at the first and last points of contact specifically, in addition to all key decision points along the passenger journey. A strong sense of place will support these needs, offering an inviting welcome to the region for visiting passengers, and a pleasant feeling of home for O&D passengers.

All user groups agree that ONT's staff is friendly and supportive, but there is a greater than necessary wayfinding burden currently placed on the staff with the existing signage program. With a new, tailored signage system that is able to stand alone in terms of directional and informational support, ONT staff will be able to focus their time more efficiently and effectively on the passengers who prefer and/or need that extra human touch more than others.

While most pax report using low-tech overhead signs most frequently, maps, displays, and technological support are still appreciated. In the absence of successful wayfinding elements throughout the journey, ONT passengers turn to human support via Customer Service or the passengers around them, following those who were on their same flight.

The positives of the existing system are very apparent. When a mix of 30 O&D and visiting passengers were asked how easy or difficult it is to navigate ONT on a scale from 1-5, with 1 being very difficult and 5 being very easy, the vast majority, 67%, chose 5- very easy sharing comments like:

"Very easy because it's such a small airport...the signs are very direct and they're easy to navigate."

– Visiting pax

"Very easy...quick...so much a better experience than other airports I've been to."

– Visiting pax

"You follow the signs; there's never any issues."

– Visiting pax

"Compared to LAX, [it's so much easier to fly in and out]; there are fewer gates...if you're running a bit late, [it's] easier to get there quickly...everyone is friendly." – Visiting pax

"The parking is very easy, very small lots."

– O&D pax

"Extremely easy airport to get around...signage is clear."

– O&D pax

"The signs make it really easy to find stuff and make it easy for anyone to navigate."

– O&D pax

"I think Ontario is very easy; it's as simple as you can get."

– O&D pax

But the opportunities for improvement regarding informational clarity and the new passenger wayfinding experience became clear when we next asked how easy or difficult it would be for someone unfamiliar with or new to ONT to navigate on a scale from 1-5, with 1 being very difficult and 5 being very easy. In this case, only 37% chose 5 – very easy, and 27% chose 3 – neutral. Passengers explained their choices commenting:

"If you're someone who doesn't fly out a lot, it would be somewhat difficult [to navigate as a new passenger]."

– Visiting Pax

"[When I was new] I do remember asking lots of people where certain things were located...despite its small size, someone can easily get lost along the way if it's your first time there."

– O&D pax

"[Wayfinding is] a little bit difficult... I also think there could be more Spanish on the signage; I'm a little bit sensitive to that because of my background and the number of Spanish speakers and travelers in that part of California."

– O&D Pax

"First time traveling to an airport? I'm going to say it's very difficult, and that's just from the sheer size of it. It's easy to get turned around and lost."

– Visiting Pax

Understandably there is a bit of a learning curve associated with the existing program. Despite the overall positive perception, passengers often qualified ONT's ease of navigation:

"Once you've been there a few times already, you know how to get around."

– Visiting Pax

"You really have to be comfortable with looking up and seeing where the signs are, but for the most part, it's not difficult."

– Visiting pax

"Maybe the first time I did it, it was a little confusing to find the rental car parking lot, but someone pointed me in the right direction."

– Visiting pax

"Always a little bit of a learning curve when you go to a new airport...their own peculiarities...probably not as easy as [when you're familiar]."

– O&D pax

Passengers also acknowledged that when there is higher cognitive load, such as when the airport is more crowded, the wayfinding is more challenging at ONT:

"It's usually not congested...that always makes things easier if there's less people there."

– O&D pax

"You do get a lot of people every now and then which complicates things."

– O&D pax

Interviews with O&D and visiting passenger user groups revealed that wayfinding support needs largely correlate with a passenger's level of familiarity with flying in general and ONT specifically.

Those who are familiar with flying and/or ONT require less overall support and tend to need directions and informational clarity only at key decision points, or just as a refresher if they have been away for a while:

"I've been to Ontario enough times; I don't need to look at the signs."

–Visiting pax

"Because I've been using Ontario pretty much all my life, I pretty much know where to go...Once you pass security, those are...the signs that I use...if I use them."

– Visiting pax

"I know exactly where to go because I always fly out of [ONT]...other than to look real quick at the signs to make sure I'm going the right way...it's very easy."

– O&D pax

"It wasn't hard to get to where I needed, mainly because I had already been doing this for quite some time...it had been a long time since I had done so; so, I do need a refresher."

– O&D pax

Conversely, those who are new to the airport or less familiar with flying in general require frequent specific directional and informational support throughout their passenger journey.

It's important to note that "inattentive blindness" can occur when a passenger's context needs make certain aspects of the wayfinding program less important, such that they sometimes cannot remember signs that don't relate to them or even how they navigated at all if another member of their party lead the way:

"I don't remember [how I navigated]. I guess my husband."

– O&D pax

"I don't think there are maps; I don't know...I always use signs."

– Visiting pax

A passenger who is very familiar with the airport in one specific context, such as following their usual route for work travel, may need the same level of wayfinding support as an unfamiliar first-time passenger if their context needs change, such as when traveling with kids on vacation instead of following their usual work routine. Our program is designed to be flexible enough to support changing levels of familiarity and needs accordingly.

PERSONAS

With these competitive advantages, opportunity spaces, needs, and goals identified and validated through qualitative and quantitative methods, we created four personas to represent ONT’s users and how the airport can best support their unique passenger experiences in accordance with their placement on the cost/convenience value spectrum and their level of familiarity with the airport and flying:

- Victor, the “sometimes shopper” is a dad from the catchment region, falls in the middle of the cost/convenience spectrum and on the higher end of familiarity having occasionally traveled through ONT before.
- Carla, the “convenience shopper” is an anxious traveler who lives close to ONT and values convenience at the highest level. She is less familiar with traveling and worries about missing her flight.
- Mika, the “unfamiliar visitor” values cost more highly than convenience in most cases and finds himself at ONT by accident when his connection gets re-routed. He is unfamiliar with ONT but is relatively familiar with traveling in general.
- June, the “familiar visitor” grew up in the area and travels home to visit family and friends. While cost is important to her, the convenience of being close to her final destination is worth paying more to fly into ONT. She is very familiar with the airport.

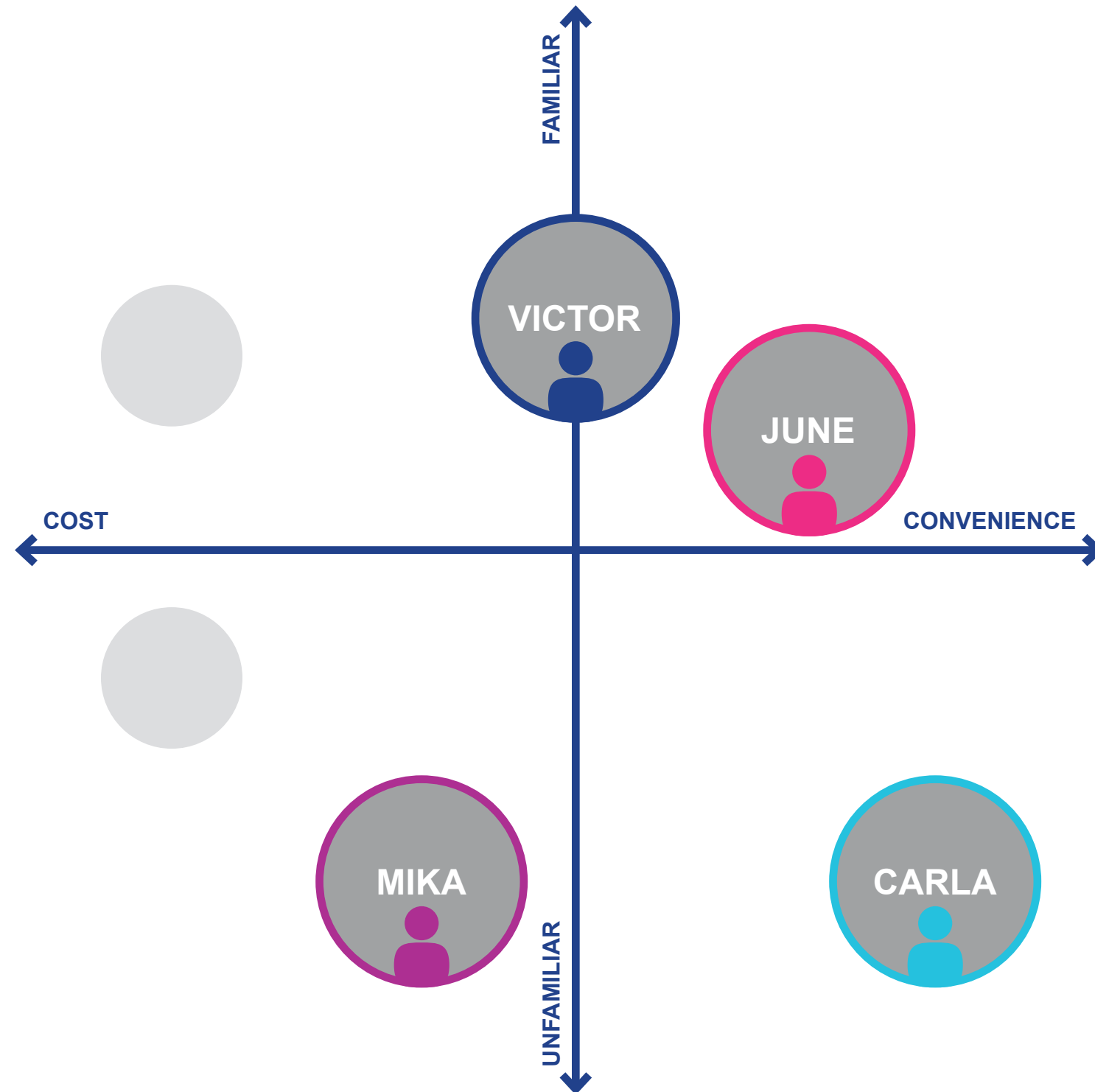



Victor

A Sometimes Shopper

Victor is a dad living in the Inland Empire with his sons. He travels 3x/year to attend CE conferences for his license as a family doctor. Saving to open his own practice, Victor keeps a strict budget and generally flies through LAX to get lower fares. But he really wants to spend more time with his family, and avoid the chaos of traffic with kids. He has I.E. pride and loves that ONT is a prominent part of the community. He prefers the simple, easy family experience at ONT.

Victor values cheap flights and non-stop destination options, but he is also willing to pay for convenience when possible and needed. Other catchment area passengers like Victor are great candidates for marketing targeted at ONT's existing non-stop locations like Orlando and Hawaii.

Passengers like Victor who are somewhat familiar with the airport need wayfinding support at key decision points like right after security and when choosing parking options. They also need informational clarity regarding points of interest to their context, such as family bathrooms, kid-friendly dining options, ride-share locations, the ONT Paw Squad etc.

Locals often alternate between Sometimes Shoppers and Convenience Shoppers situationally:

- The top decision makers for the catchment area are flight price, destination options, and flight time availability, but many like Victor are willing to devalue price for convenience, speed, and ease when possible and needed.
- Capitalize on the preferred non-stop options ONT already has such as direct flights to Hawaii

Wayfinding Needs:

- Quick reference support at key decision points for passengers who are somewhat familiar with ONT.
- Informational clarity on where to find relevant points of interest to that passenger's context: Ex: family bathroom, ONT Paw Squad, kid-friendly dining options, rental car



I would typically prefer to go to ONT if they had more flight options and if the prices were less than LAX... [LAX is usually cheaper and has more flight availability].

Need for Informational Signage:



Need for Directional Signage:





Carla

A Convenience Shopper

Carla lives very close to ONT, but she doesn't travel often and worries about getting lost and missing her flight, even in smaller airports. She appreciates that ONT is close, quick, and easy. To avoid making mistakes and parking near the wrong terminal, she takes cheap Ubers. While ONT doesn't have tons of amenities to distract her from her anxiety, it's rarely crowded and the friendly staff always put her at ease.

Carla values convenience, speed, and ease in her ONT journey. The small size, quick security check, and friendly customer service help her travel more comfortably. Experientially, she would appreciate more amenities, charging stations, food and dining options, and entertainment, but the short commute time from her house is most valuable to her.

Unlike Carla's neighbors who are very familiar with the airport and hardly check wayfinding or informational signs at all, passengers like Carla need the highest level of informational clarity and directional wayfinding support at frequent points along her journey. She appreciates the personal touch of talking to ONT customer service representatives.

Quick commute times and security checks in addition to parking availability are key deciding factors for Convenience Shoppers like Carla who live close to ONT.



"I'm really more of an old school person... I would rather just ask the people that are working there [for directions and help] to get where I need to go."

They love the size, the fact that it's not chaotic or busy, and the friendly staff, but would benefit from more charging stations, and dining and shopping options for early birds.

Wayfinding Needs:

- Unfamiliar passengers like Carla need clear, frequent directional and informational touch points to find the right parking lot and navigate to their gate with desired clarity about available services, shopping, dining, etc...
- In the absence of clear signage, unfamiliar passengers just follow the people around them or ask for help.
- Familiar Convenience Shoppers by contrast tend to know their favorite routes by heart. They hardly check wayfinding signage as they learn where they're going after a few times, but they value the ability to quickly reference directional signage at key decision points.

Need for Informational Signage:



Need for Directional Signage:





Mika

An Unfamiliar Visitor

Mika typically flies into LAX when he vacations in California for the Summer. After a frustrating missed connection brings him to ONT instead, he's pleasantly surprised by how close he is to L.A.. Easy access to dining and mass transit options are important to him when he lands at a new airport, especially if he is commuting after, but quick security checks and cleanliness are especially key.

Mika generally values cost more than convenience, but ONT's cleanliness, proximity to his destination in LA, and quick security check have the potential to convert him.

As a comfortable traveler, but also someone unfamiliar with ONT, he needs a nice welcome that is atmospheric in terms of sense of place, but also functional and clear in terms of his immediate needs like the restroom, shopping and dining options after his flight, baggage claim, and directions to transportation options. He is especially interested in mass transit availability.

While price and destination options are most important to visitors, ONT's quick commute times and cleanliness protocols are also key deciding experience factors for visitors.

Wayfinding Needs:

- Unfamiliar visitors like Mika will strongly benefit from the first and last touch points of the sense of place and wayfinding strategy; they need access to practical information along with the pleasant feeling of "having arrived" after a long flight.
- Good opportunity for a sense of place introduction via information about local attractions, dining options, hotels that offer free shuttles
- Visitors want informational transparency regarding how far they are from points of interest like hotels, restaurants, transportation, and their final destination



"ONT is in the location where I want to be in the SoCal area, the experience is...a pleasant one...[keep] maintaining cleanliness protocols. **Right now that's the most important thing, to feel safe.**"

Need for Informational Signage:



Need for Directional Signage:





June

A Familiar Visitor

June grew up in the area and comes back every few years to visit family and friends. She has flown through ONT many times and loves how easy it is and that ONT offers a short commute home. When she's been away for a while, June needs quick refreshers to help her find her way around and to her rental car even though she would prefer to take the San Bernardino Metro if access were faster. She's often hungry and tired after flying and wishes she could grab a burger on her way. She always feels at home when she sees the mountains.

June values convenience over cost when flying home to the Inland Empire. She is a familiar visitor who knows the airport almost well enough to forgo wayfinding and informational support completely, but since she visits infrequently, she values reminders at key decision points. She needs clarity about the transportation options available to her when her family isn't picking her up, and she would appreciate longer dining hours in addition to more flight availability.

Even though ONT flight options are occasionally limited, she values the short commute time to her final destination and the quick, comfortable experience she expects from ONT. She will really appreciate the sense of place welcome she receives after touching down in Ontario.

Wayfinding Needs:

- Familiar visiting passengers like June need less signage support; quick refreshers to key points of interest are helpful



“It wasn't hard to get to where I needed... but it had been a long time since I had done so; so I did need a refresher.”

Need for Informational Signage:



Need for Directional Signage:



SECONDARY RESEARCH: LEVERAGING THE PRINCIPLES OF COGNITIVE SCIENCE AND BEHAVIORAL ECONOMICS

Our primary research studies helped us to fully empathize with ONT’s passenger user groups and understand their needs from their own perspectives. But secondary research into cognitive science and human behavior allows us to design solutions that best support passenger needs they may not be aware of in terms of processing capabilities, attentional salience, purchasing behavior, and performance variables.

It’s a truism of all signage and wayfinding programs that there is no such thing as a fail-safe system; humans will always make mistakes. To improve signage usability and decrease the risk of human error in the airport, we design in accordance with how the human brain works.

Mary Potter, an MIT professor of brain and cognitive sciences, validated the importance of visual aids in her research proving that the brain can process images in just 13 milliseconds.¹ With such quick processing, imagery can help users understand content quickly. Potter notes that “The job of the eyes is not only to get the information into the brain, but to allow the brain to think about it rapidly enough to know what you should look at next.”² Her research suggests that strategic signage support and iconography can support efficient airport navigation and help passengers understand where to look next for informational and directional support.

Although the brain’s perception capability is impressive, it is still subject to performance-reducing factors such as stress and cognitive load (such as traveling with children, running into traffic on the way to the airport, needing to use the restroom or feeling

¹ Potter, Mary C., Brad Wyble, Carl Erick Hagmann, and Emily S. Mccourt. “Detecting Meaning in RSVP at 13 Ms per Picture.” *Attention, Perception, & Psychophysics* 76, no. 2 (2013): 270–79. <https://doi.org/10.3758/s13414-013-0605-z>.

² Trafton, Anne. “In the Blink of an Eye.” *MIT News | Massachusetts Institute of Technology*, January 16, 2014. <https://news.mit.edu/2014/in-the-blink-of-an-eye-0116>.

hungry, etc...). Small amounts of stress can make passengers more aware of the task at hand and improve their performance, but too much stress will lower their performance, thus increasing the likelihood of errors. This is explained by the Yerkes-Dodson Law, visualized by the following diagram, which showcases the relationship between stress arousal and performance.

The Yerkes-Dodson Law

How anxiety affects performance.

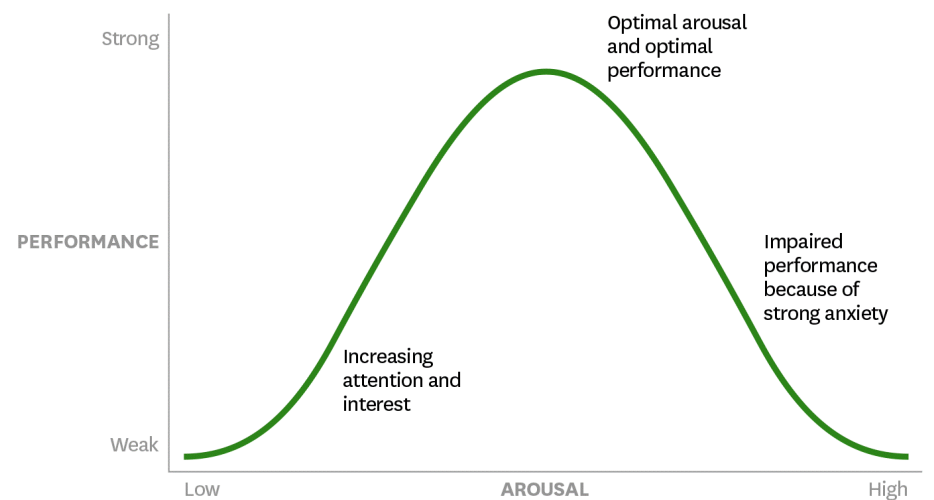

SOURCE ROBERT M. YERKES AND JOHN D. DODSON

© HBR.ORG

Knowing that airports are environments that can create stress and anxiety in passengers, a strong wayfinding program is needed to help off-set passengers’ potential for decreased wayfinding performance on stressful days, even for familiar passengers who typically navigate well.

One way to do this is to promote recognition rather than recall in our designs. Retrieving memories requires more mental resources when recalling information without context, than it does when recognizing information from context clues like iconography and consistent messaging.

Additionally, the brain remembers concrete words more easily than abstract words.³ A combination of salient visuals and concrete terminology in the signage program can help passengers recognize poignant context clues as they navigate the airport (example: signs for the mother’s room or family bathroom, signs for rental cars and baggage claim, etc...).

It’s also important to acknowledge the occurrence of “inattentional blindness,” a term created by Arian Mack, PhD and Irvin Rock, PhD to describe the phenomenon revealed in their research where users could see but not perceive certain stimuli when their attention was focused elsewhere.⁴

In *What Brain Research Says About Paying Attention*, Researchers Sylwester and Cho describe how due to humans’ limited capacity for attention, “when we consciously seek... specific information, our attentional system primes itself in anticipation. It increases the response levels of the networks that process that information, and it inhibits other networks.”⁵

Because passengers’ current goals and prior experience with airports will impact their attention in the airport and which aspects of our signage program are most salient to them in that moment, our sign program must expect and support lapses in attention and provide multiple touch-points for focused informational clarity that will facilitate goals like findings restrooms, dining options, baggage claim, etc....

³ Kendra Cherry, “Inattentional Blindness Can Cause You to Miss Things in Front of You,” *Verywell Mind*, May 4, 2020, <https://www.verywellmind.com/what-is-inattentional-blindness-2795020#citation-4>.

⁴ Robert Sylwester and Joo-Yun Cho, “What Brain Research Says About Paying Attention,” *Educational Leadership* 50, no. 4 (December 1992): pp. 71-75, <https://doi.org/http://www.ascd.org/publications/educational-leadership/dec92/vol50/num04/What-Brain-Research-Says-About-Paying-Attention.aspx>.

⁵ “Principles of (Behavioral) Economics,” *American Economic Review* (American Economic Association, January 1, 1970), <https://dash.harvard.edu/handle/1/30805504>.

A successful wayfinding program design can help passengers achieve their goals to have quick, easy, convenient, positive experiences at ONT by supporting their cognitive processing and attentional needs, but ONT can also use the principles of behavioral economics to increase their market share from an experiential level. As discussed in the executive summary, our interviews revealed that ONT passengers fall on a decision-making spectrum between valuing cost and valuing convenience:

"Flight price is very important...depending on which airport I fly out of; I am able to save \$200-300 dollars...the distance would be worth it to drive an hour to save a few hundred dollars."

– Catchment pax

"Convenience is the most important thing...if [ONT] can provide those options and can give me that comfort; I would be very happy to choose [ONT]."

– Catchment pax

ONT can use the behavioral economics principles of **default bias, loss aversion, the zero-price effect, and the tendency to optimize situations to minimize regret** to increase market share by supporting passengers who are willing to pay for convenience and who want to avoid missing their flight and losing time in traffic. It's important to note that principles of behavioral economics describe human behavior and don't predict it.

Default Bias tells us that people tend to stick with an option or purchase routine because it requires less cognitive load than making a different choice. By providing a successful, convenient, and overall positive passenger experience, ONT passengers will have a good reason to continue making it their default airport, as many O&D passengers already do:

"I pretty much always pick Ontario due to the fact that I live ten minutes away from the airport...sometimes we just pay more money to fly out of Ontario [than LAX]...we live so close we can just get dropped off or take an uber that's pretty cheap."

– O&D pax

Loss aversion research shows that people feel the pain of losing a resource approximately two times more strongly than they feel the joy of gaining the same amount of that resource. While ONT is not as likely to be competitive in terms of cheap fares (financial resources), it is much more competitive in terms of speed and efficiency (time as a resource). ONT can lean in to helping passengers who want to avoid losing time in their messaging and outreach:

"I just care about getting there on time and getting to where I need to get on-time. That's what matters most to me...if they can respect the time-schedule and if the plane leaves at the time indicated, I will find that satisfying. [ONT does things] in a timely manner."

– O&D pax

Zero-Price Effect, this effect describes the tendency for people to perceive a higher intrinsic value of items when the cost is reduced to 0. People like free things. Experientially, ONT can increase passengers' perception of the value they are getting by leveraging opportunities to offer freebies. The ASQ data revealed pain points in both 2019 and 2020 in terms of the value for money passengers perceived regarding parking, shopping, and dining facilities. While ONT may not be able to add more loyalty program lounges, dining and shopping options, or covered parking, they could look at offering free coupons for up to \$5 at vendors, sponsoring free food trucks from local favorites for the day (coffee, ice cream, etc...), offering the first 30 minutes of daily parking for free and/or the first day of long-term parking for free, etc...or similar budget-appropriate offerings to improve the perceived value of existing amenities.

"[ONT could improve my experience by] building lounges where people can actually take advantage of their credit card company like Chase Sapphire Preferred. [Lounges give] give you opportunities to take advantage of these loyalty programs."

–O&D pax

"[ONT could improve my experience by] offering free amenities."

– Visiting pax

Optimization to minimize regret, research shows that people will optimize their situations to minimize the likelihood of the worst possible outcome when decision-making. They will choose the option that minimizes regret even if it's not the best choice. For passengers who value cost most highly on the cost/convenience spectrum, ONT is not as likely to be their first choice. But for those who value convenience and speed most highly, they will be great candidates for ONT market conversion because they are likely to choose to pay more to minimize the chance of regret of an uncomfortable experience that might ultimately cost more with traffic and parking or a missed flight.

"[Choosing to fly out of LAX] was cheaper, but it cost me more mentally and physically."

– Catchment pax

"I've probably spent over \$100 on an Uber or Lyft or renting a car; it's just an extra hassle [to fly into LAX and pay to drive closer to ONT.]"

– Catchment pax

CONCLUSION

ONT is well-positioned to grow their market share of the catchment region by continuing to invest in their already strong passenger experience advantages. With tailored experiential and wayfinding design solutions supported by a new signage program with a strong sense of place, passengers who value convenience, speed, and ease more highly than cost will find their air travel needs and goals well-met by ONT.

Sense of Place Analysis

Many factors will shape the ultimate design of the Ontario International Airport wayfinding system. An evaluation of the surrounding region and its influence on the terminal ambiance and wayfinding strategies was undertaken. The results of this informed the design team's recommendations for how to create a 'sense of place' that is desired in the terminal environment.

KEY TAKEAWAYS

Geographically, the visioning result shows that participants primarily view "home" as the surrounding region. From the Mountains to the desert and suburb, the Ontario identity is not limited to its city limits.

It is important to heighten ONT identity through this wayfinding exercise. ONT situates in a region that can range from Southern Californian to suburbs of LA. A well-established identity will differentiate ONT from surrounding competitors and its well-known neighbors.

Result shows that you celebrate the simplicity of lifestyle. Resonating from ONT's passenger demographics through your own concerns of what growth will do to you. The simplicity and clarity of who you are needs to shine through both interior and wayfinding experience of your terminal.

The ONT brand is important to establishing the airport's identity. The airport has come a long way in its history. While your wayfinding package won't be limited to this, the ultimate proposal must acknowledge and celebrate your current brand.

It all comes back to people. The Airport, much like a favorite local restaurant, fits and attracts people based on the human considerations – ease and simplicity, staff and experience, and human centric design needs to remain a central focus.



VISIONING SESSIONS

Through a series of virtual polls, guided conversation, and multiple question and answer sessions, the Corgan Design team was able to establish a deeper understanding of Ontario’s sense of place. The polling audience included stakeholders, airport employees, and city employees; a well-rounded group of participants that knows the airport and will experience the design outcome, as well as a variety of individuals intimately familiar with the city. Categorically, it allowed for an analysis of the geography, the extents of what the group viewed as their ‘home’, the culture, financial drivers, and Ontario’s future. Defining these categories allowed for the design team to apply the right amount of sense of place into the creation of the terminal wayfinding pieces and help tell the story of Ontario through each design option.

The following breaks down the individual questions asked of the polling group, the intent behind asking the question and the resulting information from each question.

Q1 - GEOGRAPHICAL ASSOCIATION: Ontario best sees itself as a representation of ...

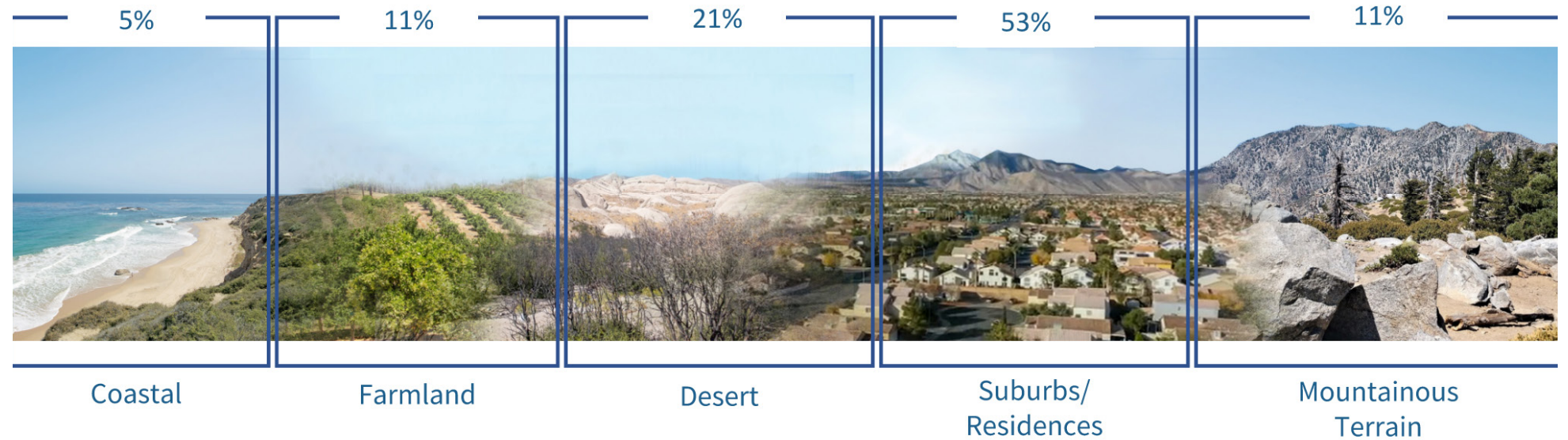

The question intended to pull from the polling audience a greater understanding of how Ontario views itself, beyond just what lives in the city lines on the map. The resulting answer allowed us to understand the comprehensive nature of how Ontario sees themselves, and while it largely exists in the suburbs within city limits, it also extends to incorporate those geographic elements even beyond the extents of the inland empire. Conversation that followed suggested that occasionally nostalgia and memories of traveling through Ontario to get to some of the outlying geography affected their answer.

Q2 - When I reference my home to visitors and non-locals, I'm likely to reference the ____.

The question intended to develop an understanding of how those living in Ontario represent their home. The resulting answer further confirmed the result of the previous question, suggesting that the true border of Ontario is of a lesser significance than the overall region and it’s association with Southern California. This representation further confirms Ontario’s reputation as a gateway to all of Southern California, and the airport as an easy means to get there.

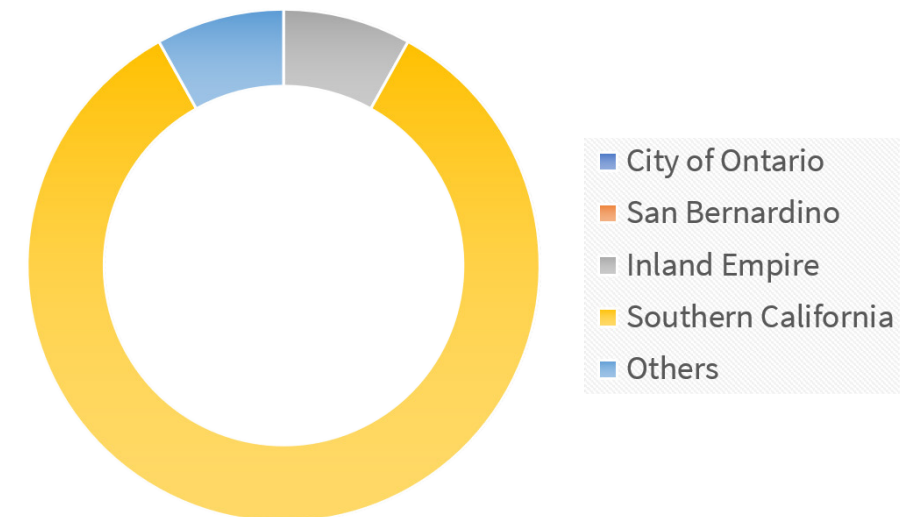

Q3 - Ranking Exercise – In your opinion, those traveling through the Ontario airport are most interested in...

Visiting family and friends who live in Ontario

Industry Convention/ Business

Heading to the Coast / Beaches / LA / Route 66

Hiking and the Mountains

Tourists specifically interested in Ontario proper

Others

This question asks the polling audience to express their understanding, from observation, conversation, and their deeper knowledge of working for the airport, as to why people travel to ONT. This result does not match the other answers as ONT operating as a tourism gateway, but rather indicates the tight knit community and family aspects that draw people to Ontario.

Q4/5 - Please select up to 3 images that resonate with you regarding Ontario and its surrounding regions...

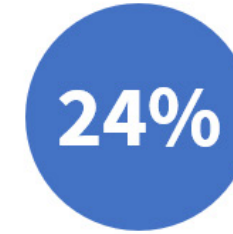
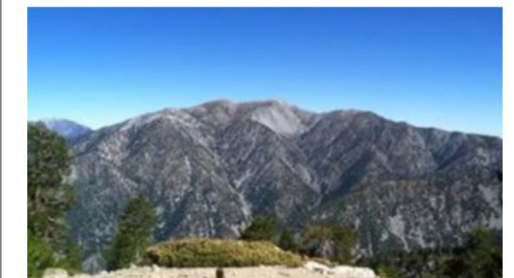
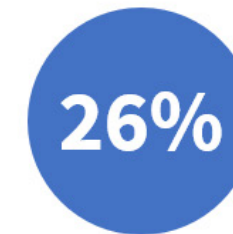

This question is intended to have the polling audience quickly determine areas that resonate with them when they think of their home. The original 12 images highlight geographical influences, as well as architecture, and urban development. The resulting answers help the design team understand if the polling audience feels the same when hit with phrases and keywords versus when presented with graphic representation of these same areas. In this case, the mountains had a stronger presence than the suburban surrounding.

Q6 - Today the City of Ontario's economy is fueled by...



Q7 - In 15 years, the City of Ontario's economy will be fueled by...



Q8 - Please rank the Economic Drivers according to their significance in the area.



Questions 6,7, and 8 were purposefully grouped to analyze perceived Economic Drivers from the group. While this information could be factually pulled for the area, it was more pertinent to discern what the group's perception of the economic drivers was and their visibility. A great deal of conversation was had around the topic, largely surmising that while growth can be good, it brought fear of disrupting the simplicity of lifestyle and slower pace that is treasured in Ontario. Questions 9 intended to determine the audience that ONT is most interested in reaching with this wayfinding package. The responses those 'who live in Ontario', and those they were 'wishing to draw to Ontario' complimented the simplicity of lifestyle as well as the simple and efficient experience that was cherished most by users surveyed (conveyed further in the Passenger Behavior Analysis).

Q9 - Ranking Exercise - Audience Alignment – The airport is primarily trying to reach out to...

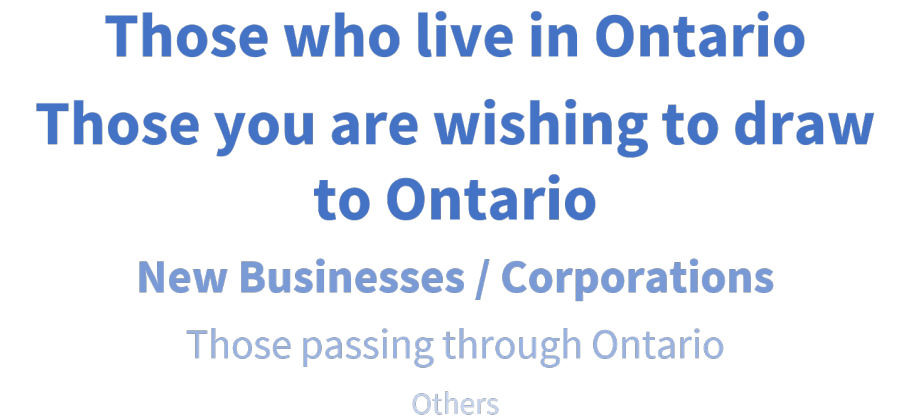

Q13 - Click Quintessential Ontario...

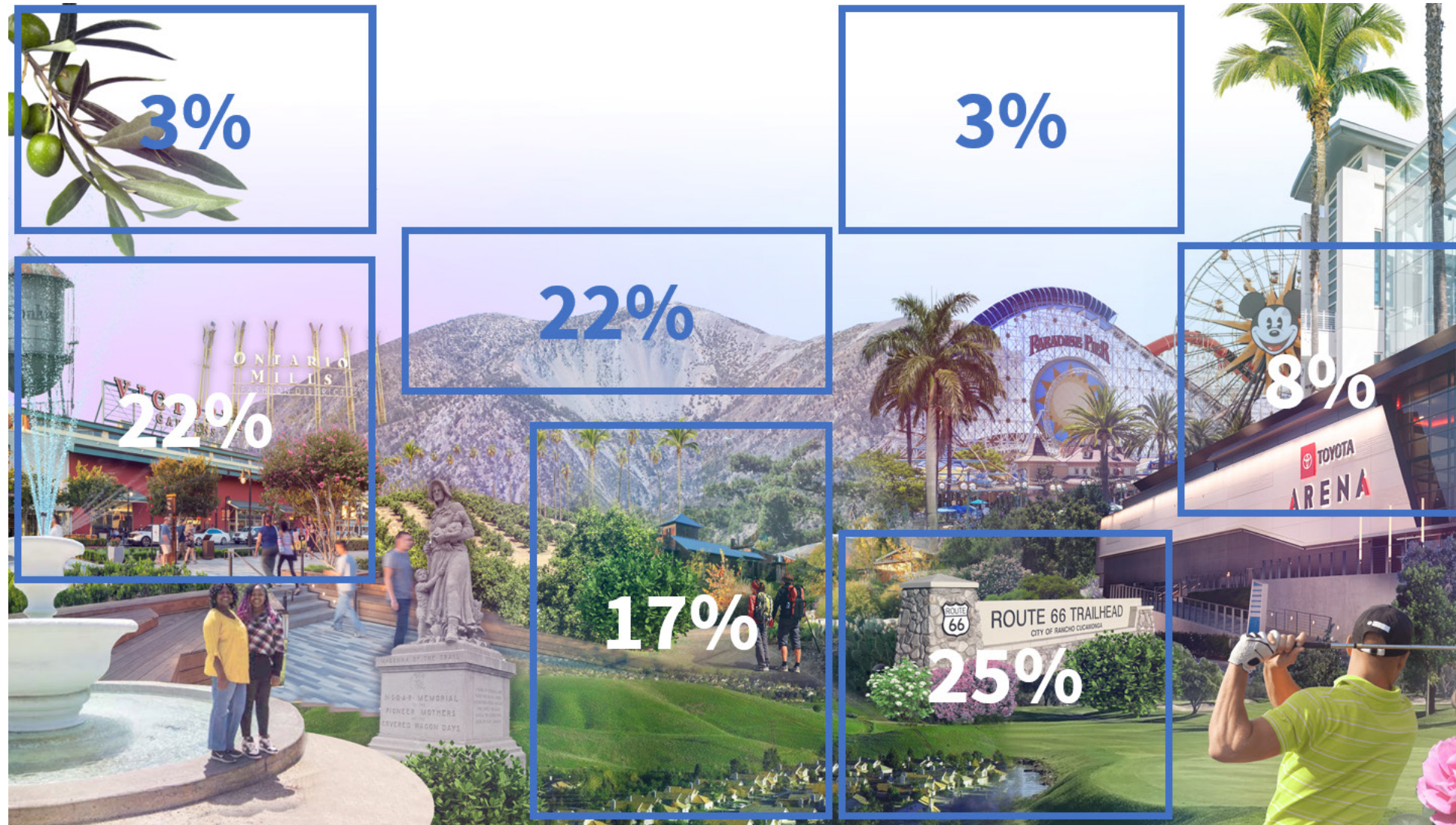

Q14 - Please rank the following descriptions of Ontario:

Suburbia
Middle of it all
 Historic
 New Model Colony
 Community

The question pulled major descriptors from travel guides, city websites, and other city specific documents with the intent being to capture a more accurate description of how Ontario feels from the people who live there. The results related to the domestic nature of the city, with highlights surrounding it, and the ease of accessibility to these attractions as the positive rather than the highlight being city specific.

The question intended for the polling audience to select from regions on the graphic collage that most resonated with them. Options varied from Ontario specific highlights, to landmarks nearby. The resulting responses highlighted suburbia, the mountains, Route 66, and shopping as key components. This answer supported previous answers highlighting the city as a gateway, and it's focus on it's tight knit community.

Q15 - Please rank the following activities in your area ...

Shopping/Fashion
Entertainment
 Food
 Sports

Q16/17/18 - Please rank these food scenes / Leisure activities / architecture presences in your area...



Q19 - Please select up to 3 images that resonate with you the most about Ontario CA.



Q20 - Please select up to 3 images that resonate with you the most about Ontario CA.



Q21 - Please select up to 3 images that resonate with you the most about Ontario CA.



Questions 15-21 focused on Ontario specifically, stepping into attractions and cultural aspects more specific to the city itself. In this series of questions, the polling audience was asked to rank attractions, and select images that resonated with them on a more micro level. The shopping/retail experience, and images highlighting surrounding mountains outranked those of food, entertainment, and historic significance. This information helped the design team celebrate these specific elements in the creation of the wayfinding design options.

Q22/23/24 - Which Image / Color Palette / Material Palette feels most in line with Ontario?

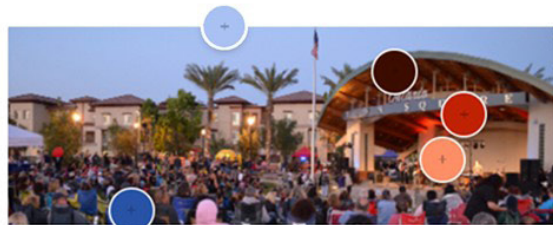

In the final series of questions (22, 23 and 24), the polling audience was given a selection of three images pulled from banner or background images for sites centered around Ontario, and asked which resonated with them. This was followed by color palettes, and then material palettes that were generated around those images, though the origin of inspiration for these next selections was not addressed with the polling audience. The design team's intent with these questions was to see if the polling audience would be aligned amongst each other as well as with a singular palette of materials, to uncover and color or material biases, and to gently influence the final signage and design output. Through the selections made by the polling audience, the design team saw the majority resonated with the blues, the earthy accents, and that they shied away from citrus pops and bright punches.

